

Model B12-71

2-Wire Hydrogen Gas Transmitter

Home Office

Analytical Technology, Inc.
6 Iron Bridge Drive
Collegeville, PA 19426

Ph: 800-959-0299
610-917-0991

Fax: 610-917-0992

Email: sales@analyticaltechnology.com

European Office

ATI (UK) Limited
Unit 1 & 2 Gatehead Business Park
Delph New Road, Delph
Saddleworth OL3 5DE

Ph: +44 (0)1457-873-318

Fax: + 44 (0) 1457-874-468

Email: sales@atiuk.com

PRODUCT WARRANTY

Analytical Technology, Inc. (Manufacturer) warrants to the Customer that if any part(s) of the Manufacturer's equipment proves to be defective in materials or workmanship within the earlier of 18 months of the date of shipment or 12 months of the date of start-up, such defective parts will be repaired or replaced free of charge. Inspection and repairs to products thought to be defective within the warranty period will be completed at the Manufacturer's facilities in Collegeville, PA. Products on which warranty repairs are required shall be shipped freight prepaid to the Manufacturer. The product(s) will be returned freight prepaid and allowed if it is determined by the manufacturer that the part(s) failed due to defective materials or workmanship.

This warranty does not cover consumable items, batteries, or wear items subject to periodic replacement including lamps and fuses.

Gas sensors carry a 12 months from date of shipment warranty and are subject to inspection for evidence of misuse, abuse, alteration, improper storage, or extended exposure to excessive gas concentrations. Should inspection indicate that sensors have failed due to any of the above, the warranty shall not apply.

The Manufacturer assumes no liability for consequential damages of any kind, and the buyer by acceptance of this equipment will assume all liability for the consequences of its use or misuse by the Customer, his employees, or others. A defect within the meaning of this warranty is any part of any piece of a Manufacturer's product which shall, when such part is capable of being renewed, repaired, or replaced, operate to condemn such piece of equipment.

This warranty is in lieu of all other warranties (including without limiting the generality of the foregoing warranties of merchantability and fitness for a particular purpose), guarantees, obligations or liabilities expressed or implied by the Manufacturer or its representatives and by statute or rule of law.

This warranty is void if the Manufacturer's product(s) has been subject to misuse or abuse, or has not been operated or stored in accordance with instructions, or if the serial number has been removed.

Analytical Technology, Inc. makes no other warranty expressed or implied except as stated above.

TABLE OF CONTENTS

TABLE OF CONTENTS	2
INTRODUCTION	3
<i>Figure 1 – Typical % Version Insertion System Installation (ATI-0156)</i>	<i>3</i>
<i>Figure 2 – Typical PPM Remote Version Insertion System Installation (ATI-0165)</i>	<i>4</i>
<i>Figure 3 – Typical PPM Standard Version Insertion System Installation (ATI-0166)</i>	<i>5</i>
<i>Figure 4 - Typical Flow Through System Installation (ATI-0223)</i>	<i>6</i>
SPECIFICATIONS	7
INSTALLATION	8
MECHANICAL MOUNTING	8
<i>Figure 5 - Nema-4X Enclosure Dim for Remote PPM & % Versions (ATI-083)</i>	<i>8</i>
<i>Figure 6 - Nema-4X Enclosure Dim for Std. PPM Versions (ATI-0198)</i>	<i>9</i>
<i>Figure 7 - Explosion-Proof Transmitter Enclosure Dimensions (ATI-0226)</i>	<i>9</i>
<i>Figure 8 - Wet Hydrogen Gas Sensor Dimensions all versions (ATI-0276)</i>	<i>10</i>
ELECTRICAL CONNECTION	11
<i>Figure 9 - Electrical Connections, Nema-4 Enclosure (ATI-0288)</i>	<i>11</i>
<i>Figure 10 - Electrical Connections, Explosion-proof Enclosure (ATI-0289)</i>	<i>12</i>
HYDROGEN SENSOR ASSEMBLY	13
<i>FIGURE 11 - % HYDROGEN GAS SENSOR ASSEMBLY (ATI-0290)</i>	<i>13</i>
OPERATION	15
TRANSMITTER TEST POINTS	15
DIGITAL DISPLAY OPTION	16
<i>Figure 12 - Transmitter Controls & Test Points (ATI-0291)</i>	<i>16</i>
CALIBRATION	17
ZERO ADJUSTMENT	17
SPAN ADJUSTMENT	17
MAINTENANCE	18
SPARE PARTS LIST	19

INTRODUCTION

The Series B12-71 is a two-wire transmitter designed to work with ATI's Model 71 Wet Hydrogen Gas Sensor. It provide a low power method of monitoring hydrogen in moisture saturated gas streams.

GAS	CODE NO.	STD. RANGE	MIN. RANGE	MAX. RANGE
HYDROGEN	71	4%	0-1%	0-10%
HYDROGEN	71	2000 PPM	0-500 PPM	0-5000 PPM

Figure 1 shows a typical B12-71 Hydrogen monitoring system for a vent or duct system.

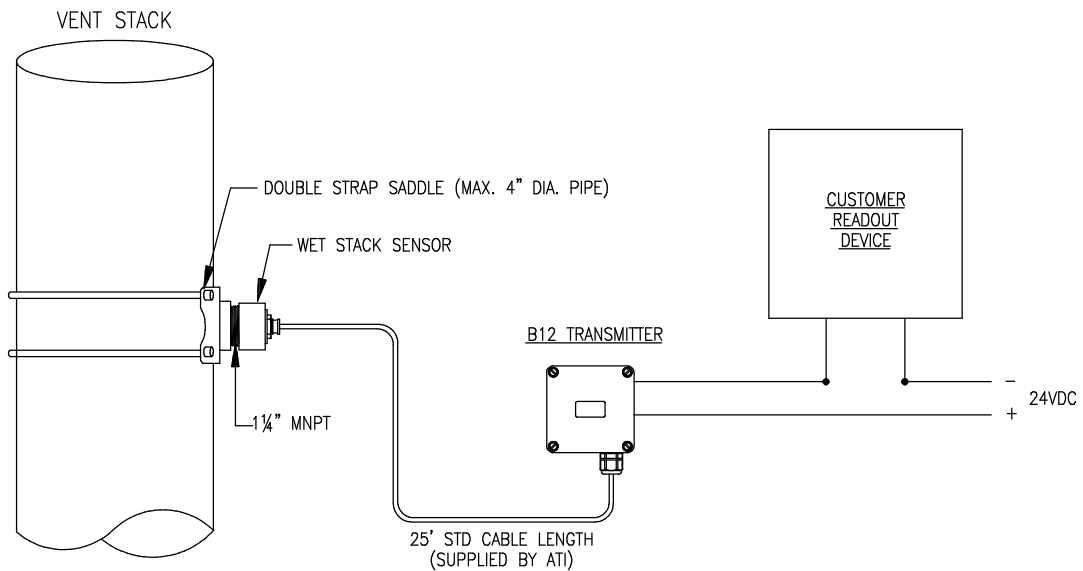

Figure 1 – Typical % Version Insertion System Installation (ATI-0156)

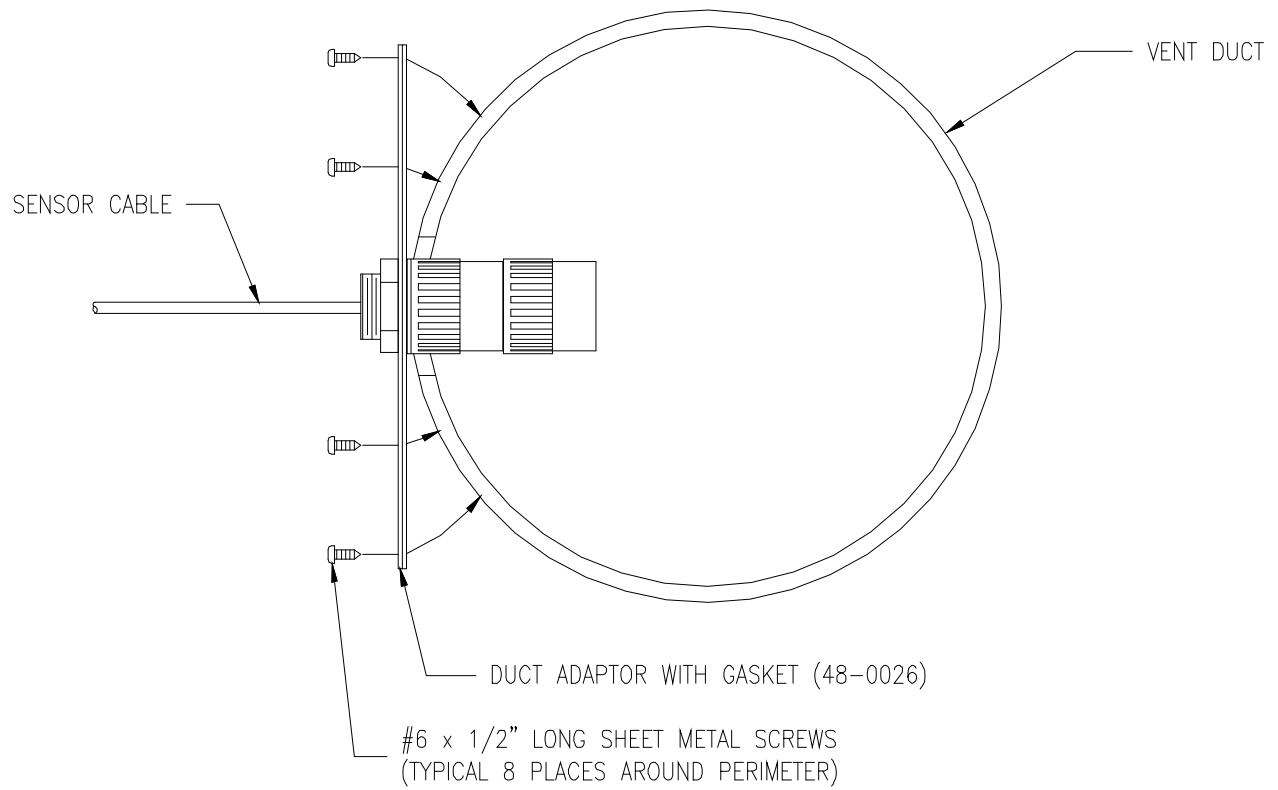

Figure 2 – Typical PPM Remote Version Insertion System Installation (ATI-0165)

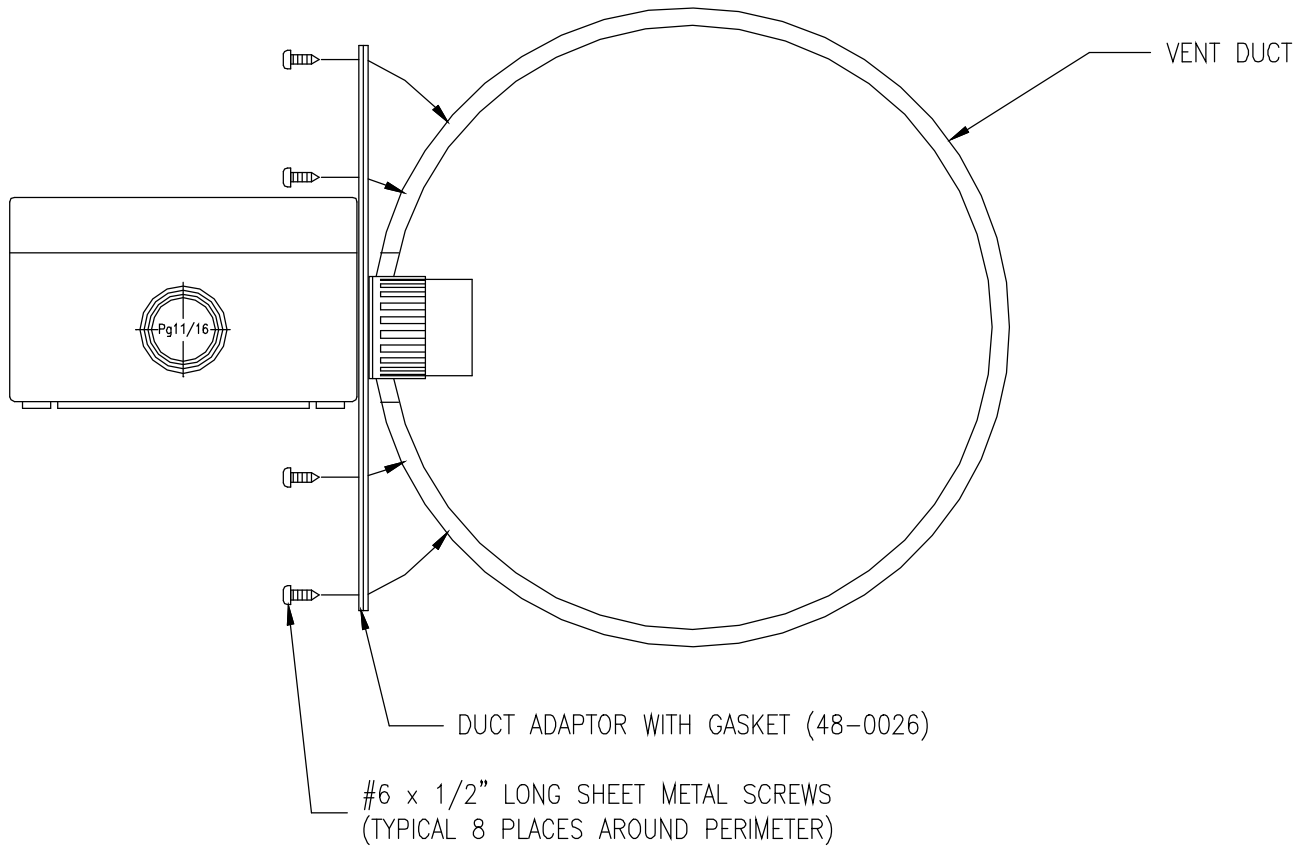

Figure 3 – Typical PPM Standard Version Insertion System Installation (ATI-0166)

Figure 4 shows a typical flow through B12-71 gas monitoring system. The sensor is shown with the flowcell in place. If used in insertion applications, the flowcell must be removed.

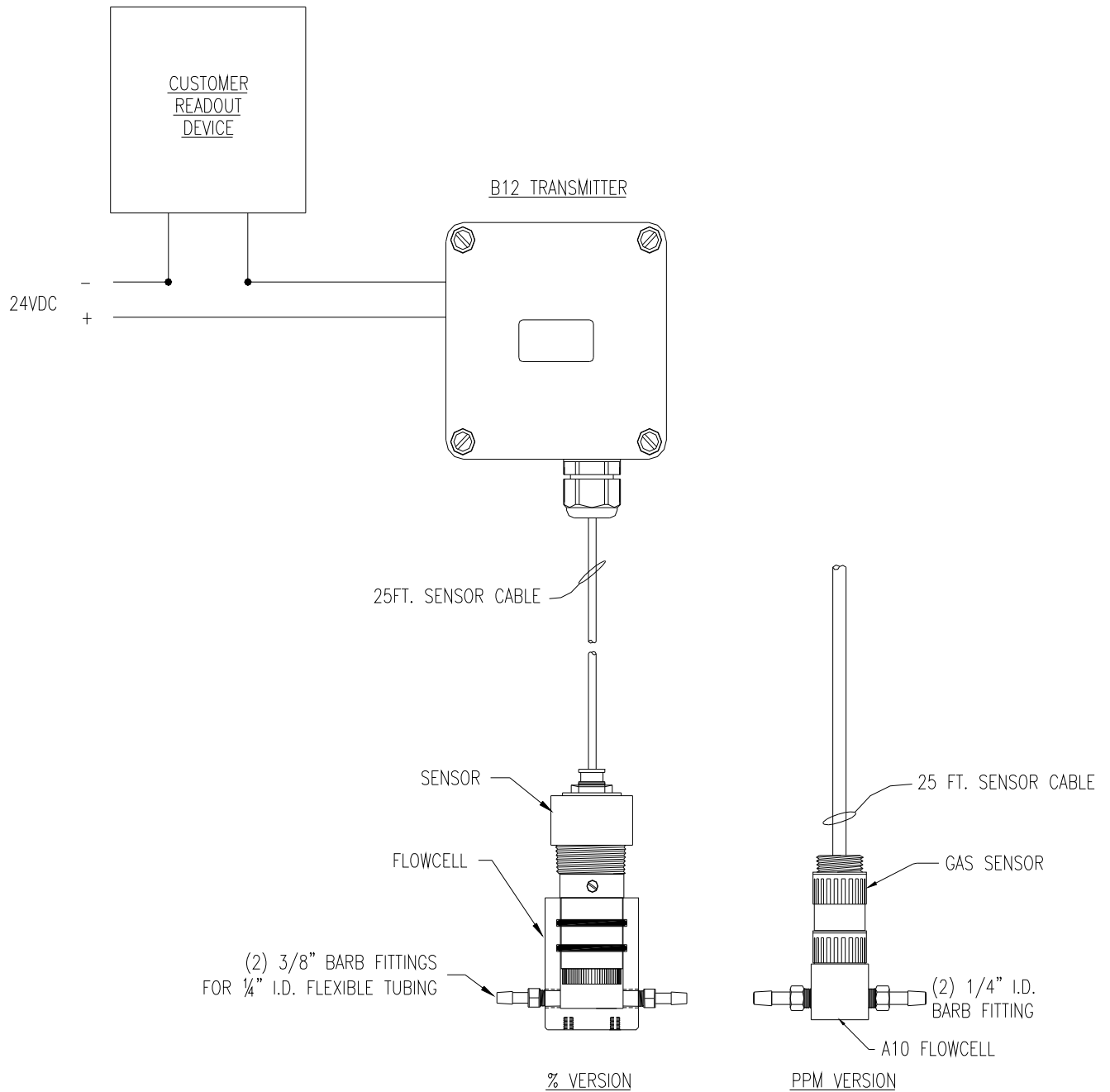

Figure 4 - Typical Flow Through System Installation (ATI-0223)



SPECIFICATIONS

Type: Wet Hydrogen Gas

Range: 0-1% Min., 0-10% Max.
0-500 PPM Min., 0-5000 PPM Max.

Accuracy: ± 0.05 % at constant temperature

Electronic Repeatability: ± 1 % of span

Electronic Linearity: ± 0.5 % of span

Output: Loop-powered 4-20 mA, 675 ohms maximum at 24 VDC

Power: 12-30 VDC

Enclosure: NEMA 4X polystyrene

Controls: Zero and span potentiometers mounted on transmitter circuit board

Operating Temperature: 0° to +55° C

Sensor: Model 71 Hydrogen Sensor

Sample Flow Requirements (When using Flowcell): 500 - 2000 cc/min.

Weight: 0.25 Lbs (0.12 Kg.)

INSTALLATION

Installation of a B12 Transmitter requires mechanically mounting the enclosure and connecting DC power to the system. In addition, the flowcell assembly for the sensor must be connected to sample inlet and outlet tubing. Hose barbs are supplied on the flowcell, and the inlet and outlet ports are suitable for a variety of fitting with 1/8" NPT connections.

MECHANICAL MOUNTING

The NEMA 4X transmitter enclosure is surface mounted using screws inserted through the blind mounting holes accessible by removing the transmitter cover. Figure 5 shows the center to center mounting hole dimensions for this enclosure. If rigid conduit is to be used for wiring the transmitter, the transmitter can be supported directly from the conduit system without the use of mounting screws. The transmitter weighs only 4 ounces, so normal conduit supports will be adequate. If conduit is to be used, be sure that the conduit is sealed at the point where it enters the transmitter. Otherwise, condensation in the conduit system can drain into the transmitter causing failure of the electronic circuit board.

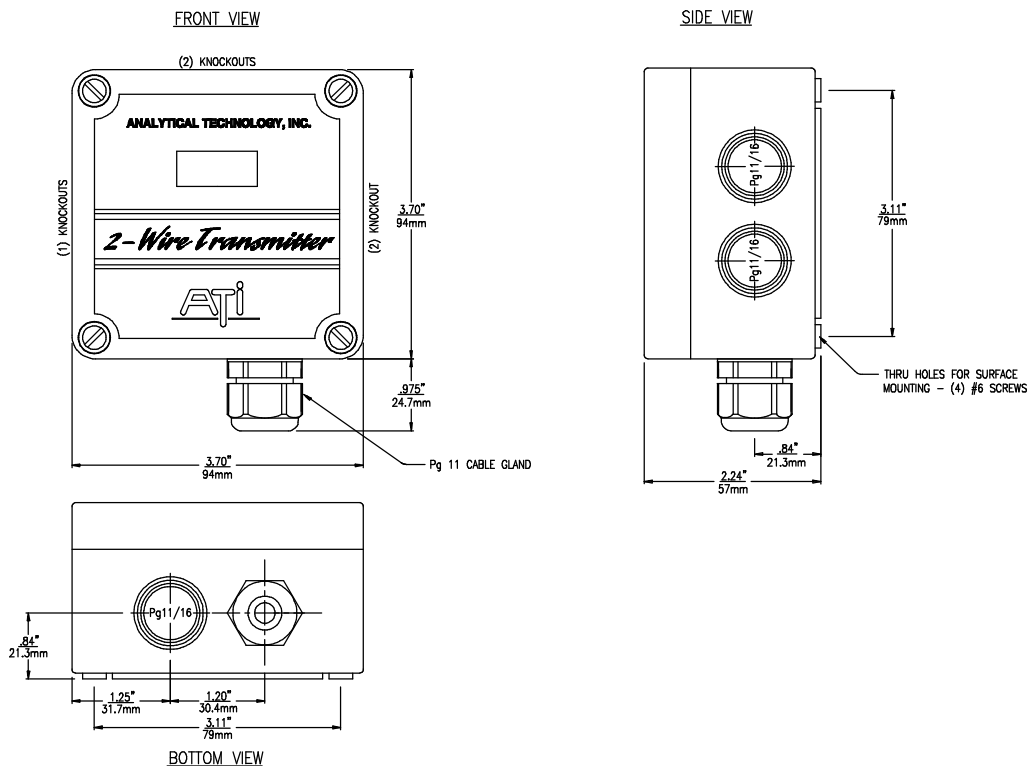

Figure 5 - Nema-4X Enclosure Dim for Remote PPM & % Versions (ATI-083)

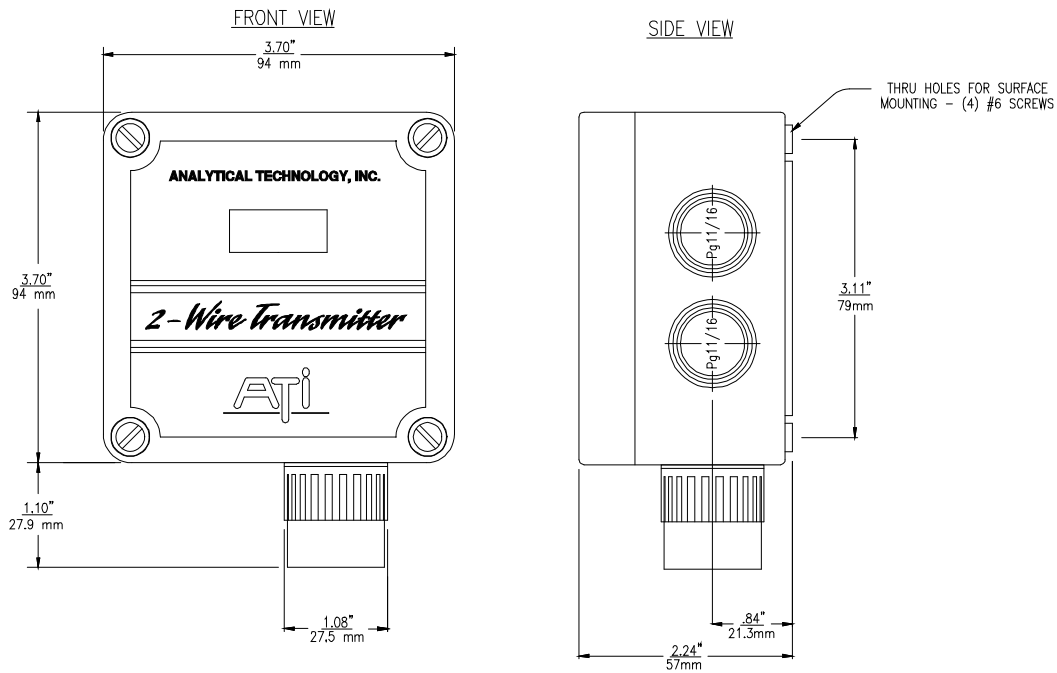

Figure 6 - Nema-4X Enclosure Dim for Std. PPM Versions (ATI-0198)

Explosion-proof transmitter enclosures should be supported by the conduit system and the installation should include proper conduit seals as required by local electrical code.

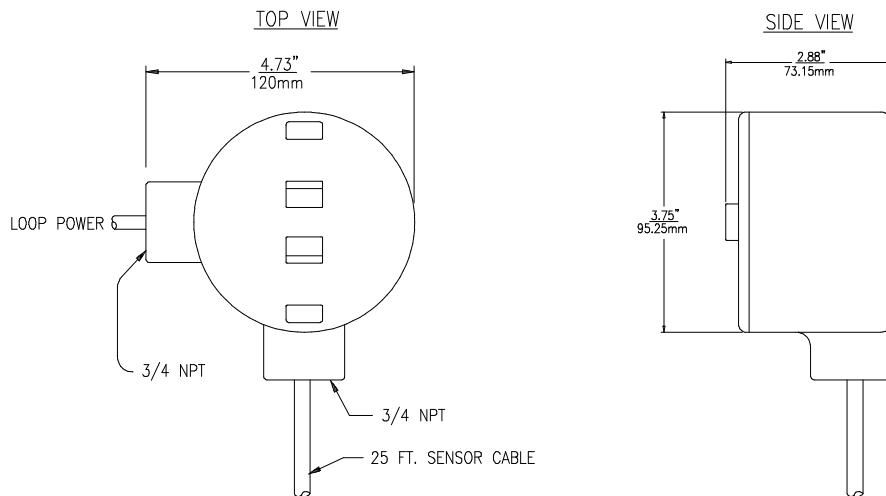

Figure 7 - Explosion-Proof Transmitter Enclosure Dimensions (ATI-0226)

The back of the insertion sensor is a 1 1/4" MNPT pipe thread. The sensor is normally threaded into a blind flange which is used to mount to the vent. The sensor should be installed perpendicular to the air flow and should be inserted far enough into the vent so that the sensor tip is at least 1/2" into the stack.

The sensor in a flow configuration is used in conjunction with the low volume flowcell (see Figure 8) to provide for sample to be delivered to the sensor using a pump or the sample pressure from the vent stack.

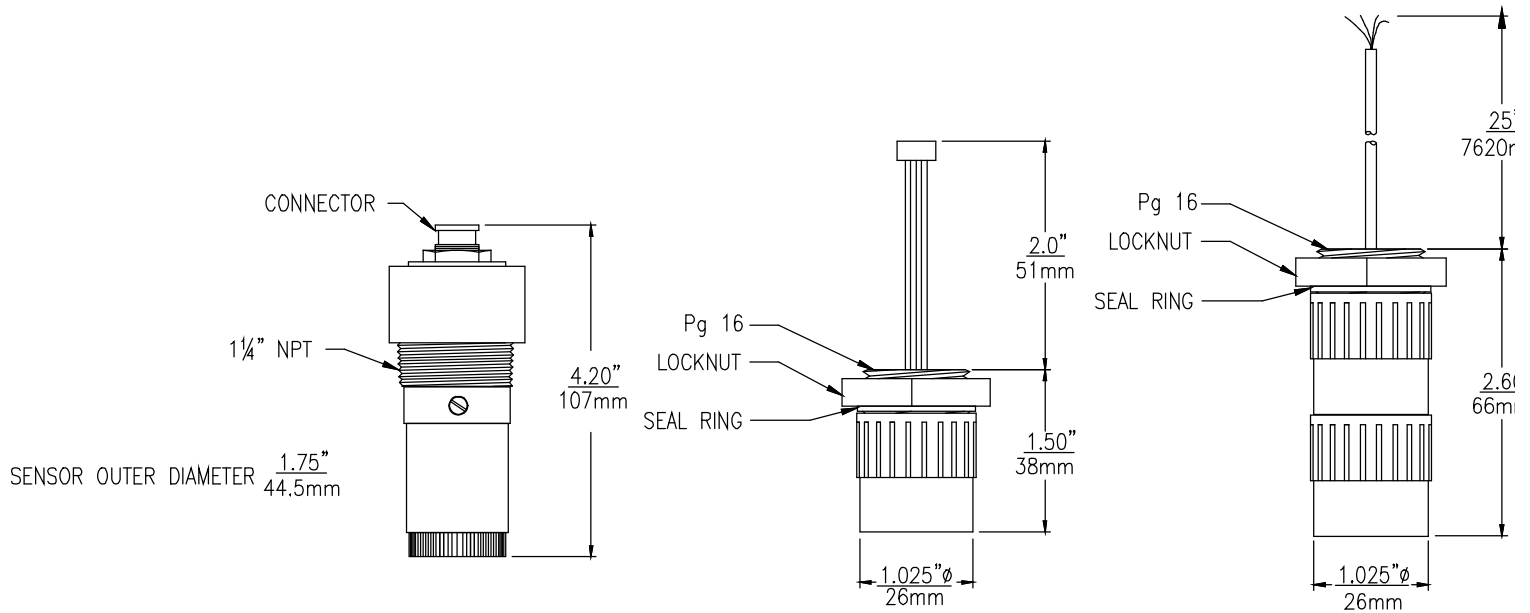

Figure 8 - Wet Hydrogen Gas Sensor Dimensions all versions (ATI-0276)

ELECTRICAL CONNECTION

B12-71 transmitters are supplied with a gland seal for the sensor wire and a 1/2" conduit hub for output loop connection. The sensor connects to a terminal block (TB2) on the transmitter circuit board. The output loop wiring is connected to TB1 as shown in Figure 9. The explosion-proof transmitter electrical connections are shown in Figure 10.

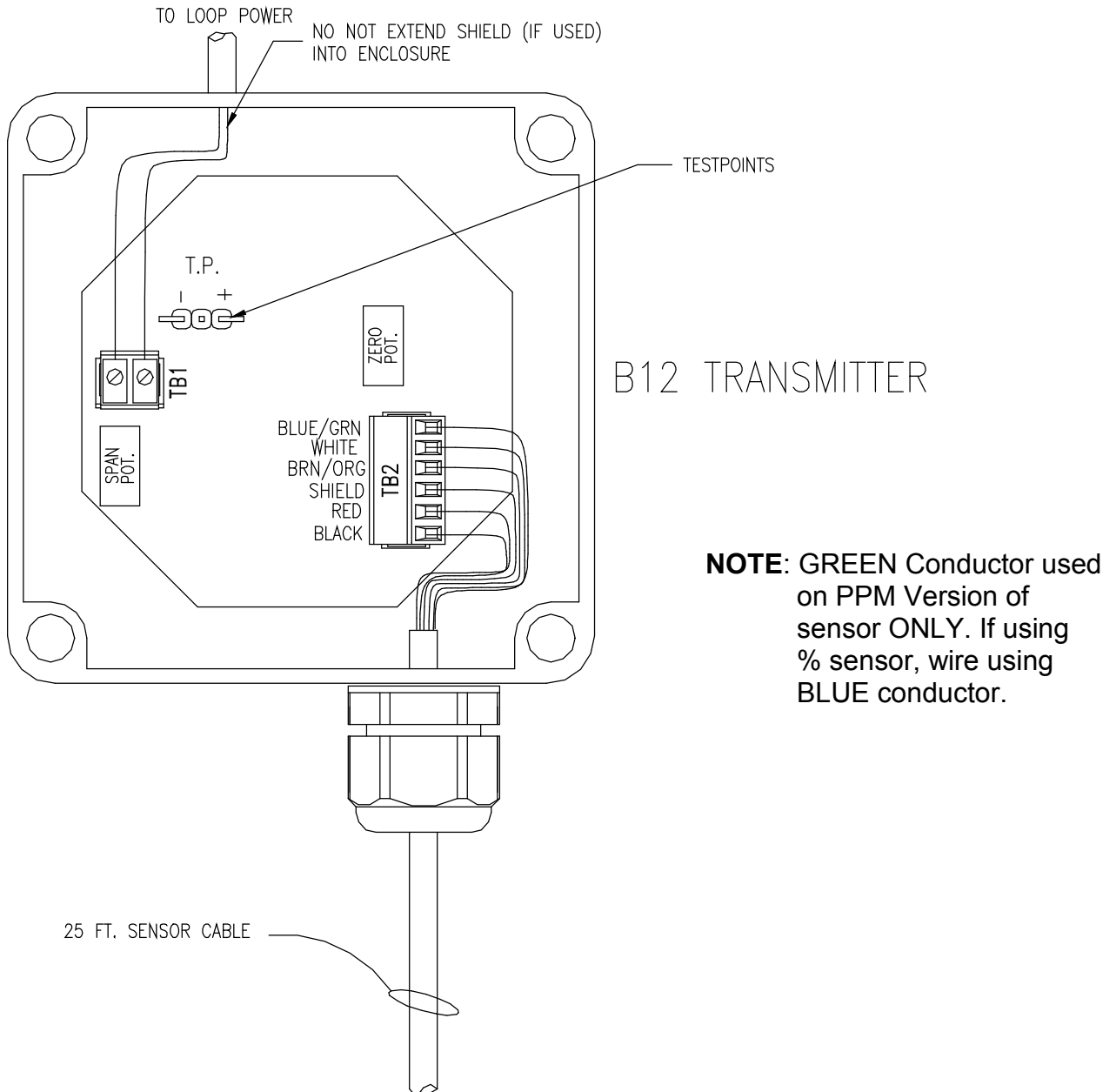

Figure 9 - Electrical Connections, Nema-4 Enclosure (ATI-0288)

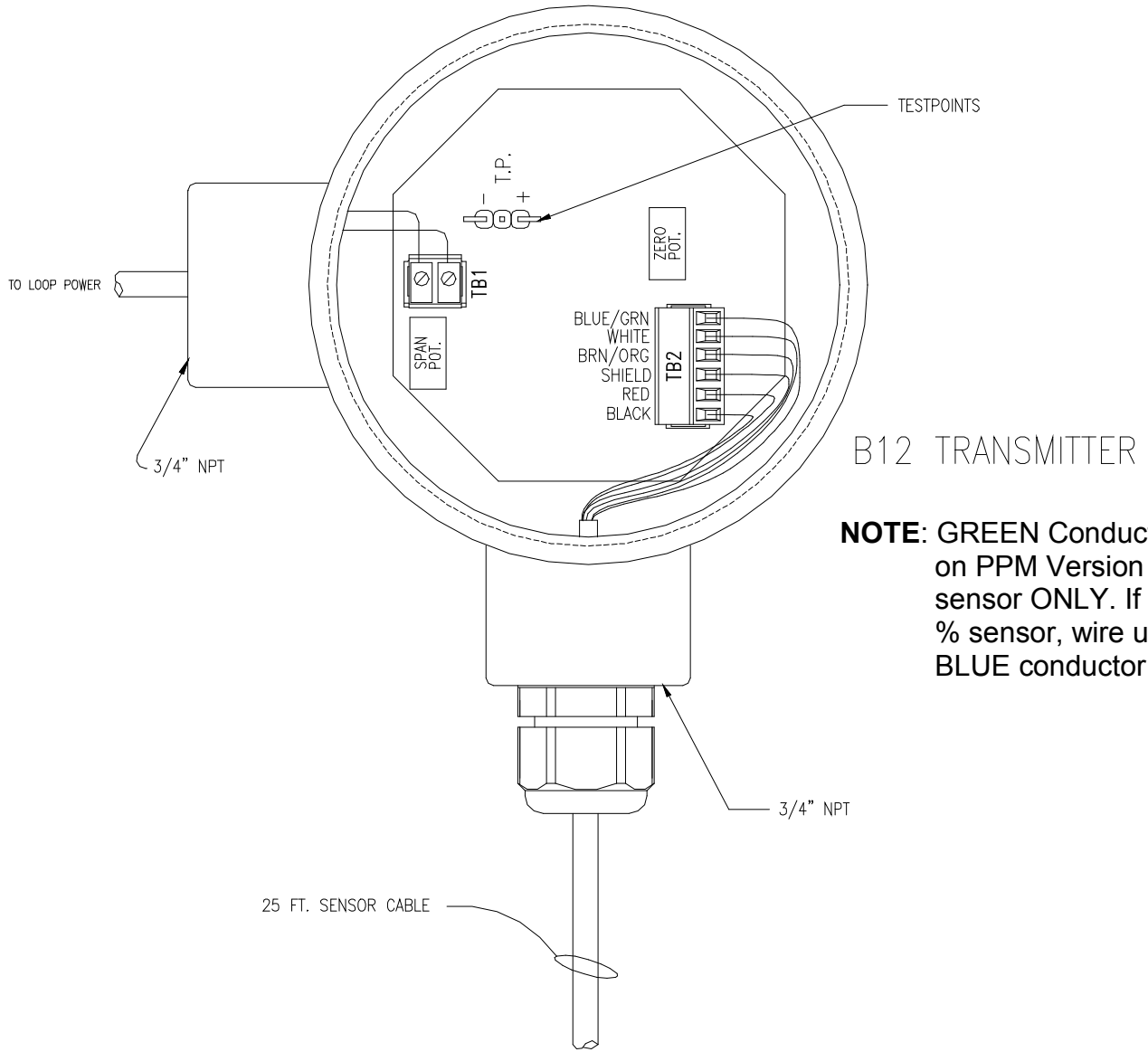

Figure 10 - Electrical Connections, Explosion-proof Enclosure (ATI-0289)

HYDROGEN SENSOR ASSEMBLY

The % hydrogen sensor supplied with the B12-71 is shipped dry. It will not operate until it is prepared by adding electrolyte and a membrane. Preparation of the sensor for operation must be done carefully. The procedure should be done by a qualified technician, and it should only be done when the system is ready for operation. Until then, it is best to leave the sensor in the condition in which it is received.

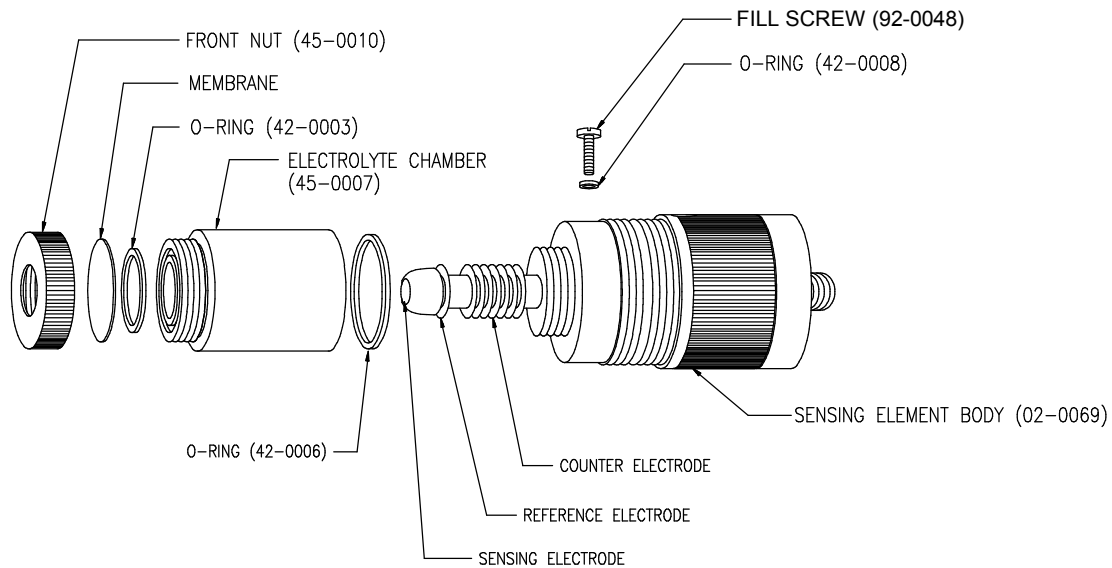

FIGURE 11 - % HYDROGEN GAS SENSOR ASSEMBLY (ATI-0290)

Follow the procedure below to prepare the hydrogen sensor for operations:

1. Unscrew the electrolyte canister from the assembled sensor and also remove the vent screw from the side of the sensor body.
2. Remove the membrane cap from the bottom of the canister and discard the protective membrane. O-rings are contained in grooves on both the bottom and top of the canister. Be sure that these o-rings remain in place.
3. From the package of membranes supplied with the sensor, place a new membrane into the membrane cap. **The membrane is clear and is separated from other membranes by a paper spacer.**
4. Screw the membrane cap on to the canister until you feel the o-ring compress. Hand tight compression is all that is needed. Do not use tools to tighten. The membrane should be flat across the bottom of the canister without wrinkles.
5. Fill the canister with electrolyte until the level reaches the bottom of the internal threads.

CAUTION: The electrolyte used in the hydrogen sensor is very acidic. Avoid skin contact or any contact with eyes. If contact occurs, flush with large amounts of water.

6. Slowly screw the canister onto the sensor body. A small amount of electrolyte will run out of the hole from which the vent screw was removed. Place a paper towel around the sensor to absorb the electrolyte overflow. Tighten the canister until the o-ring at the top of the canister is compressed. Once again, do not use tools to tighten.
7. Shake excess electrolyte from the vent hole on the side of the sensor and replace the vent screw.

The sensor is now ready for operation. The membrane should be stretched tightly across the tip of the sensor. **When handling the assembled sensor, do not set the sensor on its tip or damage to the membrane will result. Severe impacts on the tip of the sensor from dropping or other misuse may cause permanent damage to the sensor.**

PPM H2 Sensor

The PPM Wet Hydrogen sensor is a sealed, maintenance free electromechanical cell. It has a 2 year life expectancy and is replaceable.



OPERATION

After mechanical and electrical installation is complete, the system is ready for operation. Prior to start-up, recheck the loop wiring and sensor connections to be sure everything is correct. Reversing the loop wiring will not damage the transmitter, but other devices in the loop may be adversely affected.

As soon as DC loop power is applied, the transmitter will begin to operate, transmitting a 4-20 mA signal proportional to gas concentration. When first energized, the sensor will spike to a high value and then slowly begin to recover toward zero. This is normal and the system must be allowed to stabilize for at least a few hours before making any adjustments. The sensor must be connected to the transmitter and the transmitter must be powered for the sensor to stabilize.

TRANSMITTER TEST POINTS

In order to read the transmitter output locally, a digital volt (DVM) meter is recommended for transmitters without displays. The transmitter circuit board contains test points marked TP1 (see Figure 12) that allow an operator to read the 4-20 mA output without breaking the loop wiring. The test points are across a precision 10 ohm resistor that is part of the current output circuit. Therefore, any changes at the test point are a direct indication of changes in the output signal. The test point voltage will be 40 - 200 mv. proportional to 4-20 mA. This test point is used for zero and calibration functions.

DIGITAL DISPLAY OPTION

Series B12 transmitters supplied with the optional LCD have the display mounted to the enclosure cover with a clear lens protecting the display from dirt and moisture. The display is connected to the cover with a short ribbon cable soldered to the transmitter circuit board. The digital display is factory scaled to the transmitter range specified on the order.

The LCD indicates gas concentration directly in PPM or % depending on the range. It is directly in the 4-20 mA output circuit so that it is a very accurate indicator of the signal being transmitted to remote equipment. The display should be used for zeroing and calibration instead of the test points described in the calibration section of this manual.

When removing the cover of a transmitter with the LCD, be careful not to pull on the display interconnect cable. When you remove the cover, it can be temporarily fastened to the enclosure base as shown in Figure 9.

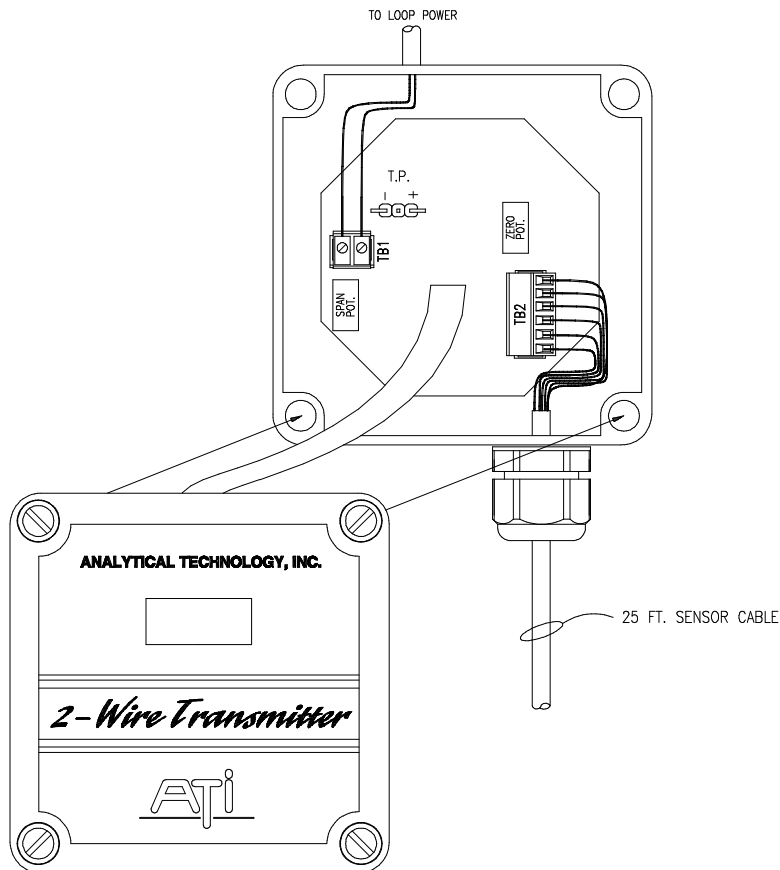

Figure 12 - Transmitter Controls & Test Points (ATI-0291)

CALIBRATION

Transmitter calibration requires adjustment of both zero and span. Zero is adjusted when the sensor is exposed to a gas stream containing no hydrogen. Adjusting the span requires that the sensor be placed in a gas stream containing a known hydrogen concentration.

ZERO ADJUSTMENT

As previously mentioned, adjusting the sensing module zero requires that the sensor be exposed to a gas stream that does not contain hydrogen. If the sensor has just been rebuilt or if the system is being started up for the first time, leave the sensor in the ambient air for at least 3-4 hours to come to a stable zero. If the system has been in operation, 10 minutes is sufficient to get a good zero. Do not allow the sensor to operate in dry gas streams for extended periods of time or the sensitivity will decrease.

To zero the transmitter, remove the cover and connect a DVM to the test points shown in Figure 6. Observe the DVM value to be sure that it is no longer declining, and that it is stable ± 4 mv. Use the zero potentiometer to adjust the test point voltage to 0.040 VDC (40 mv.). If the transmitter is supplied with the LCD display, simply adjust the potentiometer until the display reads 0.0.

SPAN ADJUSTMENT

Once the zero has been set, insert the sensor into the flowcell and turn on the gas flow containing a known hydrogen concentration. The recommended gas flowrate is between 200 and 1000 cc/min. Allow the gas sample to flow for at least 5 minutes.

Observe the DVM value. The reading should be relatively stable ± 4 mv. Adjust the span potentiometer (Figure 6) until the proper test point voltage is obtained. The proper voltage to set when adjusting transmitter span will vary depending on the range of the transmitter. The following formula is used to calculate the proper span voltage for any transmitter. If the transmitter contains an LCD display, simply adjust the span potentiometer until the display indicates the span gas concentration.

$$V = 0.040 V + 0.160 X \text{ (Measured Concentration } \div \text{ Transmitter Range)}$$

As an example, suppose you are calibrating a transmitter with a range of 0-2% . The know gas sample contains 1.5% hydrogen. The above formula would then become:

$$V = 0.040 V + 0.160 X (1.5 \div 2) = 0.160 V.$$

Therefore, adjusting the transmitter to a reading of 160 mv. at the test point would properly calibrate the transmitter.

MAINTENANCE

The only maintenance required on the B12-71 system is periodic sensor service. The % hydrogen sensor uses a membrane that can lose sensitivity with the accumulation of solids or precipitates in the membrane. As a preventive measure, sensors should be rebuilt with new membrane and electrolyte about every 2-3 months. The electrolyte in the sensor should always be changed when the membrane is changed. The PPM hydrogen sensor is maintenance free and simply requires replacement.



SPARE PARTS LIST

<u>PART NO.</u>	<u>DESCRIPTION</u>
01-0067	B12-71 transmitter PCB (% Version)
01-0193	B12-71 Standard Transmitter PCB (PPM Version)
01-0194	B12-71 Remote Transmitter PCB (PPM Version)
81-0002	NEMA 4X enclosure (top and bottom)
03-0039	Explosion-proof Enclosure Assembly
38-0002	Terminal block plug, 2 position
92-0005	Self-tapping screws, (pkg. of 4), (for NEMA 4 enclosure)
92-0007	Self-tapping screws, (pkg. of 4), (for Explosion-proof enclosure)
44-0017	Pg 16 to 1/2" NPT conduit hub with nut
44-0018	Seal ring (required for NEMA 4X rating on conduit hubs)
00-0781	% Wet Hydrogen gas sensor
00-1345	A10-71 Wet standard sensor (PPM version)
00-1346	A10-71 Wet remote sensor (PPM version)
02-0069	Sensing element body (for #00-0781)
03-0029	Sensor interconnect cable, 25 ft. (% version only)
31-0001	25ft. 5 cond. shielded cable (PPM version)
00-0422	Flowcell Assembly (% version)
00-0255	Flowcell Assembly (PPM version)
45-0007	Electrolyte chamber
45-0010	Front Nut, noryl
05-0025*	Membranes, pkg. of 10
05-0028*	Spare Parts Kit, screw & o-ring
09-0022*	Hydrogen sensor electrolyte, 4 oz (120 cc)

Note: Instrument is supplied with sufficient spare part for 6-12 months of operation. For 2 year spare parts inventory, 2 each of the items marked with an asterisk (*) should be ordered.