

Model Q46C4

4-Electrode Conductivity Monitor

Home Office

Analytical Technology, Inc.
6 Iron Bridge Drive
Collegeville, PA 19426

Ph: 800-959-0299
610-917-0991
Fax: 610-917-0992
Email: sales@analyticaltechnology.com

European Office

ATI (UK) Limited
Unit 1 & 2 Gatehead Business Park
Delph New Road, Delph
Saddleworth OL3 5DE

Ph: +44 (0)1457-873-318
Fax: + 44 (0)1457-874-468
Email: sales@atiuk.com

PRODUCT WARRANTY

Analytical Technology, Inc. (Manufacturer) warrants to the Customer that if any part(s) of the Manufacturer's equipment proves to be defective in materials or workmanship within the earlier of 18 months of the date of shipment or 12 months of the date of start-up, such defective parts will be repaired or replaced free of charge. Inspection and repairs to products thought to be defective within the warranty period will be completed at the Manufacturer's facilities in Collegeville, PA. Products on which warranty repairs are required shall be shipped freight prepaid to the Manufacturer. The product(s) will be returned freight prepaid and allowed if it is determined by the manufacturer that the part(s) failed due to defective materials or workmanship.

This warranty does not cover consumable items, batteries, or wear items subject to periodic replacement including lamps and fuses.

Gas sensors carry a 12 months from date of shipment warranty and are subject to inspection for evidence of misuse, abuse, alteration, improper storage, or extended exposure to excessive gas concentrations. Should inspection indicate that sensors have failed due to any of the above, the warranty shall not apply.

The Manufacturer assumes no liability for consequential damages of any kind, and the buyer by acceptance of this equipment will assume all liability for the consequences of its use or misuse by the Customer, his employees, or others. A defect within the meaning of this warranty is any part of any piece of a Manufacturer's product which shall, when such part is capable of being renewed, repaired, or replaced, operate to condemn such piece of equipment.

This warranty is in lieu of all other warranties (including without limiting the generality of the foregoing warranties of merchantability and fitness for a particular purpose), guarantees, obligations or liabilities expressed or implied by the Manufacturer or its representatives and by statute or rule of law.

This warranty is void if the Manufacturer's product(s) has been subject to misuse or abuse, or has not been operated or stored in accordance with instructions, or if the serial number has been removed.

Analytical Technology, Inc. makes no other warranty expressed or implied except as stated above.

Table of Contents

PART 1 - INTRODUCTION	4	PART 6 – CALIBRATION	55
1.1 General.....	4	6.1 Overview and Methods.....	55
1.2 Features	5	6.11 1-Point Cal Explained	55
1.3 Q46C4 System Specifications.....	6	6.12 Zero Cal Explained	56
1.4 Q46C4 Performance Specifications	8	6.2 Performing Sensor Zero Cal	56
PART 2 – ANALYZER MOUNTING	9	6.3 Performing 1-Point Cal	56
2.1 General.....	9	6.4 Temperature Calibration.....	59
2.2 Wall or Pipe Mount	10	PART 7 – PID CONTROLLER DETAILS	60
2.3 Panel Mount Monitor.....	12	7.1 PID Description	60
PART 3 – SENSOR/FLOWCELL MOUNTING	13	7.2 PID Algorithm	60
3.1 General.....	13	7.3 Classical PID Tuning	63
3.2 Sealed Flowcell	15	7.4 Manual PID Override Control.....	63
3.3 Flow Tee Mounting	16	7.5 Common PID Pitfalls	64
3.4 Union Mounting	17	PART 8 – SYSTEM MAINTENANCE	65
3.5 Submersion Mounting.....	19	8.1 System Checks	65
3.6 Insertion Mounting	20	8.2 Instrument Checks.....	65
PART 4 – ELECTRICAL INSTALLATION ...	22	8.3 Cleaning the Sensor	66
4.1 General.....	22	8.4 Troubleshooting.....	67
4.2 Power Connection	23	8.5 Display Messages	68
4.3 Relay Connection	25	SPARE PARTS.....	71
4.4 Optional Output or Relay Connections.....	26		
4.5 Sensor Wiring.....	27		
4.6 Direct Sensor Connection	30		
4.7 Junction Box Connection	31		
PART 5 – CONFIGURATION	32		
5.1 User Interface.....	32		
5.11 Keys	33		
5.12 Display.....	33		
5.2 Software	35		
5.22 Measure Menu [MEASURE]	38		
5.23 Calibration Menu [CAL].....	39		
5.24 Configuration Menu [CONFIG].	40		
5.25 Control Menu	45		
5.26 Diagnostics Menu [DIAG].....	50		

Table of Figures

<i>FIGURE 1 - Q46 ENCLOSURE DIMENSIONS</i>	9
<i>FIGURE 2 - WALL OR PIPE MOUNT BRACKET</i>	10
<i>FIGURE 3 - WALL MOUNTING DIAGRAM</i>	11
<i>FIGURE 4 - PIPE MOUNTING DIAGRAM</i>	11
<i>FIGURE 5 - AC PWR PANEL MOUNT CUTOUT</i>	12
<i>FIGURE 6 - Q25C4 SENSOR DIMENSIONS</i>	14
<i>FIGURE 7 - SEALED FLOWCELL DETAILS</i>	15
<i>FIGURE 8 - FLOW THROUGH TEE MOUNT</i>	16
<i>FIGURE 9 - 1.5" UNION MOUNT</i>	17
<i>FIGURE 10 - 2" UNION MOUNT</i>	18
<i>FIGURE 11 - SENSOR SUBMERSION MOUNT</i>	19
<i>FIGURE 12 - S.S. SENSOR INSERTION MOUNT</i>	20
<i>FIGURE 13 - CPVC SENSOR INSERTION MOUNT</i>	21
<i>FIGURE 14 - Q46 CONNECTION LAYOUT</i>	24
<i>FIGURE 15 - RELAY CONNECTIONS</i>	25
<i>FIGURE 16 - OPTIONAL RELAY BOARD WIRING</i>	26
<i>FIGURE 17 - OPTIONAL ANALOG OUTPUT WIRING</i>	26
<i>FIGURE 18 - STANDARD DOUBLE SHIELDED CABLE</i>	27
<i>FIGURE 19 - DETACHABLE SINGLE SHIELDED CABLE</i>	28
<i>FIGURE 20 - Q46C4 SENSOR CONNECTIONS</i>	29
<i>FIGURE 21 - SENSOR CABLE PREPARATION</i>	30
<i>FIGURE 22 - JUNCTION BOX INTERCONNECT WIRING</i>	31
<i>FIGURE 23 - USER INTERFACE</i>	32
<i>FIGURE 24 - SOFTWARE MAP</i>	37
<i>FIGURE 25 - CONTROL RELAY EXAMPLE</i>	48
<i>FIGURE 26 - ALARM RELAY EXAMPLE</i>	49
<i>FIGURE 27 - NA₂CO₃ REFERENCE SOLUTION CALIBRATION CHART</i>	57
<i>FIGURE 28 - PID EQUATION</i>	61

Part 1 - Introduction

1.1 General

The Model Q46C4 Conductivity monitor/analyzer provides a versatile system for monitoring and control of conductivity over a range of 1 $\mu\text{S}/\text{cm}$ to 2.000 Siemens/cm. The display may be programmed for ranges of 0-2000 μS , 0-2.000 mS, 0-20.00 mS, 0-200 mS, 0-2000 mS, or 0-2.000 S. A lower line display indicates the equivalent TDS value in mg/l, using a user programmable conversion factor.

Monitors are available in two electronic versions, a universal AC powered monitor for operation from 90-260 VAC and a 12-24 VDC unit. Both versions provide two 4-20 mA analog outputs and 3 SPDT relays. One analog output may be configured for PID control and one of the relays may be configured to provide a remote trouble indication.

The Q46C4 is available with a few options to expand the capabilities of the monitor. Users may select either a third analog 4-20 mA output or an expansion card that provides three additional low voltage SPST relays. The expansion relays are not isolated from each other.

This monitor also provides digital communication capability. Users may order Q46 systems with either Profibus DP, Modbus RTU, or Ethernet communications boards factory installed.



WARNING: Not following operating instructions may impair safety.

1.2 Features

- Power options for either AC or low voltage DC operation.
- High accuracy, high sensitivity system, measures from 1 to 2,000,000 uS through 7 internal automatic ranges. User display ranges include 2000 us, 2.000 mS, 20.00 mS, or 200.0 mS, 2000 mS, or 2.000 S.
- Output Hold, Output Simulate, Output Alarm, and Output Delay. All forced changes in output condition include bumpless transfer to provide gradual return to on-line signal levels and to avoid system control shocks on both analog outputs.
- Selectable PID controller on main analog output. PID includes manual operation feature, and diagnostic “stuck-controller” timer feature for relay notification of control problems.
- Digital communication option for Profibus-DP, Modbus-RTU. More versions pending. See Q46 Digital Communications Manual for Specifications.
- Configurable for TDS display and signal output on one analog output.
- Two analog outputs track conductivity and temperature, conductivity and conductivity, or conductivity and TDS. Both analog outputs can be individually programmed to fail to specific values.
- Large, high contrast, custom LCD display with LED back light provides excellent readability in any light conditions. The second line of display utilizes 5x7 dot matrix characters for clear message display.
- 4-Electrode measurement system. Two of the electrodes establish the sensor drive potential, while the other two sense the flow of current between the drive electrodes and maintain proper drive potential. Sensor diagnostics monitor electrode coating/fouling, sensor leaks, and RTD condition. Diagnostic messages provide a clear description of any problem with no confusing error codes. Messages are also included for diagnosing calibration problems.
- Quick and easy one-point calibration method and sensor zero-cal. To provide high accuracy, all calibration methods include stability monitors that check temperature and main parameter stability before accepting data.
- High accuracy Pt1000 temperature input. Temperature element can be user calibrated.
- Security lock feature to prevent unauthorized tampering with transmitter settings.

All settings can be viewed while locked, but they cannot be changed.

1.3 Q46C4 System Specifications

Displayed Parameters	Main input, 0 uS to 2S (2,000,000 uS) Sensor temperature, -10.0 to 210.0 °C (23 to 410 °F) Loop current, 4.00 to 20.00 mA Sensor slope Model number and software version PID Controller Status Timer Status
Main Parameter Ranges	Automatic or Manual selection of display range 0 to 2000 uS 0.0 to 2.000 mS 0.00 to 20.00 mS 0.0 to 200.0 mS 0 to 2000 mS 0.000 to 2.000 S
Display	0.75" (19.1 mm) high 4-digit main display with sign 12-digit secondary display, 0.3" (7.6 mm) 5x7 dot matrix. Integral LED back-light for visibility in the dark.
Power	90 - 260 VAC, 50-60 Hz, 10 VA max 12-24 VDC, 500 mA max.
Enclosure	NEMA 4X, polycarbonate, stainless steel hardware, weatherproof and corrosion resistant.
Mounting Options	Wall or pipe mount bracket standard. Bracket suitable for either 1.5" or 2" I.D. U-Bolts for pipe mounting. Panel mount adapter optional.
Conduit Openings	Five ½" NPT openings, Adapter can be removed to provide a 1" NPT opening in the bottom of the enclosure. Gland seals provided but not installed.
Relays, Electromechanical:	Three SPDT, 6 amp @ 250 VAC, 5 amp @ 24 VDC contacts. Software selection for setpoint, phase, delay, deadband, hi-lo alarm, and failsafe. A-B indicators on main LCD, and C indicator on lower display.
Analog Outputs	Two 4-20 mA outputs. Output one programmable for pH or PID. Output 2 programmable for pH or Temperature. Max load 500 Ohms for each output. Outputs ground isolated and isolated from each other. An additional 3 rd analog

Keypad	option is available. 4-key membrane type with tactile feedback, polycarbonate with UV coating
Weight	2 lb. (0.9 kg)
Ambient Temperature	Analyzer Service, -20 to 60 °C (-4 to 140 °F) Storage, -30 to 70 °C (-22 to 158 °F)
Ambient Humidity	0 to 95%, indoor/outdoor use, non-condensing.
Altitude	Up to 2000 m (6562 Ft.)
Electrical Certification	Ordinary Location, cCSAus (CSA and UL standards - both approved by CSA), pollution degree 2, installation category 2
EMI/RFI Influence	Designed to EN 61326-1
Output Isolation	600 V galvanic isolation

Q25C4 Conductivity sensor

Sensor	Fully isolated 4-electrode electrode sensor design for direct measurement. 1" NPT process connection.
Measuring Range	0.000 to 2.000 S/cm
Temperature Element	Pt1000 RTD with automatic compensation
Wetted Materials	Titanium, PEEK, Viton, EPR (316SS when sensor is submersion mounted)
Temperature Compensation	Pt1000 RTD
Sensor Cable	6 Conductor plus 2 shields,
Temperature Pressure Range	The choice of sensor material/ mounting option and the hardware used to mount the sensor will determine the temperature and pressure ratings. Please consult the factory for relevant temperature and pressure rating information.
Maximum Flow Rate	10 feet (3 meters) per second
Max. Sensor-Analyzer Distance	60 feet (18.2 meters)

1.4 Q46C4 Performance Specifications

(Common to all variations)

Accuracy	0.5% of user range, or better ($\pm 2 \mu\text{S}$)
Repeatability	0.2% of user range, or better ($\pm 2 \mu\text{S}$)
Sensitivity	0.05% of user ranges ($\pm 2 \mu\text{S}$)
Stability	0.2% of user range per 24 hours, non-cumulative
Warm-up Time	3 seconds to rated performance (electronics only)
Supply Voltage Effects	$\pm 0.05\%$ of user range
Instrument Response Time	6 seconds to 90% of step input at lowest setting
Temperature Drift	Span or zero, 0.04% of span/ $^{\circ}\text{C}$



Equipment bearing this marking may not be discarded by traditional methods in the European community after August 12 2005 per EU Directive 2002/96/EC. End users must return old equipment to the manufacturer for proper disposal.

Part 2 – Analyzer Mounting

2.1 General

All Q46 Series instruments offer maximum mounting flexibility. A bracket is included with each unit that allows mounting to walls or pipes. In all cases, choose a location that is readily accessible for calibrations. Also consider that it may be necessary to utilize a location where solutions can be used during the calibration process. To take full advantage of the high contrast display, mount the instrument in a location where the display can be viewed from various angles and long distances.

Locate the instrument in close proximity to the point of sensor installation - this will allow easy access during calibration. The standard cable length of the conductivity sensor is 20 feet. For sensor cables longer than 20 feet, use the optional junction box (07-0100) and sensor interconnect cable (31-0057).

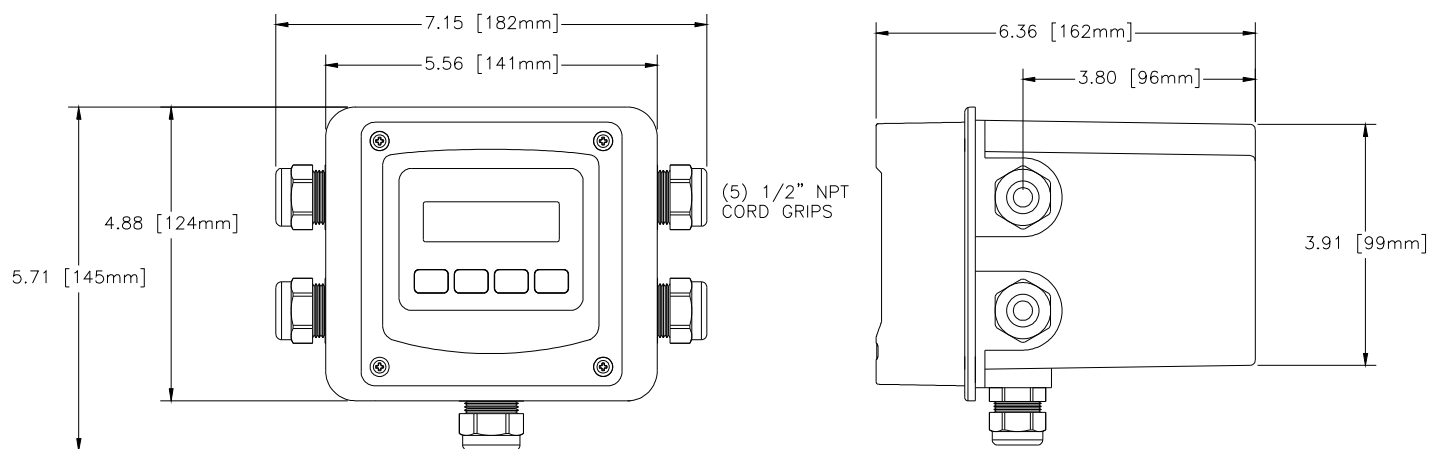

Figure 1 - Q46 Enclosure Dimensions

2.2 Wall or Pipe Mount

A PVC mounting bracket with attachment screws is supplied with each transmitter. The multi-purpose bracket is attached to the rear of the enclosure using the four flat head screws. The instrument is then attached to the wall using the four outer mounting holes in the bracket. These holes are slotted to accommodate two sizes of u-bolt that may be used to pipe mount the unit. Slots will accommodate u-bolts designed for 1½" or 2" pipe. The actual center to center dimensions for the u-bolts are shown in the drawing. Note that these slots are for u-bolts with ¼-20 threads. The 1½" pipe u-bolt (2" I.D. clearance) is available from ATI in type 304 stainless steel under part number (47-0005)

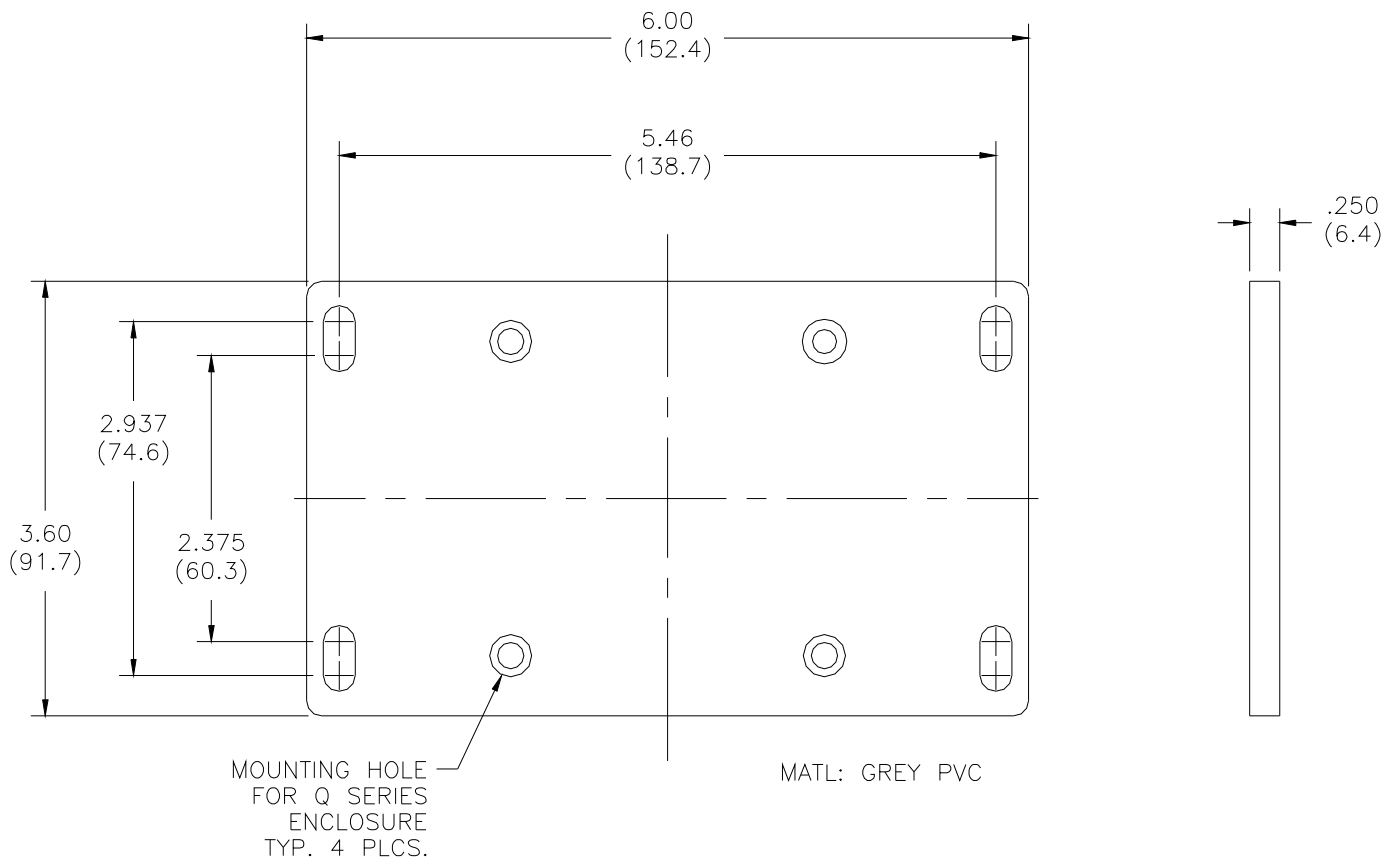

Figure 2 - Wall or Pipe Mount Bracket

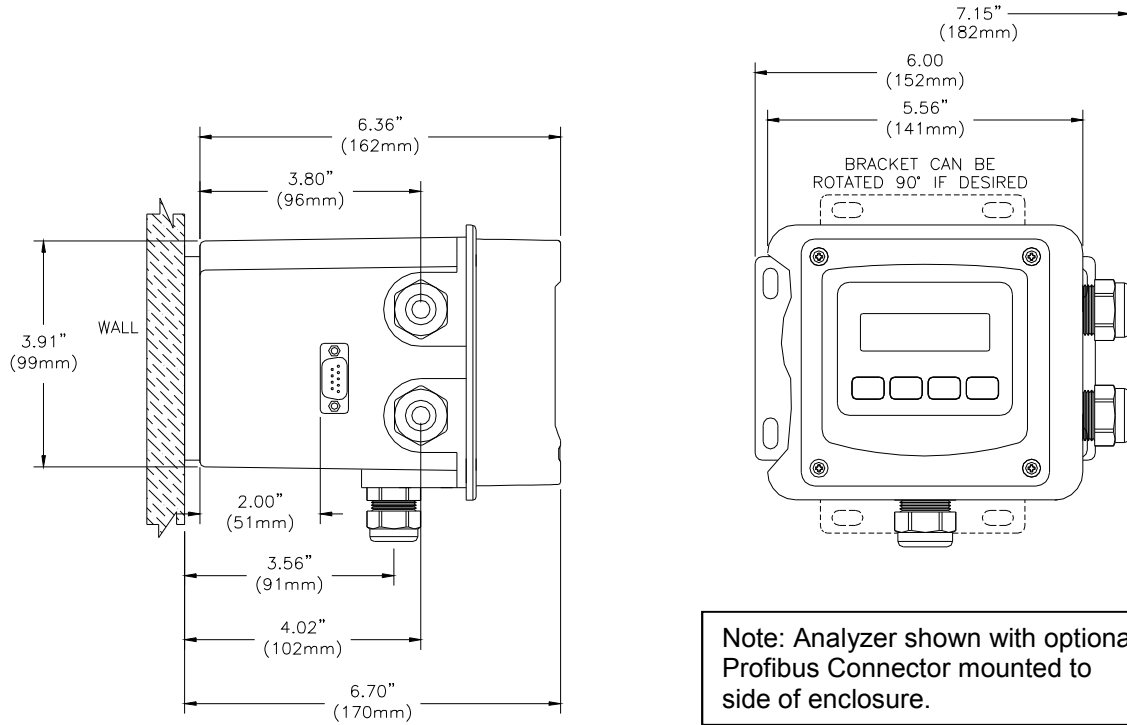

Figure 3 - Wall Mounting Diagram

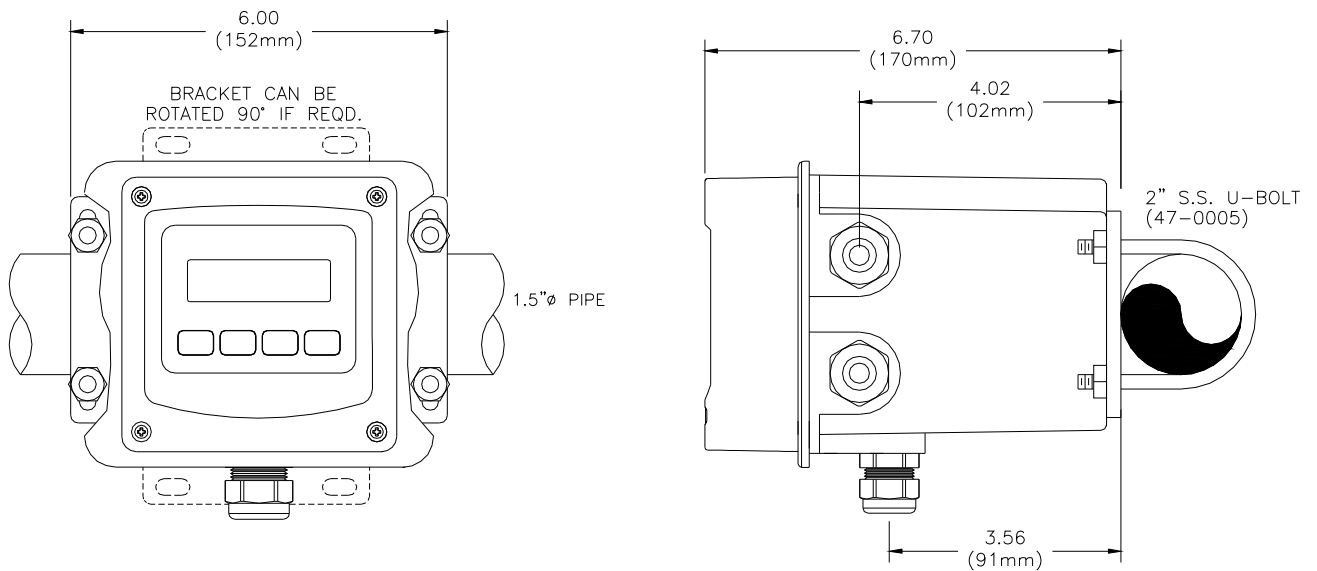

Figure 4 - Pipe Mounting Diagram

2.3 Panel Mount Monitor

Panel mounting uses the panel mounting flange molded into the rear section of the enclosure. Figure 5 provides dimensions for the panel cutout required for mounting.

The panel mounting bracket kit must be ordered separately (part number 05-0094). This kit contains a metal retainer bracket that attaches to the rear of the enclosure, 4 screws for attachment of this bracket, and a sealing gasket to insure that the panel mounted monitor provides a water tight seal when mounted to a panel.

The sealing gasket must first be attached to the enclosure. The gasket contains an adhesive on one side so that it remains in place on the enclosure. Remove the protective paper from the adhesive side of the gasket and slide the gasket over the back of the enclosure so that the adhesive side lines up with the back of the enclosure flange. Once in place, you can proceed to mount the monitor in the panel.

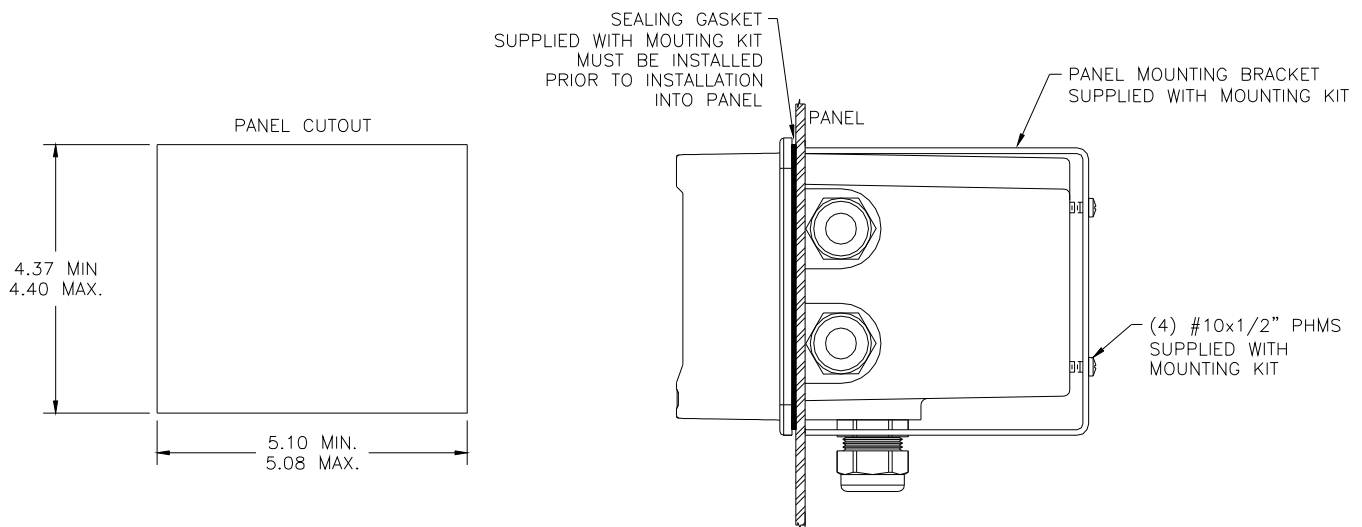

Figure 5 - AC Pwr Panel Mount Cutout

Part 3 – Sensor/Flowcell Mounting

3.1 General

The Q25C4 Conductivity Sensor is designed for industrial and municipal process applications. Mounting options include flow-through, submersion, insertion (special hardware required), or sanitary mount depending on the type of sensor purchased. The sensor-to-analyzer distance must not exceed 60 feet (18.2 meters).

Calibrate the sensor before placing it into the process. See Part 7 of this manual for detailed calibration instructions.

The sensor comes with a removable guard that surrounds the electrode face, except for flow type sensors. This guard minimizes interference effects in tight locations where the sensor face is close to surrounding objects. If it is removed, take care to leave at least 1 in³ of space in front of the electrodes. If the guard is to be used, the sensor must be calibrated with it in place, since the guard affects the sensor cell constant.

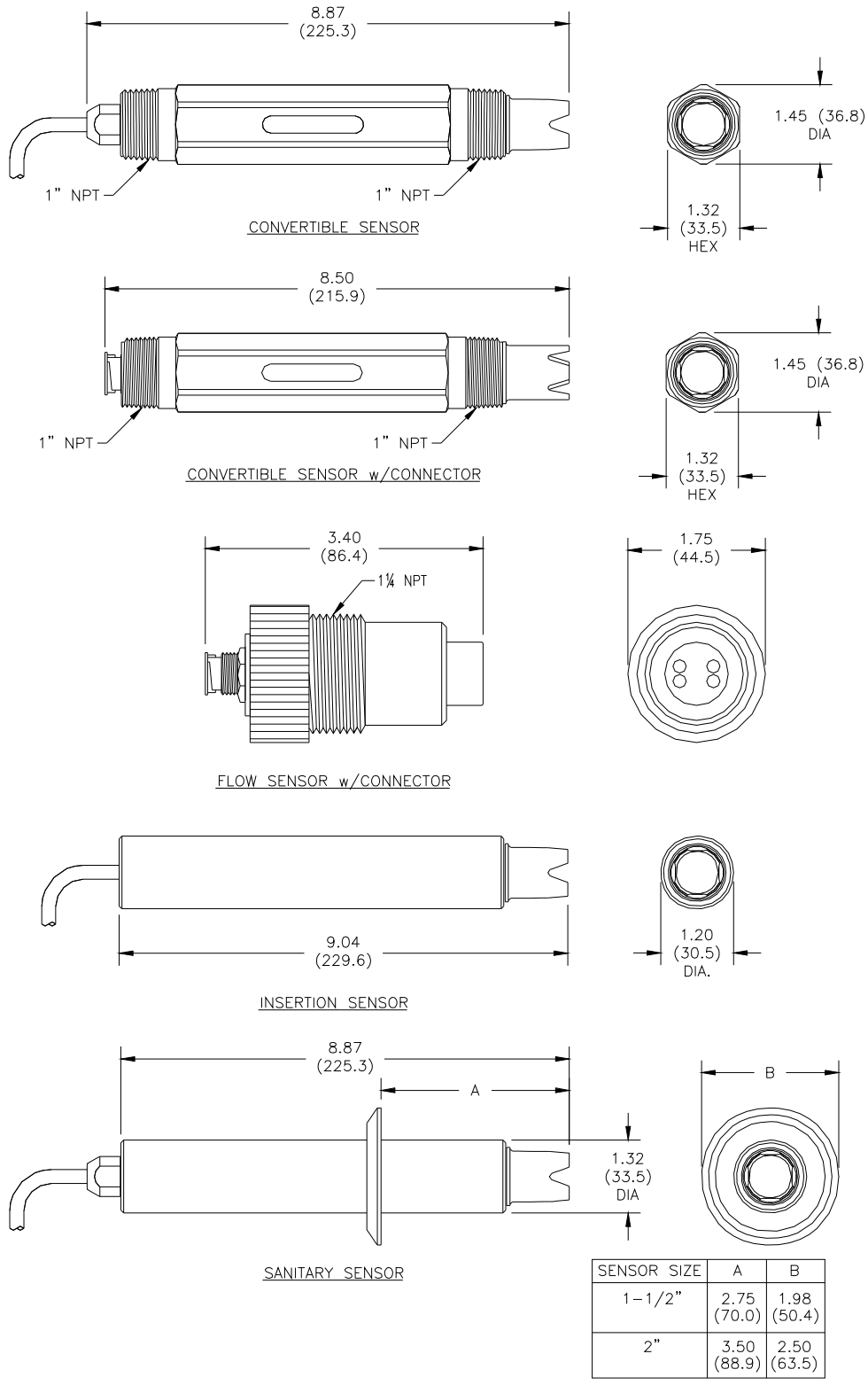

Figure 6 - Q25C4 Sensor Dimensions

3.2 Sealed Flowcell

Applications where the sample inlet flow is well controlled can use a simpler sealed flowcell. Using this flowcell requires that flow be controlled externally to about 400 cc/min. Variable flow rate or variable pressure will cause unstable readings in this flowcell. ATI offers a special flow control element that can be used ahead of this flowcell on the incoming sample line. The flow control is part no. (55-0048). It will control the inlet flowrate at 400 cc/min. with inlet pressure variations from 5-150 PSIG. A 50 micron y-strainer ahead of the flow control element is recommended. The sealed flowcell provides a drain vent with check valve to avoid pulling a vacuum on the flow chamber.

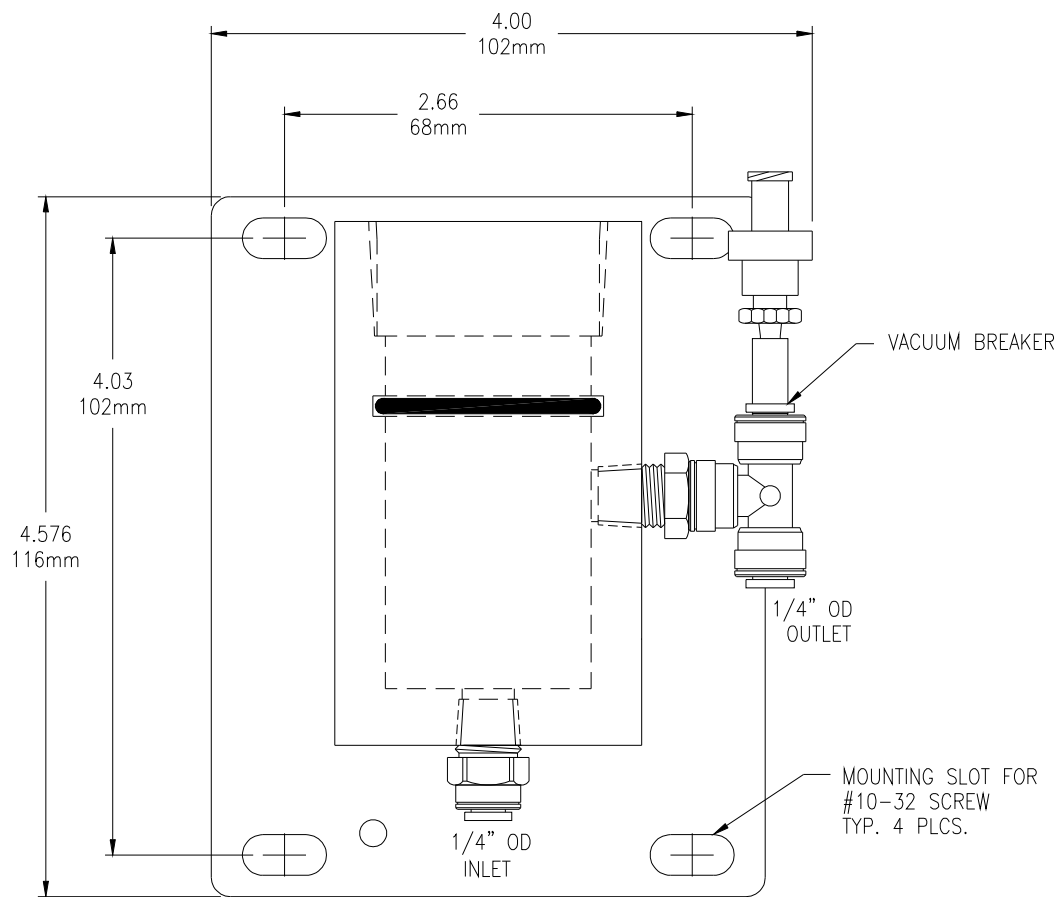

Figure 7 - Sealed Flowcell Details

3.3 Flow Tee Mounting

Convertible sensors may be used in a 1" flow tee as shown in Figure 8. The flow tee is a modified pipe fitting that accommodates the pipe thread on the front of the sensor. Sample must flow directly against the face of the sensor as shown. The sensor may be mounted horizontally provided that the outlet flow is pointed up to avoid "air locking" in the tee.

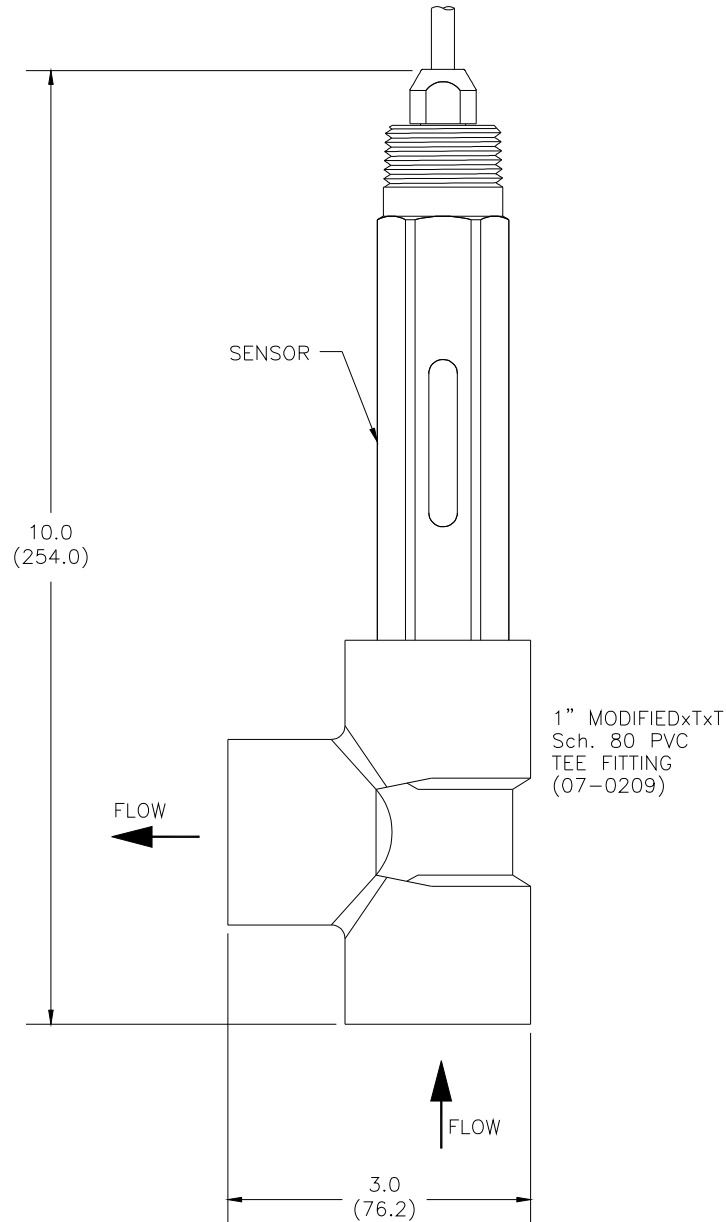

Figure 8 - Flow Through Tee Mount

3.4 Union Mounting

For mounting the sensor in larger pipe and allowing for easy sensor removal, a 1½” or 2” union mount adapter system is available. This arrangement allows connection of the sensor to pipe sizes up to 2 inches (using adapters if necessary) while allowing easy removal without twisting sensor wires. Contact ATI for part numbers and prices for union mount assemblies and associated pipe tees.

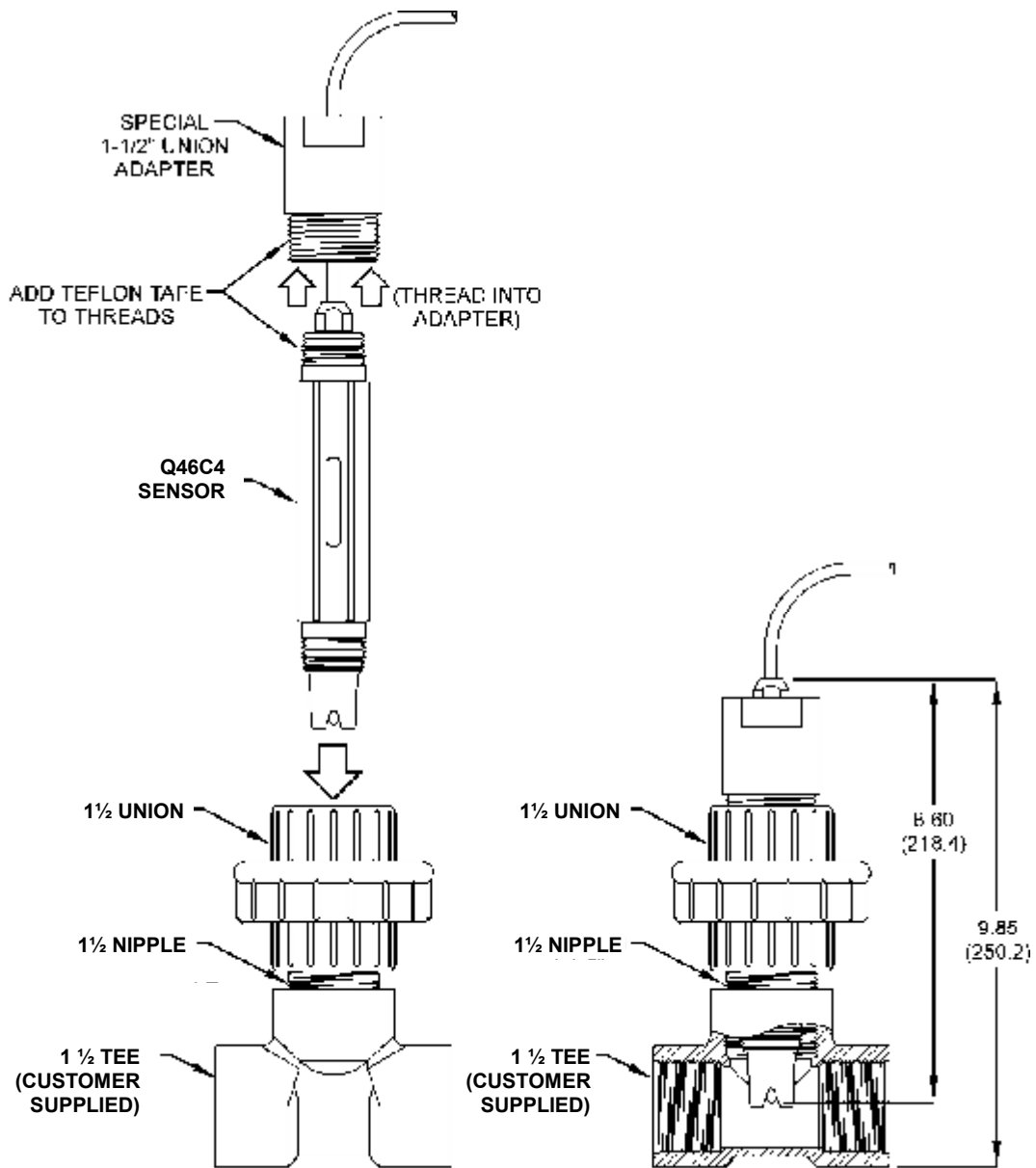

Figure 9 - 1.5" Union Mount

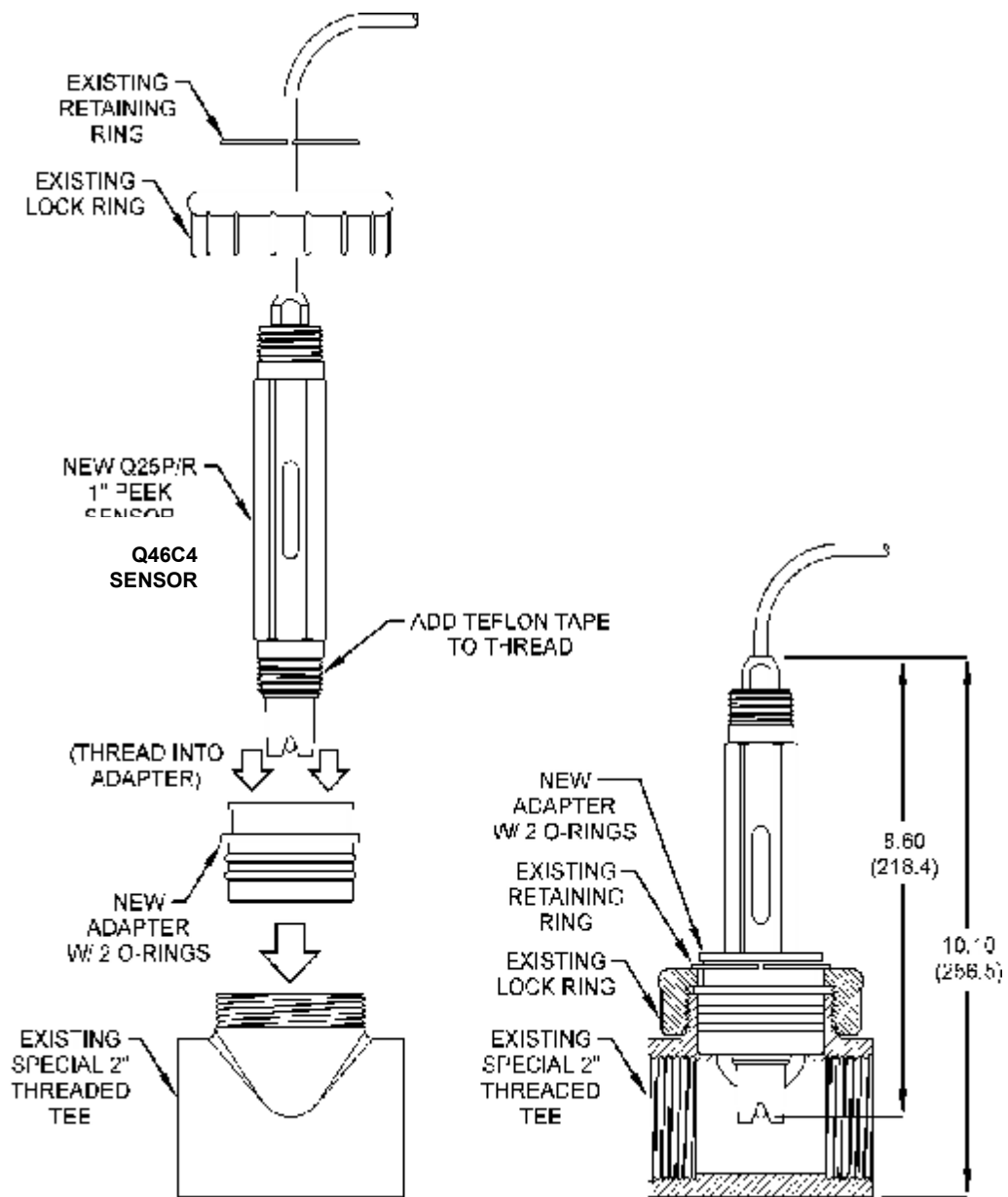

Figure 10 - 2" Union Mount

3.5 Submersion Mounting

When using this conductivity sensor for submersion applications, mount the sensor to the end of a 1" mounting pipe using a 1" coupling. ATI's (00-0628) mounting assembly shown in 11 is available for submersible applications. This assembly is designed to mount to standard handrails and facilitates insertion and removal of the sensor.

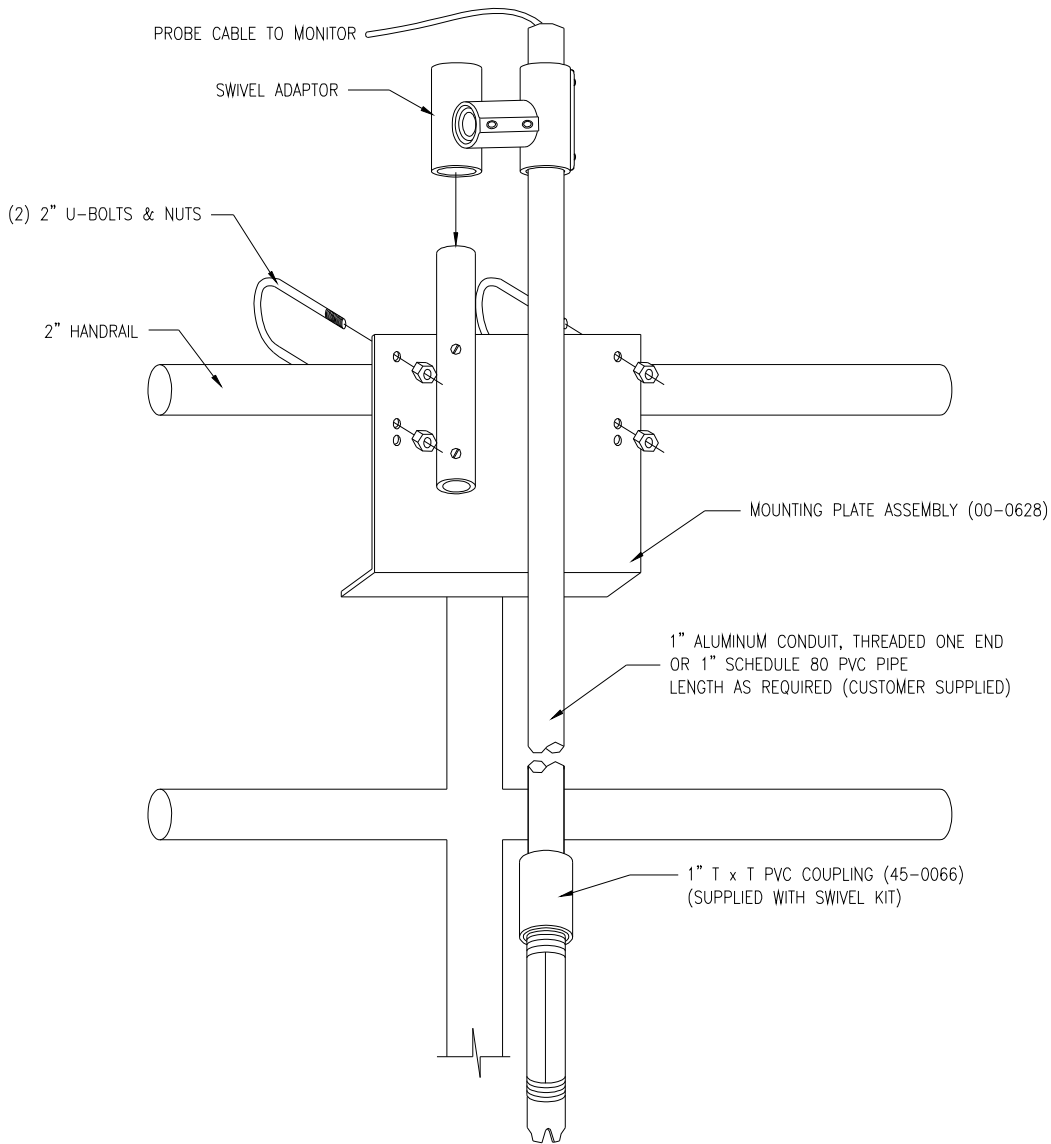

Figure 11 - Sensor Submersion Mount

3.6 Insertion Mounting

Special insertion mounting hardware is available for applications requiring the removal of the sensor from a process line or tank without shutting off the sample flow in the line. Figure 12 & 13 show typical insertion assemblies.

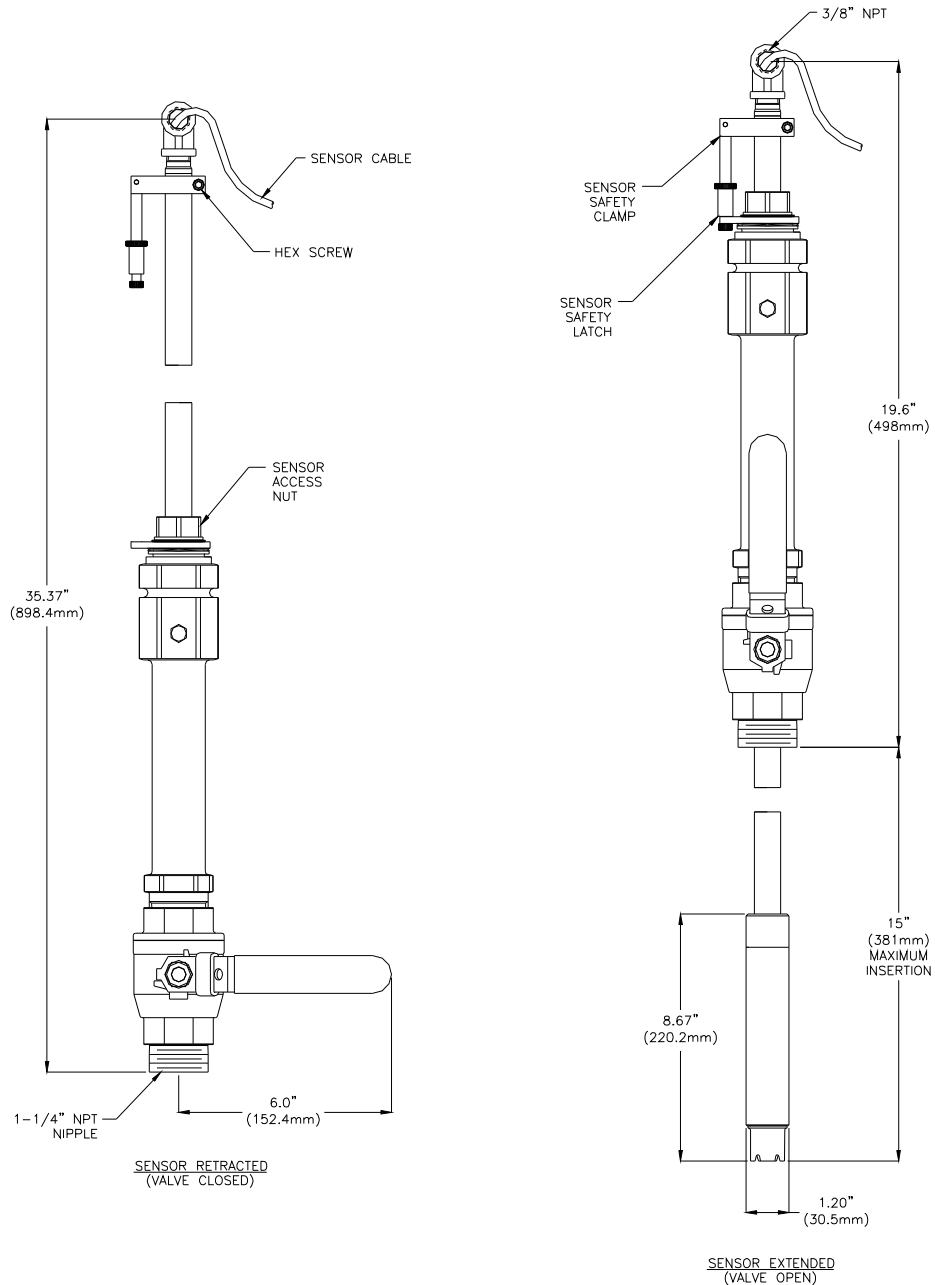

Figure 12 - S.S. Sensor Insertion Mount

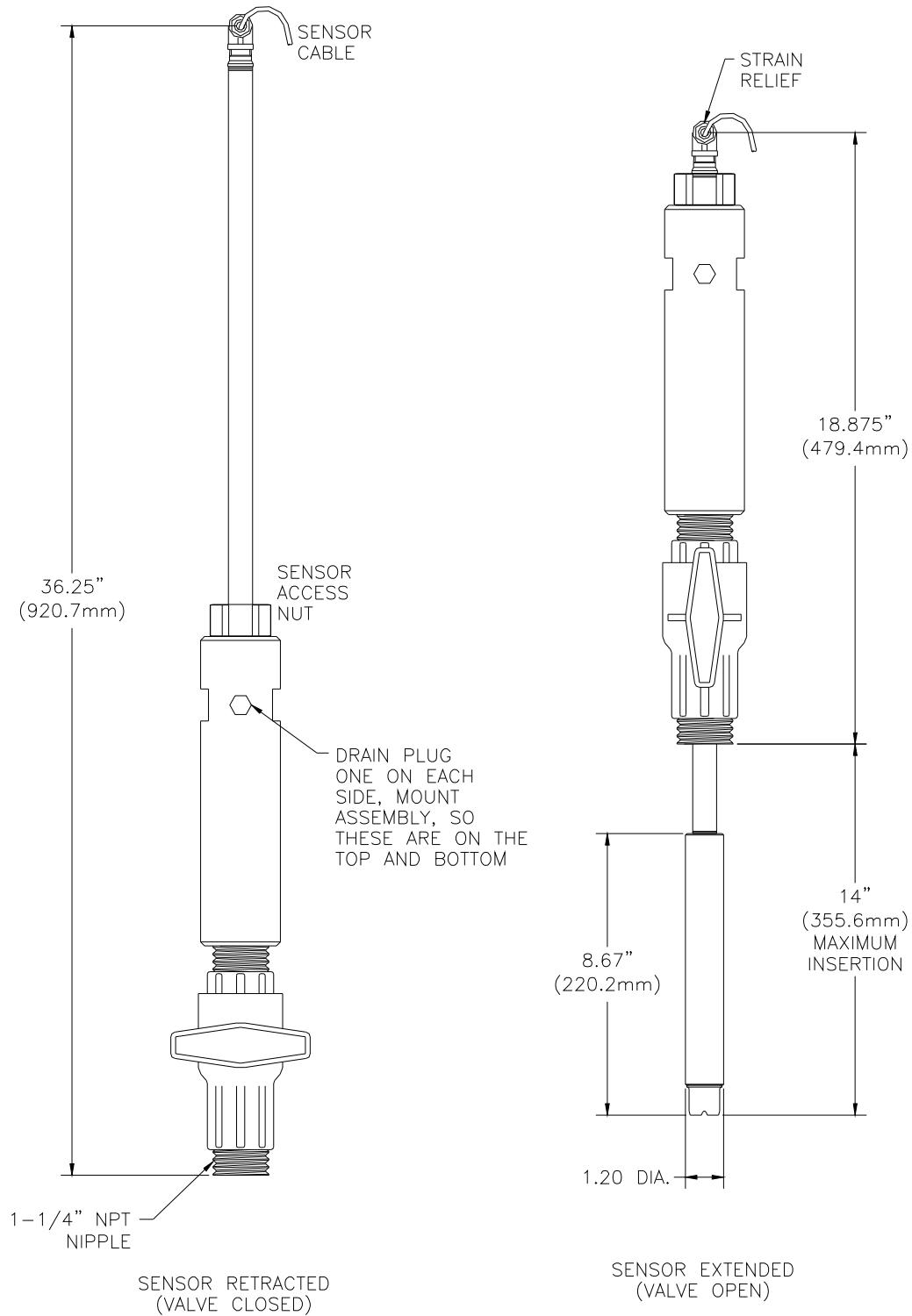

Figure 13 - CPVC Sensor Insertion Mount

Part 4 – Electrical Installation

4.1 General

The Q46 is powered in one of two ways, depending on the version purchased. The 12-24 VDC powered analyzer requires a customer supplied DC power supply. The 90-260 VAC version requires line power. Please verify the type of unit before connecting any power.



WARNING: Do not connect AC line power to the DC version. Severe damage will result.

Important Notes:

1. Use wiring practices that conform to all national, state and local electrical codes. For proper safety as well as stable measuring performance, it is important that the earth ground connection be made to a solid ground point from TB7. The AC power supply contains a single 630mA slo-blo fuse (Wickmann/Littlefuse #372-0630). The fuse **F1** is located adjacent to **TB7** and is easily replaceable.
2. Do NOT run sensor cables or instrument 4-20 mA output wiring in the same conduit that contains AC power wiring. AC power wiring should be run in a dedicated conduit to prevent electrical noise from coupling with the instrumentation signals.
3. This analyzer must be installed by specifically trained personnel in accordance with relevant local codes and instructions contained in this operating manual. Observe the analyzer's technical specifications and input ratings. Proper electrical disconnection means must be provided prior to the electrical power connected to this instrument, such as a circuit breaker - rated 250 VAC, 2 A minimum. If one line of the line power mains is not neutral, use a double-pole mains switch to disconnect the analyzer.
4. Repeated problems with lightning strikes damaging sensitive instrumentation are often attributed to poorly bonded earth grounds in the instrument power source. The protection schemes incorporated into this analyzer cannot operate to maximum efficiency unless the ground connection is at its' absolute lowest impedance.

There is no standard ground resistance universally recognized. Many agencies recommend a ground resistance value of 5 ohms or less. The NEC recommends an impedance to ground of less than 25 ohms, and less than 5 ohms where sensitive equipment is installed. Power sources feeding sensitive instruments like the Q46H/79PR should have the lowest possible impedance to ground.

4.2 Power Connection

Verify the AC power supply requirement before installing. Also verify that power is fully disconnected before attempting to wire.

Q46 systems are supplied with 5 cable gland fittings for sealing cable entries.

Connect HOT, NEUTRAL, and GROUND to the matching designations on terminal strip **TB7**.

WARNING

Disconnect line power voltage BEFORE connecting line power wires to Terminal TB7 of the power supply. The power supply accepts only standard three-wire single phase power. AC power supplies are configured for 90-260 VAC operation at the factory at time of order, and the power supply is labeled as such. Do NOT connect voltages other than the labeled requirement to the input.

The two analog outputs for the standard system are present at terminal TB1. The loop-load limitation in this configuration is 500 Ohms maximum for each output. Also note that these two outputs are completely isolated from each other to insure that ground loops do not result from the connection of both outputs to the same device such as a PLC or DCS.

A ribbon cable connects the power supply assembly with the microprocessor assembly located in the front section of the enclosure. This cable may be unplugged from the front section of the monitor if service is needed, but should normally be left in place during installation.

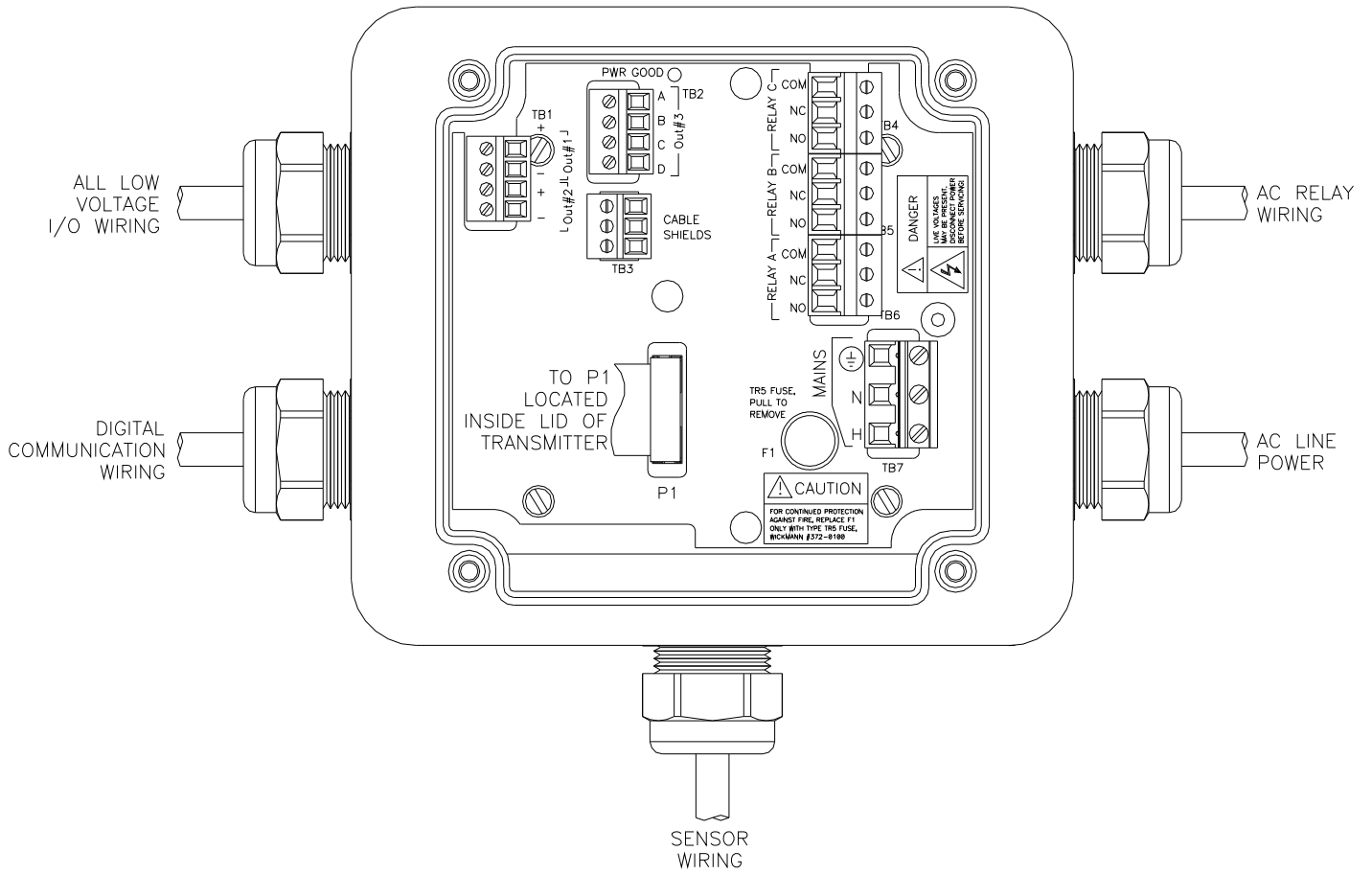

Figure 14 - Q46 Connection Layout

4.3 Relay Connection

Three SPDT relays are provided on the power supply board. None of the relay contacts are powered. The user must supply the proper power to the contacts. For applications that require the same switched operating voltage as the Q46 (115 or 230 V), power may be jumpered from the power input terminals at **TB7**. Relay wiring is connected at **TB4**, **TB5**, and **TB6** as shown below. Note that the relay contact markings are shown in the NORMAL mode. Programming a relay for “Failsafe” operation reverses the NO and NC positions in this diagram (Figure 13).

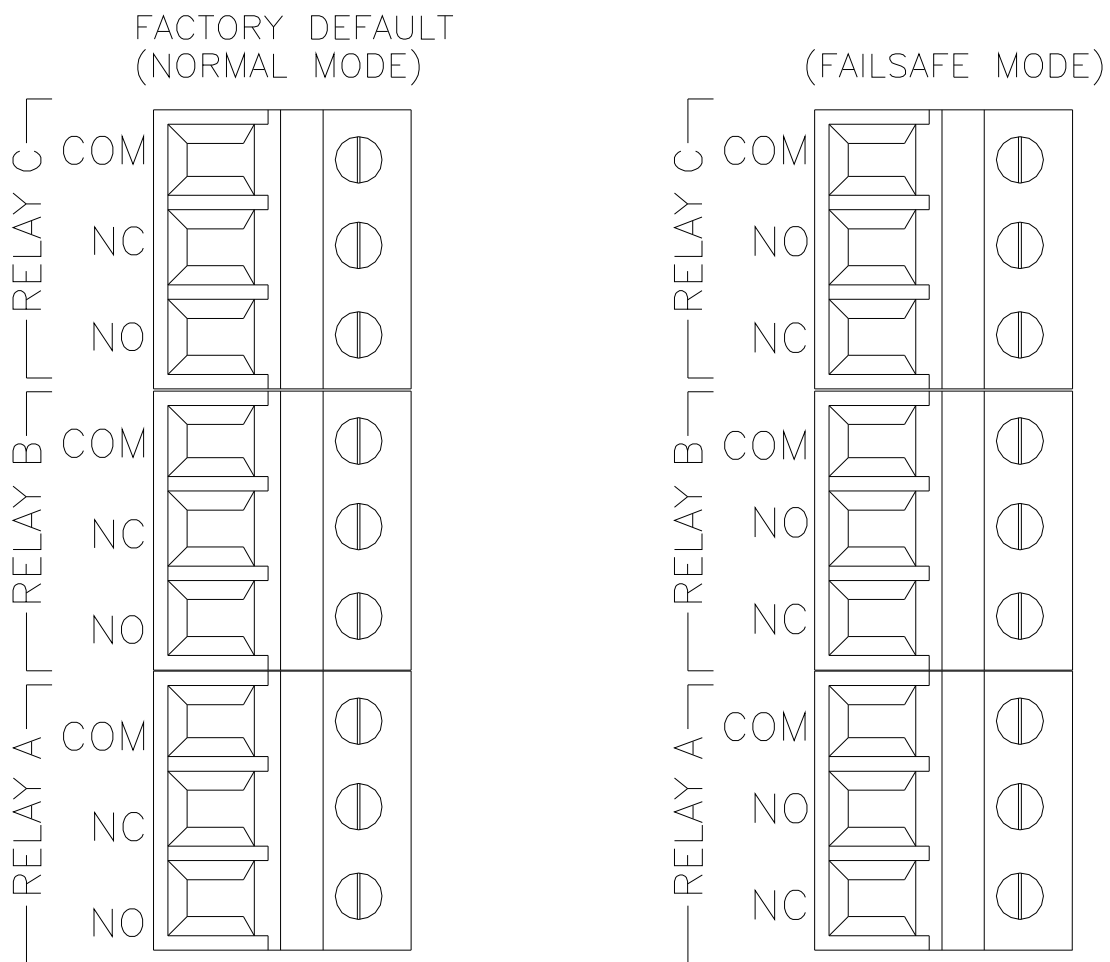

Figure 15 - Relay Connections

4.4 Optional Output or Relay Connections

TB2, is used to connect to the optional 3-relay card (Figure 20) **OR** the optional third analog output, Out#3, (Figure 21). The Q46 can be configured for only one of these optional features, and the hardware for either option must be factory installed.

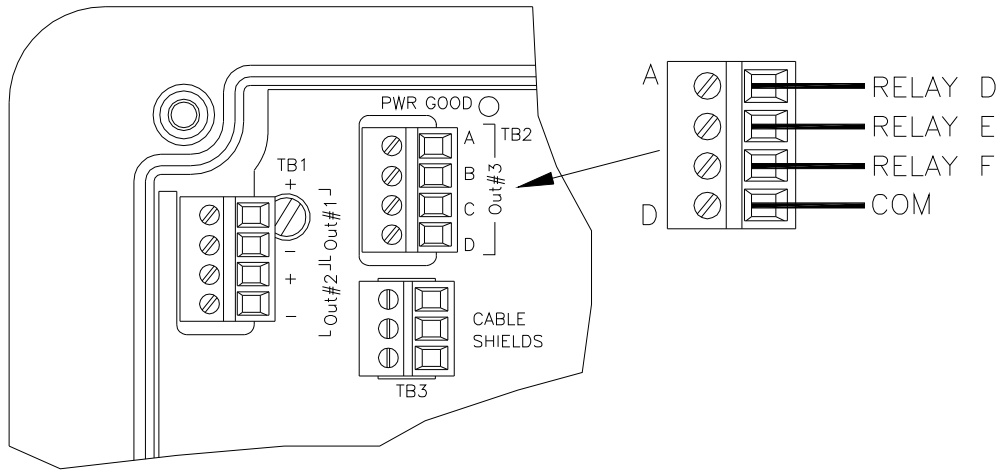

Figure 16 - Optional Relay Board Wiring

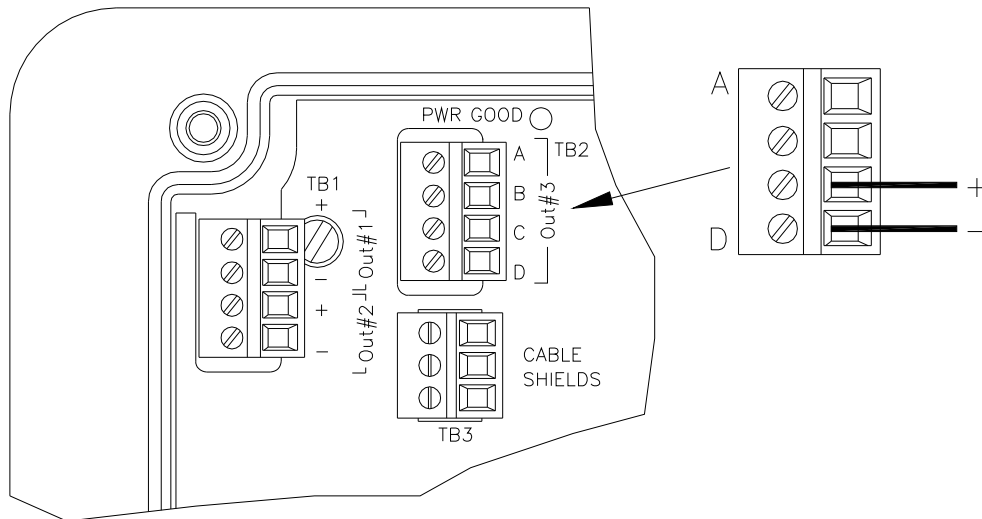

Figure 17 - Optional Analog Output Wiring

4.5 Sensor Wiring

The sensor cable can be quickly connected to the Q46 terminal strip by matching the wire colors on the cable to the color designations on the label in the monitor. A junction box is also available to provide a break point for long sensor cable runs. Route signal cable away from AC power lines, adjustable frequency drives, motors, or other noisy electrical signal lines. Do not run sensor or signal cables in conduit that contains AC power lines or motor leads.

When installing conductivity monitors and sensors, we recommend keeping the sensor cable as short as is practical. This will minimize potential noise problems.

Standard convertible sensors, insertion sensors, and sanitary sensors have cable permanently attached to the sensor. This cable contains double shielded conductors to minimize noise problems in heavy industrial environments. Convertible sensors with connectors and flow type sensors use a slightly different cable assembly with only a single shield. This assembly is sufficient for many applications where EMI/RFI problems are not severe. Figure 18 & 19 show the two different cable assembly terminations.

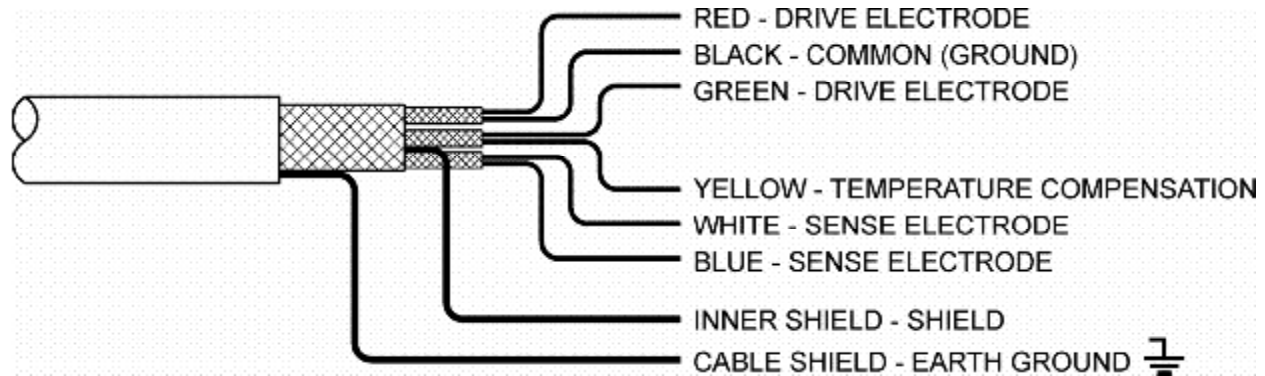

Figure 18 - Standard Double Shielded Cable

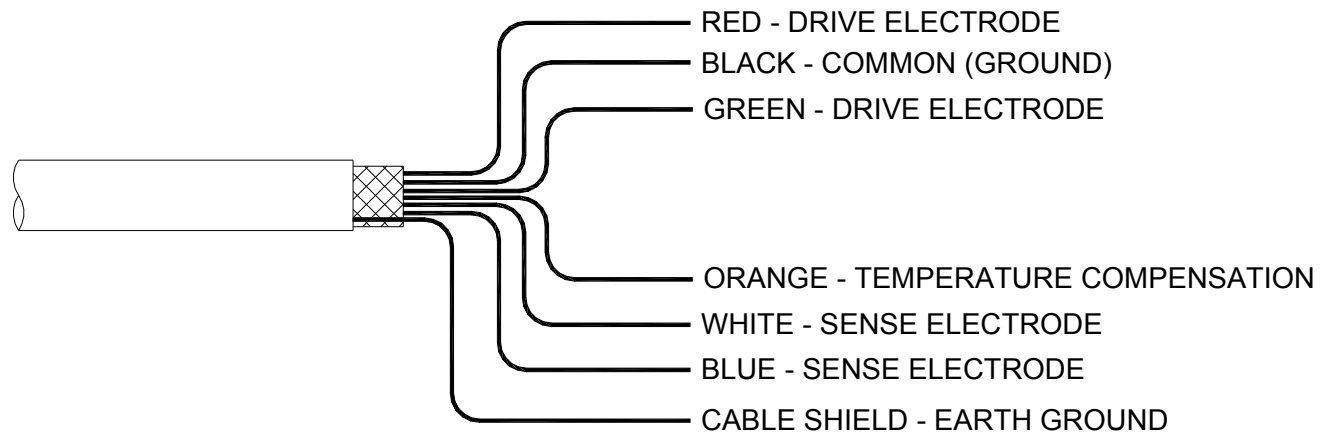

Figure 19 - Detachable Single Shielded Cable



DANGER: DO NOT connect sensor cable to power lines. Serious injury may result.

Take care to route sensor cable away from AC power lines, adjustable frequency drives, motors, or other noisy electrical signal lines. Do not run signal lines in the same conduit as AC power lines. Run signal cable in dedicated metal conduit if possible. For optimum electrical noise protection, run an earth ground wire to the ground terminal in the transmitter.

Refer to Figure 14, Figure 20, and Figure 22 for illustrative details on electrical installation.



Only ATI's custom 6-wire shielded interconnect cable should be used when connecting the Model Q25C4 sensor to the analyzer. This high-performance, double shielded, polyethylene jacketed cable is specially designed to provide the proper signal shielding for the sensor used in this system. Substituted cables may cause problems with system performance.

Note: If sensor is experiencing Low-Slope or Low-Output conditions, due To poor Earth Ground Connections, move the Shield connection from P/S board to alternate location on lid, where indicated with an "S".

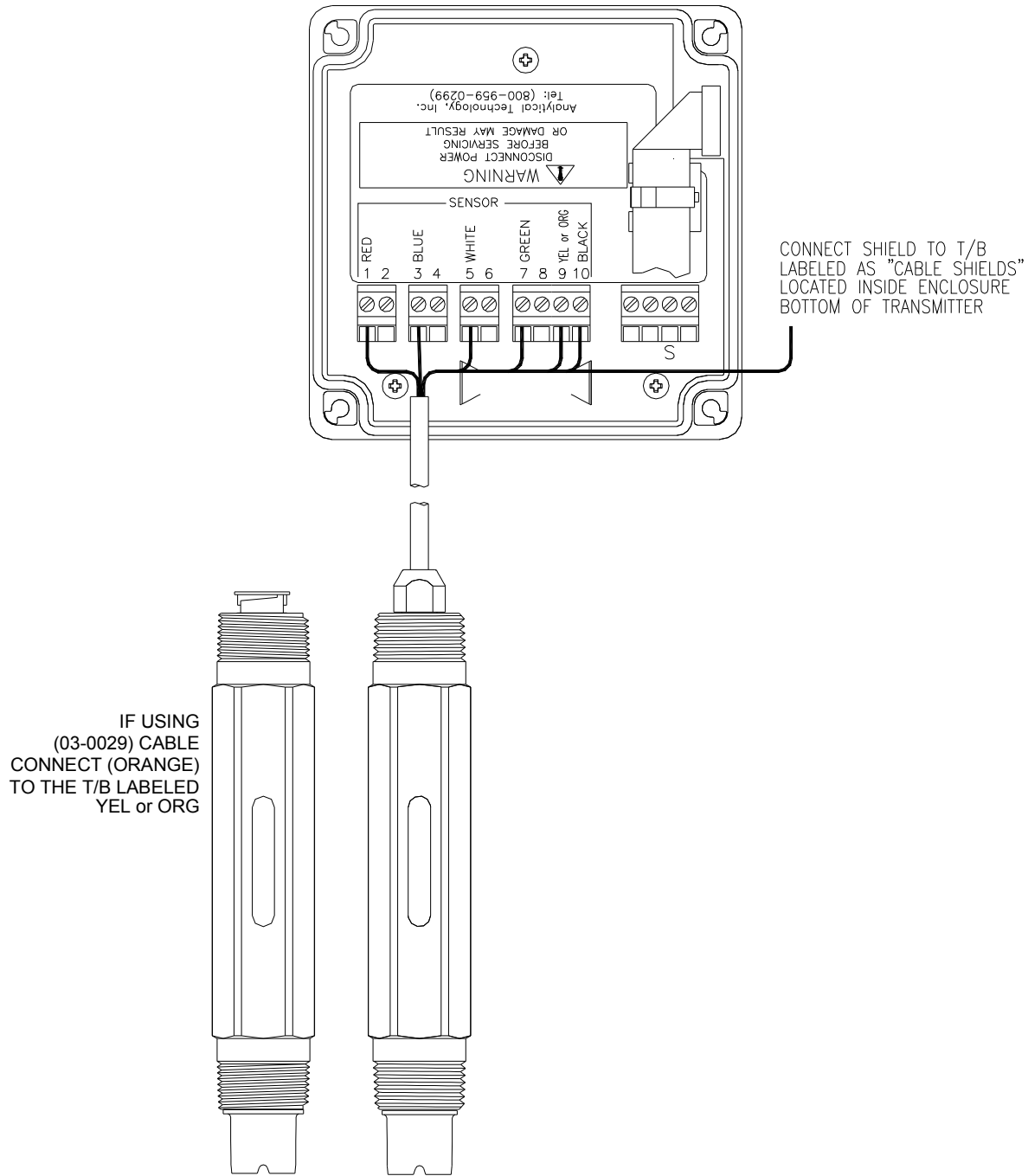

Figure 20 - Q46C4 Sensor Connections

4.6 Direct Sensor Connection

Sensor connections are made in accordance with Figure 20. The sensor cable can be routed into the enclosure through one of cord-grips supplied with the unit. Routing sensor wiring through conduit is only recommended if a junction box is to be used. Some loose cable is needed near the installation point so that the sensor can be inserted and removed easily depending on the installation type.

Cord-grips used for sealing the cable should be snugly tightened after electrical connections have been made to prevent moisture incursion. When stripping cables, leave adequate length for connections in the transmitter enclosure as shown below. The standard 20 ft. sensor cable normally supplied with the system is already stripped and ready for wiring. This cable can be cut to a shorter length if desired to remove extra cable in a given installation. Do not cut the cable so short as to make installation and removal of the sensor difficult.

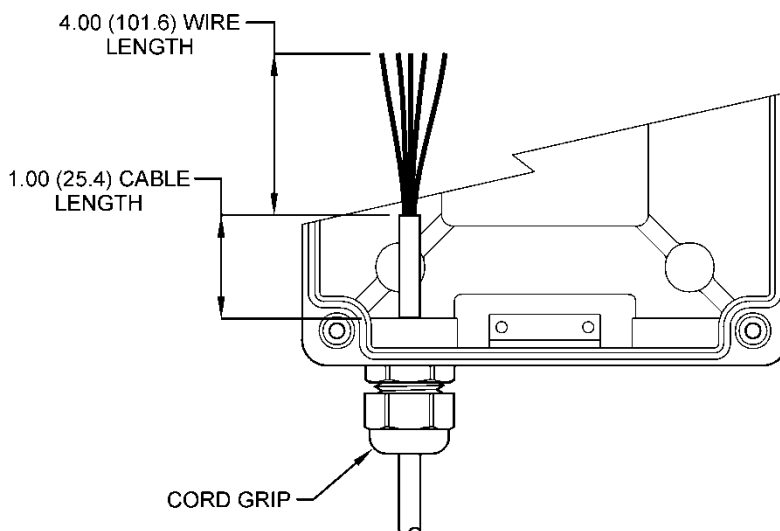

Figure 21 - Sensor Cable Preparation

4.7 Junction Box Connection

For installations where the sensor is to be located more than 30 feet from the monitor (max. 60 feet), a junction box must be used. The following drawing shows the Junction Box wiring diagram.

Note: If sensor is experiencing Low-Slope or Low-Output conditions, due To poor Earth Ground Connections, move the Shield connection from P/S board to alternate location on lid, where indicated with an “S”.

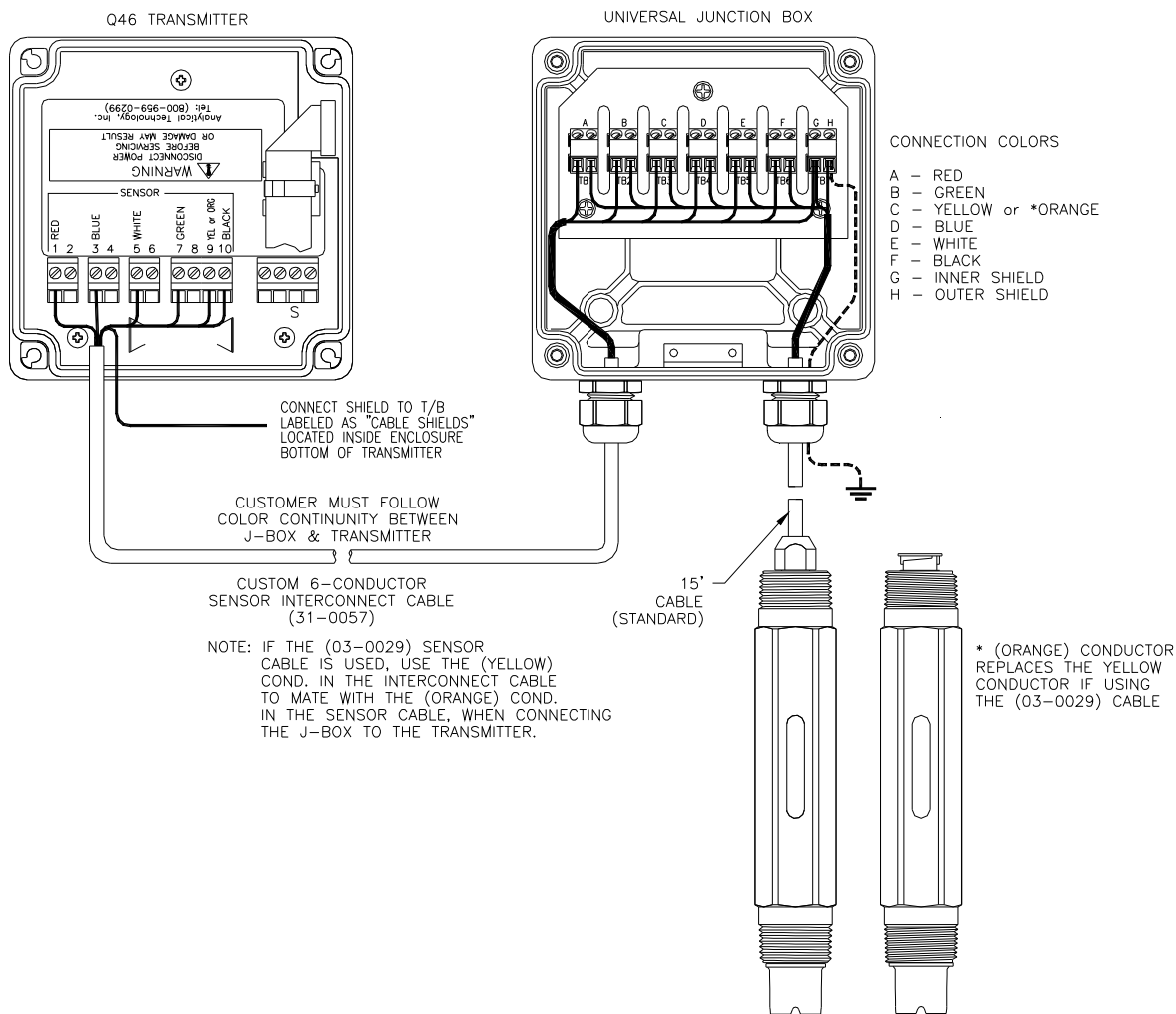

Figure 22 - Junction Box Interconnect Wiring

Part 5 – Configuration

5.1 User Interface

The user interface for the Q46 Series instrument consists of a custom display and a membrane keypad. All functions are accessed from this user interface (no internal jumpers, pots, etc.).

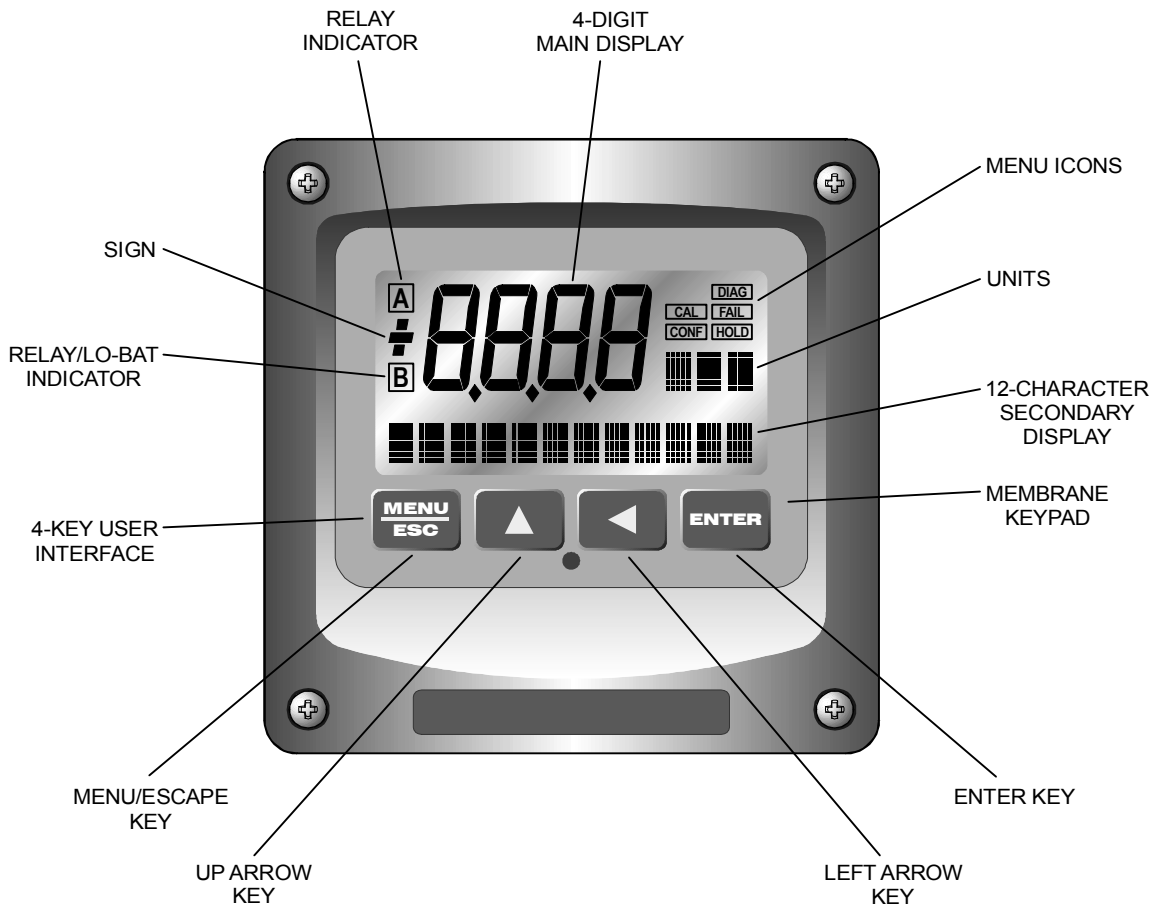

Figure 23 - User Interface

5.11 Keys

All user configurations occur through the use of four membrane keys. These keys are used as follows:

- MENU/ESC** To scroll through the menu section headers or to escape from anywhere in software. The escape sequence allows the user to back out of any changes in a logical manner. Using the escape key aborts all changes to the current screen and backs the user out one level in the software tree. The manual will refer to this key as either MENU or ESC, depending upon its particular function.
- UP (arrow)** To scroll through individual list or display items and to change number values.
- LEFT (arrow)** To move the cursor from right to left during changes to a number value.
- ENTER** To select a menu section or list item for change and to store any change.

5.12 Display

The large custom display provides clear information for general measurement use and user configuration. There are three main areas of the display: the main parameter display, the secondary message line, and the icon area.

- Main Parameter** During normal operation, the main parameter display indicates the present process input with sign and units. This main display may be configured to display any of the main measurements that the system provides. During configuration, this area displays other useful set-up information to the user.



Lower Line

During normal operation, the lower line of the display indicates user-selected secondary measurements that the system is making. This also includes calibration data from the last calibration sequence and the transmitter model number and software version. During configuration, the lower line displays menu items and set-up prompts to the user. Finally, the lower line will display error messages when necessary. For a description of all display messages, refer to Section 8.5.

**Icon Area**

The icon area contains display icons that assist the user in set-up and indicate important states of system functions. The CAL, CONFIG, CNTRL, and DIAG icons are used to tell the user what branch of the software tree the user is in while scrolling through the menu items. This improves software map navigation dramatically. Upon entry into a menu, the title is displayed (such as CAL), and then the title disappears to make way for the actual menu item. However, the icon stays on.

**HOLD**

The HOLD icon indicates that the current output of the transmitter has been put into output hold. In this case, the output is locked to the last input value measured when the HOLD function was entered. HOLD values are retained even if the unit power is cycled.

FAIL

The FAIL icon indicates that the system diagnostic function has detected a problem that requires immediate attention. This icon is automatically cleared once the problem has been resolved.

Relay Area A/B

The relay area contains two icons that indicate the state of the system relays. Relay C is normally configured for FAIL indication, so it is only displayed on the lower MEASURE display line.

**5.2 Software**

The software of the Q46C4 is organized in an easy to follow menu-based system. All user settings are organized under five menu sections: Measure, Calibration [CAL], Configuration [CONFIG], Control [CONTROL] and Diagnostics [DIAG].

Note: The default Measure Menu is display-only and has no menu icon.

5.2.1 Software Navigation

Within the CAL, CONFIG, CONTROL, and DIAG menu sections is a list of selectable items. Once a menu section (such as CONFIG) has been selected with the MENU key, the user can access the item list in this section by pressing either the ENTER key or the UP arrow key. The list items can then be scrolled through using the UP arrow key. Once the last item is reached, the list wraps around and the first list item is shown again. The items in the menu sections are organized such that more frequently used functions are first, while more permanent function settings are later in the list. See Figure 24 - Software Map

for a visual description of the software.

Each list item allows a change to a stored system variable. List items are designed in one of two forms: simple single variable, or multiple variable sequences. In the single variable format, the user can quickly modify one parameter - for example, changing temperature display units from °F to °C. In the multiple variable sequence, variables are changed as the result of some process. For example, the calibration of conductivity generally requires more than one piece of information to be entered. The majority of the menu items in the software consist of the single variable format type.

Any data that may be changed will be flashing. This flashing indicates user entry mode and is initiated by pressing the ENTER key. The UP

arrow key will increase a flashing digit from 0 to 9. The LEFT arrow key moves the flashing digit from right to left. Once the change has been completed, pressing ENTER again stores the variable and stops the flashing. Pressing ESC aborts the change and also exits user entry mode.

The starting (default) screen is always the Measure Menu. The UP arrow key is used to select the desired display. From anywhere in this section the user can press the MENU key to select one of the four Menu Sections.

The UP arrow icon next to all list items on the display is a reminder to scroll through the list using the UP arrow key.

To select a list item for modification, first select the proper menu with the MENU key. Scroll to the list item with the UP arrow key and then press the ENTER key. This tells the system that the user wishes to perform a change on that item. For single item type screens, once the user presses the ENTER key, part or all of the variable will begin to flash, indicating that the user may modify that variable using the arrow keys. However, if the instrument is locked, the transmitter will display the message **Locked!** and will not enter user entry mode. The instrument must be unlocked by entering the proper code value to allow authorized changes to user entered values. Once the variable has been reset, pressing the ENTER key again causes the change to be stored and the flashing to stop. The message **Accepted!** will be displayed if the change is within pre-defined variable limits. If the user decides not to modify the value after it has already been partially changed, pressing the ESC key aborts the modification and returns the entry to its original stored value.

In a menu item which is a multiple variable sequence type, once the ENTER key is pressed there may be several prompts and sequences that are run to complete the modification. The ESC key can always be used to abort the sequence without changing any stored variables.

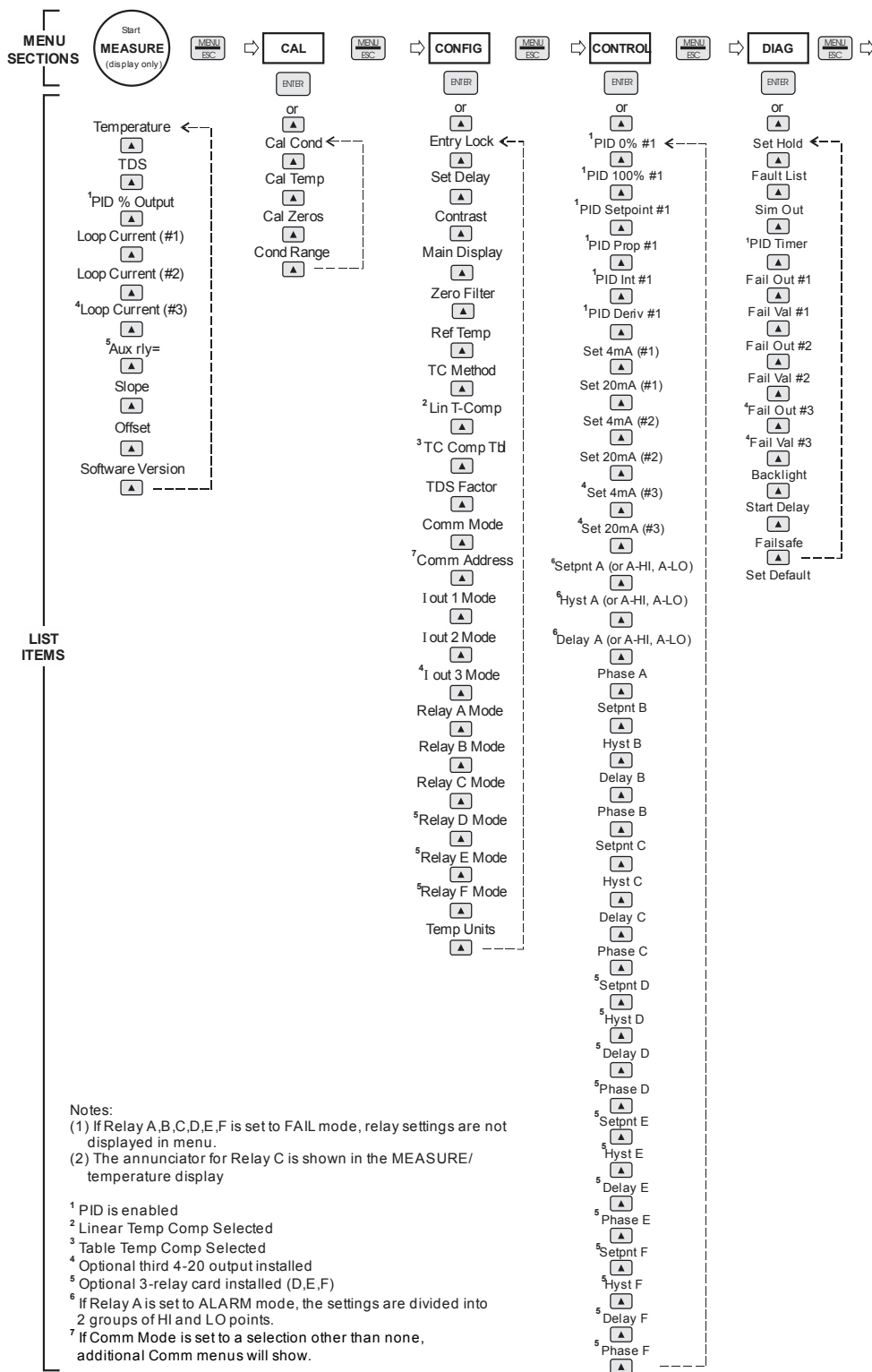

Figure 24 - Software Map

5.22 Measure Menu [MEASURE]

The default menu for the system is the display-only menu MEASURE. This menu is a display-only measurement menu, and has no changeable list items. When left alone, the instrument will automatically return to this menu after approximately 30 minutes. While in the default menu, the UP arrow allows the user to scroll through the secondary variables on the lower line of the display. A brief description of the fields in the basic transmitter version is as follows:

TRANSMITTER MEAS SCREENS:

25.7°C	Temperature display. Can be displayed in °C or °F, depending on user selection. A small “m” to the left side of the temperature indicates the transmitter has automatically jumped to a manual 25°C setting due to a failure with the temperature signal input. An L ^C symbol to the left of the temperature will appear if relay C activates.
TDS = 200 ppm	Total Dissolved Solids (TDS). Displays TDS of process.
100% 20.00 mA	PID Status screen (if enabled.) Shows the present controller output level on left, and actual transmitter current on the right. The controller can be placed in manual while viewing this screen by pressing and holding the ENTER key for 5 seconds until a small flashing “m” appears on the screen. At that point the controller output can be adjusted up or down using the UP and LEFT arrow keys. To return to automatic operation, press and hold the ENTER key for 5 seconds and the “m” will disappear.
#1 4.00 mA	Analyzer output current # 1.
#2 12.00 mA	Analyzer output current # 2.
#3 20.00 mA	Analyzer output current # 3 (if option included.)
Aux relay=D,E,F	Auxilliary relay annunciators (if option included.)
Slope	The slope is an indication of the sensor output as compared to the theoretical output if the sensor were perfect. The slope value is calculated after completion of a calibration as described in Section 7 of this manual.

Q46C4 v4.00 Transmitter software version number.

Note: A display test (all segments ON) can be actuated by pressing and holding the ENTER key while viewing the model/version number on the lower line of the display.

The MEASURE screens are intended to be used as a very quick means of looking up critical values during operation or troubleshooting.

5.23 Calibration Menu [CAL]

The calibration menu contains items for frequent calibration of user parameters. There are five items in this list: Cal Cond, Cell Temp, Cal Const, and Cal Zeros.

Cal Cond The conductivity calibration function allows the user to adjust the transmitter offset and span reading to match reference buffers, or to adjust the sensor offset to match the sample reading. See Part 7 - Calibration for more details.

Cal Temp The temperature calibration function allows the user to adjust the offset of the temperature response by a small factor of $\pm 5^{\circ}\text{C}$. The temperature input is factory calibrated to very high accuracy. However, long cable lengths and junction boxes may degrade the accuracy of the temperature measurement in some extreme situations. Therefore, this feature is provided as an adjustment. See Part 7 - Calibration for more details.

Cal Zeros This function calibrates all range zero-points to the specific sensor being used. This function is only required to be performed once at initial start-up or when the sensor has been replaced. See Part 7 - Calibration for more details.

Cond Range This function allows the user to set the display range of the transmitter for a specific application. Once set, all output functions use this display range to establish configuration settings. The default range is 0-200.0 mS. Press ENTER to initiate user entry mode, and the value will flash. Use the arrow key to modify the range for the desired range and then press ENTER.

5.24 Configuration Menu [CONFIG]

The Configuration Menu contains all of the general user settings:

- Entry Lock** This function allows the user to lock out unauthorized tampering with instrument settings. All settings may be viewed while the instrument is locked, but they cannot be modified. The Entry Lock feature is a toggle-type setting; that is, entering the correct code will lock the transmitter and entering the correct code again will unlock it. The code is preset at a fixed value. Press ENTER to initiate user entry mode and the first digit will flash. Use arrow keys to modify value. **See end of manual for the Q46C4 lock/unlock code.** Press ENTER to toggle lock setting once code is correct. Incorrect codes do not change state of lock condition.
- Set Delay** The delay function sets the amount of damping on the instrument. This function allows the user to apply a first order time delay function to the conductivity measurements being made. Both the display and the output value are affected by the degree of damping. Functions such as calibration are not affected by this parameter. The calibration routines contain their own filtering and stability monitoring functions to minimize the calibration timing. Press ENTER to initiate user entry mode, and the value will flash. Use the arrow keys to modify value; range is 0.1 to 9.9 minutes. Press ENTER to store the new value.
- Contrast** This function sets the contrast level for the display. The custom display is designed with a wide temperature range, Super-Twist Nematic (STN) fluid. Press ENTER to initiate user entry mode, and the value will flash. Use arrow keys to modify the value; range is 0 to 8 (0 being lightest). Press ENTER to update and store the new value.
- Main Display** This function allows the user to change the measurement in the primary display area, selecting between conductivity, Auto-Ranging conductivity, sensor temperature, or percent. Using this function, the user may choose to put temperature in the main display area and conductivity on the secondary, lower line of the display. Press ENTER to initiate user entry mode, and the entire value will flash. Use the UP arrow key to modify the desired display value. Press ENTER to store the new value.

Zero Filter This function forces the reading to zero when reading is below the entered value. For example, If the entered value were 2.1 mS, the display would read 0.0 mS when the measured value reached 2.0 mS. This feature is useful in blanking out very small and meaningless zero variability.

Ref Temp The reference temperature function sets the basis point for the linear temperature compensation methods. In most cases this setting should be left at the default of 25.0 °C.

Press ENTER to initiate user entry mode, and the entire value will flash. Use the arrow keys to modify the desired value; range is 0.0°C to 50.0°C. Press ENTER to update and store the new value. This setting appears in the Software Menu only if “Temp Mode” is set to **Lin**.

TC Method This function allows selection of the method used for the temperature compensation in the instrument. The choices are **1-Lin** or **2-Table**. The Lin (linear) method is by far the most common and should be used unless special measurements are being made.

Under the **2-Table** selection, you have the following choices.

1 Tbl: Ammonia compensation method. This method is specific only to ammonia measurement.

2 Tbl: Natural Water compensation method. This setting is limited to the temperature range of 0 - 35 °C.

NOTE: *Do not set the Temp Mode to a value other than **Lin** unless the instrument is specifically intended to measure one of the compounds listed above.*

This selection is critical for control of the internal diagnostics and compensation factors. Press ENTER to initiate user entry mode, and the entire value will flash. Use the UP arrow key to modify the desired value.

Lin T-Comp This function sets the correction slope value for the linear temperature compensation method and is used when the “Temp Mode” is set to **Lin**. Linear compensation is the method recommended for most aqueous solutions, and the value is typically 2.00 %/°C (25°C reference temperature) for neutral water. This is the factory default and it provides the

best compensation for most aqueous solutions. Other typical ranges include:

Acids: 1.0 to 1.6%/°C
Bases: 1.8 to 2.0%/°C
Salts: 2.2 to 3.0%/°C

NOTE: If the temperature units are changed between °C and °F (see Temp Units in this Section), the default setting for this output will change between 2.00 %/°C and 1.11%/°F accordingly.

Other compensation slopes for uncommon solutions may be found in chemical handbooks (such as the CRC). Press ENTER to initiate user entry mode, and the entire value will flash. Use the arrow keys to modify the desired value; entry range is 0.000%/°C (no compensation) to 4.000%/°C. Press ENTER to store the new value.

TDS Factor

This function sets the linear relationship of the TDS (total dissolved solids) reading to the conductivity measurement. The actual units for the slope are in mg/L/μS. The default value is 00.49 mg/L/μS.

Press ENTER to initiate user entry mode, and the entire value will flash. Use the arrow keys to modify the desired value; range is 00.00 mg/L/μS to 99.99 mg/L/μS. Press ENTER to update and store the new value.

- Com Mode** Sets digital communication mode of analyzer. Optional digital communication card must be plugged into the power supply slot for this function to work. Press ENTER to initiate user entry mode, and the entire value will flash. Use the UP arrow key to modify the desired value; selections include 1-None, 2- P-DP for Profibus DP, 3 – Modbus, 4 – Ethernet IP. Press ENTER to store the new value.
- Com Address** Sets bus address for digital communication mode of analyzer. Optional digital communication card must be plugged into the power supply slot for this function to work. Press ENTER to initiate user entry mode, and the entire value will flash. Use the UP arrow key to modify the desired value. Range is 1-125. Press ENTER to store the value.
- lout#1 Mode** This assigns the 4-20 mA output #1 to either μS (by selecting 1) or for PID output (by selecting 2)
- lout#2 Mode** This assigns the 4-20 mA output # 2 to Temperature (by selecting 1), μS (by selecting 2) or TDS mg/L (by selecting 3)
- *lout#3 Mode** **OPTIONAL.** This function sets analog output #3 for temperature, conductivity, or TDS. Press ENTER to initiate user entry mode, and the entire value will flash. Use the UP arrow key to modify the desired value; selections include 1- C/F for temperature, 2-uS, or 3-mg/l. Press ENTER to store the new value.
- Relay A Mode** Relay A can be used in three different ways: as a setpoint control, as a fail alarm, or as a HI-LO alarm band. The three settings for Rly A Mode are **CON**, **FAIL** and **AL**.
- The **CON** setting enables normal control operation for Relay A, with settings for setpoint, hysteresis, delay and phasing appearing in the CONFIG menu automatically. See Figure 25 - Control Relay Example
- for further details.
- The **FAIL** setting enables the fail alarm mode for Relay A. Relay A will then trip on any condition that causes the FAIL icon to be displayed on the LCD. Using this mode allows the User to send alarm indications to other remote devices.

The **AL** setting allows two setpoints to be selected for the same relay, producing a HI-LO alarm band. In this mode, Relay A will trip inside or outside of the band, depending upon the Phase selected. See Figure 26 - Alarm Relay Example

for further details.

Relay B Mode Relay C Mode

Relay B and C can be used in two ways: as a setpoint control, or as an alarm. The two settings for Relay B Mode are **CON** and **FAIL**.

The **CON** setting enables normal setpoint operation for Relay B/C. Relay B/C then operates identically to Relay A, with settings for setpoint, hysteresis, delay and phasing appearing in the CONFIG menu automatically. See Figure 25 for details.

The **FAIL** setting enables the fail alarm mode for Relay B/C. Relay B/C will then trip on any condition that causes the FAIL icon to be displayed on the LCD. Note that the Relay C indicator shows up only on the lower screen of the display next to the temperature reading. This is because the default setting for relay C is the **FAIL** setting. Using this mode allows the User to send alarm indications to other remote devices. See Figure 26 for details.

***Relay D Mode *Relay E Mode *Relay F Mode**

OPTIONAL. Relays D, E, and F can be used in two ways: as a setpoint control, or as an alarm. The two settings for Relay B Mode are **CON** and **FAIL**.

The **CON** setting enables normal setpoint operation for Relay B. Relay B then operates identically to Relay A, with settings for setpoint, hysteresis, delay and phasing appearing in the CONFIG menu automatically. See Figure 25 for details.

Temp Units

This function sets the display units for temperature measurement. Press ENTER to initiate user entry mode, and the entire value will flash. Use the UP arrow key to modify the desired display value. The choices are °F and °C. Press ENTER to store the new value.

5.25 Control Menu

The Control Menu contains all of the output control user settings:

Set PID 0%

Set PID 100%

[lout1=PID]

If the PID is enabled, this function sets the minimum and maximum controller end points. Unlike the standard 4-20 mA output, the controller does not “scale” output values across the endpoints. Rather, the endpoints determine where the controller would normally force minimum or maximum output in an attempt to recover the setpoint (even though the controller can achieve 0% or 100% anywhere within the range.)

If the 0% point is lower than the 100% point, then the controller action will be “reverse” acting. That is, the output of the controller will increase if the measured value is less than the setpoint, and the output will decrease if the measured value is larger than the setpoint. Flipping the stored values in these points will reverse the action of the controller to “direct” mode.

The entry value is limited to a value within the range specified in “Set Range”, and the 0% and the 100% point must be separated by at least 1% of this range. Use the LEFT arrow key to select the first digit to be modified. Then use the UP and LEFT arrow keys to select the desired numerical value. Press ENTER to store the new value.

PID Setpnt

[lout1=PID]

The measured value which the controller is attempting to maintain by adjusting output value. It is the nature of the PID controller that it never actually gets to the exact value and stops. The controller is continually making smaller and smaller adjustments as the measured value gets near the setpoint.

PID Prop

[lout1=PID]

Proportional gain factor. The proportional gain value is a multiplier on the controller error (difference between measured value and setpoint value.) Increasing this value will make the controller more responsive.

PID Int

[lout1=PID]

Integral is the number of “repeats-per-minute” of the action of the controller. It is the number of times per minute that the controller acts on the input error. At a setting of 2.0 rpm, there are two repeats every minute. If the integral is set to zero, a fixed offset value is added to the controller (manual reset.) Increasing this value will make the controller more responsive.

PID Deriv

[lout1=PID]

Derivative is a second order implementation of Integral, used to suppress “second-order” effects from process variables. These variables may include items like pumps or mixers that may have minor impacts on the measured value. The derivative factor is rarely used and therefore it is best in most cases to leave it at the default value. Increasing this value will make the controller more responsive.

Set 4 mA (#1)**Set 20 mA (#1)**

These functions set the main 4 and 20 mA current loop output points for the transmitter. The units displayed depend on the selection made in the CONFIG menu for lout #1 Mode. Typically, lout #1 is used for concentration.

The value stored for the 4 mA point may be higher or lower than the value stored for the 20 mA point. The entry values are limited to values separated by at least 1% of the range. Use the LEFT arrow key to select the first digit to be modified. Then use the UP and LEFT arrow keys to select the desired numerical value. Press ENTER to store the new value.

Set 4 mA (#2)**Set 20 mA (#2)**

[temp/conductivity]

These functions set the second 4 mA and 20 mA current loop output points for the transmitter. The output may be set to track temperature (default), or conductivity. The values stored for the 4 mA point may be higher or lower than the value stored for the 20 mA point.

The entry value is limited to a value between 0 and 110°C if it is set for temperature, within the range specified in “Set Range” if the output is set to track conductivity. The 4 mA and the 20 mA point must be at least 20 units away from each other. Press ENTER to initiate user entry mode, and the value will flash. Use arrow keys to modify value. Press ENTER to store the new value.

***Set 4 mA #3**

***Set 20 mA #3**

[temp/uS/TDS]

OPTIONAL These functions set the optional third 4 mA and 20 mA current loop output points for the analyzer. The output may be set to track temperature (default), conductivity, or TDS. The values stored for the 4 mA point may be higher or lower than the value stored for the 20 mA point.

The range is between 0 and 110°C if it is set for temperature, within the range specified in “Set Range” if the output is set to track conductivity, and must be within the display range established by the conductivity range if set to track TDS. The 4 mA and the 20 mA point must be at least 20 units away from each other. Press ENTER to initiate user entry mode, and the value will flash. Use arrow keys to modify value. Press ENTER to store the new value.

***A Setpoint**

This function establishes the conductivity trip point for relay A. The entry value is limited to a value within the range specified in “Set Range”. Use the LEFT arrow key to select the first digit to be modified. Then use the UP and LEFT arrow keys to select the desired numerical value. Press ENTER to store the new value.

***A Hysteresis**

This function establishes the hysteresis, or “deadband”, for Relay A. Hysteresis is most often used to control relay chattering; however, it may also be used in control schemes to separate the ON/OFF trip points of the relay. Press ENTER to initiate user entry mode, and the value will flash. Use the arrow keys to modify value. Press ENTER to store the new value.

***A Delay**

This function places an additional amount of time delay on the trip point for relay A. This delay is in addition to the main delay setting for the controller. The entry value is limited to a value between 0 and 999 seconds. Press ENTER to initiate user entry mode, and the value will flash. Use arrow keys to modify value; range is 0 to 999 seconds. Press ENTER to store the new value.

***A Phasing**

This function establishes the direction of the relay trip. When phase is HI, the relay operates in a direct mode. Therefore, the relay energizes and the LCD indicator illuminates when the conductivity value **exceeds** the setpoint. When the phase is LO, the relay energizes and the LCD indicator illuminates when the conductivity level drops **below** the setpoint. The failsafe setting does have an impact on this logic. The description here assumes the failsafe setting is OFF. Press ENTER to initiate user entry mode, and the entire value will flash. Use the UP arrow key to modify the desired value; selections include **HI** for direct operation or **LO** for reverse operation. Press ENTER to store the new value.

See Figure 25 - Control Relay Example below for a visual description of a typical control relay application.

When value rises to ≥ 1.000 mS, relay closes.

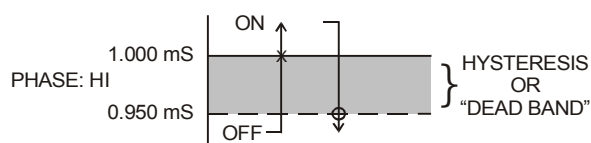

When value falls to ≤ 1.000 mS, relay opens.

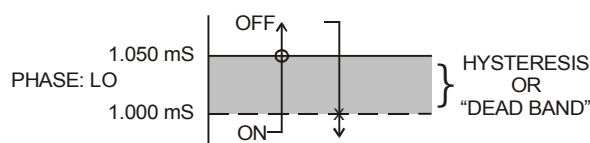

When value rises to ≤ 1.000 mS, relay opens.

When value falls to ≥ 1.000 mS, relay closes.

Settings:

Setpoint:	1.000 μ S	Hyst:	0.050
Delay:	000	Failsafe:	OFF

Figure 25 - Control Relay Example

- *Setpnt A-HI
- *Hyst A-HI
- *Delay A-HI
- *Setpnt A-LO
- *Hyst A-LO
- *Delay A-LO

If Relay A Mode is set to Alarm Mode, **AL**, then the following settings will appear in the Config Menu list automatically. In this mode, two setpoints can be selected on the same relay, to create an alarm band. Phase HI selection causes the relay to energize outside of the band, and Phase LO causes the relay to energize inside of the band. This feature enables one relay to be used as a control relay while the other is used as a HI-LO Alarm relay at the same time. Setpoint A-LO must be set lower than Setpoint A-HI. When AL mode is first selected, Setpoint A-LO is defaulted to 0.

Figure 26 - Alarm Relay Example
is a visual description of a typical alarm relay application.

When value rises to ≥ 1.000 mS, relay closes, until value falls back to ≤ 0.950 mS.

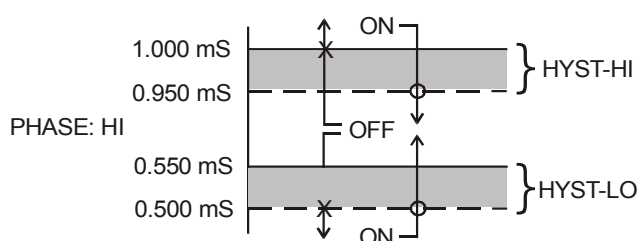

When value falls to ≤ 0.500 mS, relay closes, until value rises back to ≥ 0.550 mS.

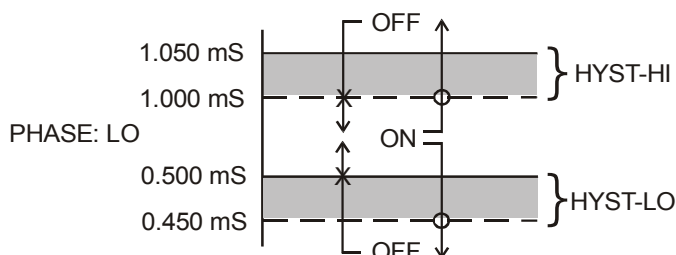

When value falls to ≤ 1.000 mS, relay closes, until value rises back to ≥ 1.050 mS.

When value rises to ≥ 0.500 mS, relay closes, until value falls back to ≤ 0.450 mS.

Settings:

SetpointA-HI:	1.000 mS	Setpoint A-LO:	0.500 mS
Hyst A-HI:	0.050	Hyst A-LO:	0.05
Delay A-HI:	000	Delay A-LO:	000

Figure 26 - Alarm Relay Example

- *B Setpoint
- *B Hysteresis
- *B Delay
- *B Phasing

If Relay B Mode is set to **CON** (see **Relay B Mode**), then Relay B will function identically to Relay A. Relay B settings appear in the CONFIG menu list automatically.

C Setpoint
C Hysteresis
C Delay
C Phasing

If Relay C Mode is set to **CON** (see **Relay C Mode**), then Relay C will function identically to Relay A. Relay C settings appear in the CONFIG menu list automatically.

D,E,F Setpoint
D,E,F Hyster
D,E,F Delay
D,E,F Phasing

If optional Relay D, E, or F Mode is set to **CON** (see **Relay D,E,F Modes**), then the Relay will function identically to Relay A. Relay settings appear in the CONFIG menu list automatically.

5.26 Diagnostics Menu [DIAG]

The diagnostics menu contains all of the user settings that are specific to the system diagnostic functions, as well as functions that aid in troubleshooting application problems.

Set Hold

The Set Hold function locks the current loop output values on the present process value, and halts operation of the PID controller. This function can be used prior to calibration, or when removing the sensor from the process, to hold the output in a known state. Once HOLD is released, the outputs return to their normal state of following the process input. The transfer out of HOLD is bumpless on the both analog outputs - that is, the transfer occurs in a smooth manner rather than as an abrupt change. An icon on the display indicates the HOLD state, and the HOLD state is retained even if power is cycled. Press ENTER to initiate user entry mode, and entire value will flash. Use the UP arrow key to modify the desired value, selections are **ON** for engaging the HOLD function, and **OFF** to disengage the function. Press ENTER to store the new value. Note - the Set Hold function holds BOTH current levels, as well as ALL relay settings.

The Set Hold function can also hold at an output value specified by the user. To customize the hold value, first turn the HOLD function on. Press the ESC key to go to the DIAG Menu and scroll to Sim Output using the UP arrow key. Press ENTER. Follow the instructions under Sim Output (see following page).

CAUTION: There is no time-out on the hold feature. Once placed into hold mode, return to normal operation must be done manually.

Fault List

The Fault List screen is a read-only screen that allows the user to display the cause of the highest priority failure. The screen indicates the number of faults present in the system and a message detailing the highest priority fault present. Note that some faults can result in multiple displayed failures due to the high number of internal tests occurring. As faults are corrected, they are immediately cleared.

Faults are not stored; therefore, they are immediately removed if power is cycled. If the problem causing the faults still exists, however, faults will be displayed again after power is re-applied and a period of time elapses during which the diagnostic system re-detects them. The exception to this rule is the calibration failure. When a calibration fails, no corrupt data is stored. Therefore, the system continues to function normally on the data that was present before the calibration was attempted.

After 30 minutes or if power to the analyzer is cycled, the failure for calibration will be cleared until calibration is attempted again. If the problem still exists, the calibration failure will re-occur. Press ENTER to initiate view of the highest priority failure. The display will automatically return to normal after a few seconds.

PID Timer

This function sets a timer to monitor the amount of time the PID controller remains at 0% or 100%. This function only appears if the PID controller is enabled. If the timer is set to 0000, the feature is effectively disabled. If the timer value is set to any number other zero, a FAIL condition will occur if the PID controller remains at 0% or 100% for the timer value. If one of the relays is set to FAIL mode, this failure condition can be signaled by a changing relay contact.

Press ENTER to initiate user entry mode, and the entire value will flash. Use the UP arrow key to modify desired value; range of value is 0-9999 seconds. Press ENTER to store the new value.

Sim Out

The Sim Out function allows the user to simulate the chlorine level of the instrument in the user selected display range. The user enters a ppm value directly onto the screen, and the output responds as if it were actually receiving the signal from the sensor. This allows the user to check the function of attached monitoring equipment during set-up or troubleshooting. Escaping this screen returns the unit to normal operation. Press ENTER to initiate the user entry mode, and the right-most digit of the value will flash. Use arrow keys to modify desired value.

The starting display value in SIM mode will be the last read value of the input. The output will be under control of the SIM screen until the ESC key is pressed. The instrument will automatically terminate the simulated output after 30 minutes and return to normal operation unless the "HOLD" function is engaged.

Note: If the HOLD function is engaged before the Sim Output function is engaged, the simulated output will remain the same even when the ESC key is pressed. Disengage the HOLD function to return to normal output.

Fail Out #1

This function enables the user to define a specified value that the main current output will go to under fault conditions. When enabled to **ON**, the output may be forced to the current value set in **Fail Val** (next item.) With the Fail Out setting of ON, and a Fail Val setting of 6.5 mA, any alarm condition will cause the current loop output to drop outside the normal operating range to exactly 6.5 mA, indicating a system failure that requires attention.

Press ENTER to initiate user entry mode, and the entire value will flash. Use the UP arrow key to modify desired value; selections are **ON**, **OFF**. Press ENTER to store the new value.

Fail Val #1 Sets the output failure value for lout#1. When **Fail Out** above is set to **ON**, this function sets value of the current loop under a FAIL condition. The output may be forced to any current value between 4-20 mA.

Press ENTER to initiate user entry mode, and the entire value will flash. Use the UP arrow key to modify desired value; selections are between **4mA**, and **20mA**. Press ENTER to store the new value.

Fail Val #2 This function sets the value of current loop output #2 under a FAIL condition. The settings and operation are identical to Fail Out for output #1.

***Fail Out #3** **OPTIONAL.** This function sets the fail-mode of current loop output #3 under a FAIL condition. The settings and operation are identical to Fail Out for output #1.

***Fail Val #3** **OPTIONAL.** This function sets the value of current loop output #3 under a FAIL condition. The settings and operation are identical to Fail Out for output #1.

Backlight This function has three options. **ON** – On all the time, **OFF** – Off all the time, **AL** – Alarm (Default). This function flashes the backlight on and off whenever the Fail icon is displayed.

Failsafe This function allows the user to set the optional system relays to a failsafe condition. In a failsafe condition, the relay logic is reversed so that the relay is electrically energized in a normal operating state. By doing this, the relay will not only change state when, for example, a chlorine limit is exceeded, but also when power is lost to the controller.

When failsafe is selected to be ON, the normally-open contacts of the relay will be closed during normal operation. In an attempt to make this configuration less confusing, the LCD icon logic is reversed with this setting, and the icon is OFF under this normal condition. Therefore, when the trip condition occurs, the closed N.O. contacts will be opened (relay de-energized), and the LCD icon will illuminate. In addition, a power fail would also cause the contacts to open.

Start Delay

This function is designed to minimize control or alarm issues arising from temporary power loss. When power goes down, the monitor records the analog output values and the status of relays and PID functions. When power is restored, the analog values and relays will be held at the pre-power loss values for a defined period of time. This “start delay” may be programmed for periods from 0-9.9 minutes. This function is set to 0.0 minutes by default and must be activated by the user if desired by setting a positive time value

Set Default

The Set Default function allows the user to return the instrument back to factory default data for all user settings or for just the calibration default. It is intended to be used as a last resort troubleshooting procedure. All user settings or the calibration settings are returned to the original factory values. Hidden factory calibration data remains unchanged. Press ENTER to initiate user entry mode and select either All or CAL with the UP arrow key.

Part 6 – Calibration

6.1 Overview and Methods

Calibration of the Q46C4 is required to accurately match the sensor characteristics to the monitor/analyzer. Since the output of the conductivity sensor does not degrade over time, it is typically only required that the sensor be calibrated at initial installation and then cleaned periodically to maintain proper system accuracy.

It is important for the user to establish a periodic cleaning and calibration-check schedule for sensor maintenance to maintain high system accuracy. Since the conductivity of a solution is greatly affected by temperature, proper settings for thermal compensation are critical for accurate operation. Before calibrating the instrument for the very first time, it is important to select the proper operating parameters in the configuration menus for temperature compensation methods.

When using conductivity calibration standards for a wet calibration, take care not to inadvertently contaminate the reference solution; always thoroughly clean the sensor, rinsing off in tap water, and then finish rinsing in pure or de-ionized water. In addition, note that calibration solutions less than 200 μ S or greater than 100 mS can be very unstable. Moving the sensor back and forth between different value conductivity reference solutions can quickly contaminate the solutions and render them inaccurate.

6.11 1-Point Cal Explained

The 1-point calibration method is generally known as the "grab sample" calibration method. In the 1-point calibration method, the sensor may be removed from the application and placed into a reference solution. It may also be left in the measurement process and calibrated by reference. The 1-point calibration adjusts the sensor slope to match the exact calibration point. Readings beyond that point are then extrapolated from the determined slope of the calibration line. Since the sensor slope does not degrade over time, frequent re-calibration is unnecessary. Calibration accuracy can be optimized by calibrating with a reference solution which is close to the values typically measured.

6.12 Zero Cal Explained

The sensor offset must be set for the system only on initial sensor installation, or when the cable length has been altered. The Zero Cal method establishes each of the sensor offset points for the instrument's 6 ranges of operation.

6.2 Performing Sensor Zero Cal

The sensor offset **MUST** be set for the system on initial sensor installation, or when the cable length has been altered. However, it can easily be adjusted at any time by re-calibrating the sensor in air. The sensor zero-calibration generally has little effect in measurements above about 50 mS, but it can have a significant effect in measurements below about 1 mS. If the sensor zero cal is to be performed, it must be done **BEFORE** the 1-point reference calibration.

To begin the sensor zero cal, verify that the sensor is connected and clean and dry. It should be placed in the air with the electrodes at least 1 foot away from any nearby objects. Holding it is not recommended – place on table or just hang.

Procedure

1. Remove sensor from process and clean thoroughly. Dry sensor and position on table or hang in air (in air is best.) If on table, let end of sensor hang over edge of table.
2. Scroll to the CAL menu section using the MENU key and press ENTER or the UP arrow key. Scroll to the menu **Zero Cal**.
3. Press the ENTER key. The screen will prompt the user to position the sensor in air.
4. Press the ENTER key. The screen will automatically scroll through all ranges and establish and store the proper zero points.

6.3 Performing 1-Point Cal

This calibration method is intended to be used as an on-line calibration method or a wet-cal with reference solutions. During calibration, the system will display the current conductivity reading, and the user can manually enter a reference value from a reference solution bottle or a comparative reference instrument.

For wet calibrations, the user may use pre-made calibration references (also available from ATI) or a NaCl solution may be made using pure, dried NaCl crystals and one liter of high purity, de-ionized, CO₂-free water as mixed in the table shown in Figure 27 - NaCl Reference Solution Calibration Chart

. All table data is at 25°C therefore, the sensor must be at this temperature to calibrate properly using the table data. If another reference calibration solution is being used, be sure to note temperature of reference solution before calibration. Since the sensor must ideally be at the specified temperature, wet calibrations can be difficult to perform accurately.

NaCl Reference Solution for Calibration (25°C)	
µS/cm	NaCl (gm)
100	0.05
200	0.10
500	0.25
1000	0.50
2000	1.01
3000	1.53
4000	2.06
5000	2.61
8000	4.34
10000	5.56
20000	11.59

Figure 27 - NaCl Reference Solution Calibration Chart

During the 1-point calibration, the system will automatically pick the correct range for the calibration reference if the Q46C4 is in the **AUTO** range. If the Q46C4 is in a normal display mode, the user must be careful to calibrate with a solution that falls into the manual range selected. If the calibration solution is outside the manual range, an error will result.

Procedure

1. If a zero calibration on the sensor is also to be performed, that must be done **FIRST**. The zero calibration process can have an impact on the result of the 1-point calibration. So if a zero cal is required, do that procedure and return here.
2. Determine whether the calibration will be done on-line or with the sensor removed and placed into a reference solution. If the sensor is removed from the application, rinse and clean.
3. If the sensor has been removed and placed into a solution, allow the sensor to temperature equilibrate with the solution as much as possible. With the sensor coming from an application that differs greatly in temperature, the user may have to wait as much as 20 minutes. If the sensor is on-line, the user may want to set the output HOLD feature prior to calibration to lock out any output fluctuations.
4. Scroll to the CAL menu section using the MENU key and press ENTER or the UP arrow key. Scroll until **Cal Cond** is displayed. Press ENTER.
5. The screen will prompt the user to place the sensor into the reference solution (ideally this has already been done to achieve temperature equilibrium.) Once sensor is ready, press ENTER.
6. The system now begins acquiring data for the calibration value. As data is gathered, the units for conductivity and temperature may flash. Flashing units indicate that this parameter is unstable. The calibration data point acquisition will stop only when the data remains stable for a pre-determined amount of time. This can be overridden by pressing ENTER. If the data remains unstable for 10 minutes, the calibration will fail and the message **Cal Unstable** will be displayed.
7. The screen will display the last measured conductivity value and a message will be displayed prompting the user for the reference value. The user must then modify the screen value with the arrow keys and press ENTER. The system then performs the proper checks.
8. If accepted, the screen will display the message **PASS** with the slope value, then it will return to the main measurement display. If the calibration fails, a message indicating the cause of the failure will be displayed and the FAIL icon will be turned on.

6.4 Temperature Calibration

The temperature input is factory calibrated for the highest accuracy. Temperature calibration is not recommended; however, it is provided for applications in which very long cable lengths are needed. For example, at 50 feet, readings may be off $\pm 0.2^{\circ}\text{C}$. The temperature calibration sequence is essentially a 1-point offset calibration that allows adjustments of approximately $\pm 5^{\circ}\text{C}$.

The sensor temperature may be calibrated on line, or the sensor can be removed from the process and placed into a known solution temperature reference. In any case, it is critical that the sensor be allowed to reach temperature equilibrium with the solution in order to provide the highest accuracy. When moving the sensor between widely different temperature conditions, it may be necessary to allow as much as one hour before the calibration sequence is initiated. If the sensor is on-line, the user may want to set the output HOLD (see Section 5.26) feature prior to calibration to lock out any output fluctuations.

Procedure

1. Scroll to the CAL menu section using the MENU key and press ENTER or the UP arrow key.
2. Press the UP arrow key until **Cal Temp** is displayed.
3. Press the ENTER key. The message **Place sensor in solution then press ENTER** will be displayed. Move the sensor into the calibration reference (if it hasn't been moved already) and wait for temperature equilibrium to be achieved. Press ENTER to begin the calibration sequence.
4. The calibration data gathering process will begin. The message **Wait** will flash as data is accumulated and analyzed. The $^{\circ}\text{C}$ or $^{\circ}\text{F}$ symbol may flash periodically if the reading is too unstable.
5. The message **Adjust temp value then press ENTER** will be displayed, and the right-most digit will begin to flash, indicating that the value can be modified. Using the UP and LEFT arrow keys, modify the value to the known ref solution temperature. Adjustments up to $\pm 5^{\circ}\text{C}$ from the factory calibrated temperature are allowed. Press ENTER.
6. Once completed, the display will indicate **PASS** or **FAIL**. If the unit fails, the temperature adjustment may be out of range, the sensor may not have achieved complete temperature equilibrium, or there may be a problem with the temperature element. In the event of calibration failure, it is recommended to attempt the calibration again immediately.

Part 7 – PID Controller Details

7.1 PID Description

PID control, like many other control schemes, are used in chemical control to improve the efficiency of chemical addition or control. By properly tuning the control loop that controls chemical addition, only the amount of chemical that is truly required is added to the system, saving money. The savings can be substantial when compared to a system which may be simply adding chemical at a constant rate to maintain some minimal addition under even the worst case conditions. The PID output controller is highly advantageous over simple control schemes that just utilize direct (proportional only) 4-20 mA output connections for control, since the PID controller can automatically adjust the “rate” of recovery based on the error between the setpoint and the measured value – which can be a substantial efficiency improvement..

The PID controller is basically designed to provide a “servo” action on the 4-20 mA output to control a process. If the user requires that a measured process stay as close as possible to a specific setpoint value, the controller output will change from 0% to 100% in an effort to keep the process at the setpoint. To affect this control, the controller must be used with properly selected control elements (valves, proper chemicals, etc.) that enable the controller to add or subtract chemical rapidly enough. This is not only specific to pumps and valves, but also to line sizes, delays in the system, etc.

This section is included to give a brief description of tuning details for the PID controller, and is not intended to be an exhaustive analysis of the complexities of PID loop tuning. Numerous sources are available for specialized methods of tuning that are appropriate for a specific application.

7.2 PID Algorithm

As most users of PID controllers realize, the terminology for the actual algorithm terms and even the algorithms themselves can vary between different manufacturers. This is important to recognize as early as possible, since just plugging in similar values from one controller into another can result in dramatically different results. There are various basic forms of PID algorithms that are commonly seen, and the implementation here is the most common version; The ISA algorithm (commonly referred to as the “ideal” algorithm.)

$$\text{output} = P \left[e(t) + \frac{1}{I} \int e(t) dt + D \frac{de(t)}{dt} \right]$$

Where:

output =	controller output
P =	proportional gain
I =	integral gain
D =	derivative gain
t =	time
e(t) =	controller error (e=measured variable – setpoint)

Figure 28 - PID Equation

The most notable feature of the algorithm is the fact the proportional gain term affects all components directly (unlike some other algorithms - like the “series” form.) If a pre-existing controller utilizes the same form of the algorithm shown above, it is likely similar settings can for made if the units on the settings are exactly the same. Be careful of this, as many times the units are the reciprocals of each other (i.e. reps-per-min, sec-per-rep.)

PID stands for “proportional, integral, derivative.” These terms describe the three elements of the complete controller action, and each contributes a specific reaction in the control process. The PID controller is designed to be primarily used in a “closed-loop” control scheme, where the output of the controller directly affects the input through some control device, such as a pump, valve, etc.

Although the three components of the PID are described in the setting area (section 4.25), here are more general descriptions of what each of the PID elements contribute to the overall action of the controller.

P Proportional gain. With no “I” or “D” contribution, the controller output is simply a factor of the proportional gain multiplied by the input error (difference between the measured input and the controller setpoint.) Because a typical chemical control loop cannot react instantaneously to a correction signal, proportional gain is typically not efficient by itself – it must be combined with some integral action to be useful. Set the P term to a number between 2-4 to start. Higher numbers will cause the controller action to be quicker.

- I Integral gain. Integral gain is what allows the controller to eventually drive the input error to zero – providing accuracy to the control loop. It must be used to affect the accuracy in the servo action of the controller. Like proportional gain, increasing integral gain results in the control action happening quicker. Set the I term to a number between 3-5 to start (1-2 more than P). Like proportional gain, increasing the integral term will cause the controller action to be quicker.

- D Derivative gain. The addition of derivative control can be problematic in many applications, because it greatly contributes to oscillatory behavior. In inherently slow chemical control process', differential control is generally added in very small amounts to suppress erratic actions in the process that are non-continuous, such as pumps and valves clicking on and off. However, as a starting point for chemical process control, its best to leave the "D" term set to 0.

Based on these descriptions, the focus on tuning for chemical applications really only involves adjustment of "P" and "I" in most cases. However, increasing both increases the response of the controller. The difference is in the time of recovery. Although combinations of high "P's" and low "I" will appear to operate the same as combinations of low "P's" and high "I's", there will be a difference in rate of recovery and stability. Because of the way the algorithm is structured, large "P's" can have a larger impact to instability, because the proportional gain term impacts all the other terms directly. Therefore, keep proportional gain lower to start and increase integral gain to achieve the effect required.

Many of the classical tuning techniques have the user start with all values at 0, and then increase the P term until oscillations occur. The P value is then reduced to ½ of the oscillatory value, and the I term is increased to give the desired response. This can be done with the Q46 controller, with the exception that the I term should start no lower than 1.0.

If it appears that even large amounts of integral gain (>20) don't appreciably increase the desired response, drop I back to about 1.0, and increase P by 1.00, and start increasing I again. In most chemical control schemes, I will be approximately 3 times the value of P.

7.3 Classical PID Tuning

Unlike many high speed position applications where PID loops are commonly used, the chemical feed application employed by this instrument does not require intense mathematical exercise to determine tuning parameters for the PID. In fact, the risk of instability is far greater with overly tuned PID control schemes. In addition, many of the classical mathematical exercises can be damaging or wasteful in the use of chemicals when the process is bumped with large amounts of input error to seek a response curve. Because of this, the general adjustment guidelines described in section 7.2 are sufficient for almost all application tuning for this instrument. Beyond this, many sources are available for classical tuning methods.

7.4 Manual PID Override Control

The Q46 PID output function allows the user to take manual control of the PID control signal. This is often useful when starting up a control loop, or in the event that you wish to bump the system manually to measure system response time.

To access the manual PID control, you must be in the MEASURE mode of operation and you must have the PID output displayed on the lower line. This line will indicate “XX.X% XX.X mA” with the X values simply indicating the current values. With this display on the screen, press and hold the ENTER key for about 5 seconds. You will see a small “m” show up between the % value and the mA value. This indicates you are now in manual mode.

Once in manual, you may increase the PID output by pressing the UP arrow or you may decrease the output by pressing the LEFT arrow. This will allow you to drive the PID output to any desired setting.

To revert to normal PID control, press and hold the ENTER key again until the “m” indicator disappears.

7.5 Common PID Pitfalls

The most common problem occurring in PID control applications involves the false belief that proper settings on only the PID controller can balance any process to an efficient level.

Close-loop control can only be effective if all elements in the loop are properly selected for the application, and the process behavior is properly understood. Luckily, the nature of simple chemical control process' are generally slow in nature. Therefore, even a de-tuned controller (one that responds somewhat slowly) can still provide substantial improvements to setpoint control. In fact, damaging oscillatory behavior is far more likely in tightly tuned controllers where the user attempted to increase response too much.

When deciding on a PID control scheme, it is important to initially review all elements of the process. Sticking valves, undersized pumps, or delays in reaction times associated with chemical addition can have a dramatic effect on the stability of the control loop. When controlling a chemical mix or reaction, the sensor should be placed in a location that ensures proper mixing or reaction time has occurred.

The easiest processes to control with closed-loop schemes are generally linear, and symmetrical, in nature. For example, controlling level in tank where the opening of valve for a fixed period of time corresponds linearly to the amount that flows into a tank. Chemical control process' can be more problematic when the nature of the setpoint value is non-linear relative to the input of chemical added. For example, pH control of a process may appear linear only in a certain range of operation, and become highly exponential at the extreme ranges of the measuring scale. In addition, if a chemical process is not symmetrical, that means it responds differentially to the addition and subtraction of chemical. It is important in these applications to study steady-state impact as well as step-change impact to process changes. In other words, once the process has apparently been tuned under normal operating conditions, the user should attempt to force a dramatic change to the input to study how the output reacts. If this is difficult to do with the actual process input (the recommended method), the user can place the control in manual at an extreme control point such as 5% or 95%, and release it in manual. The recovery should not be overly oscillatory. If so, the loop needs to be de-tuned to deal with that condition (reduce P and/or I.)

Part 8 – System Maintenance



8.1 System Checks

1. If the FAIL icon is flashing on the display, check the Fault List to determine the cause of the failure. To access the Fault List, press the MENU/ESC key until the DIAG menu appears. Then press the UP arrow key until the Fault List appears. Press the ENTER key to access the Fault List, and the highest priority fault message will be displayed. For a list of all messages and possible causes/solutions, refer to Section 8.5.
2. In **ALL** environments, connect an earth ground jumper to earth terminal connection on transmitter.
3. Perform a one-point calibration prior to sensor installation.
4. Check sensor cable color to terminal strip markings.
5. For highly unstable behavior, remove sensor from the process and measure the process solution in a plastic beaker. If the reading now stabilizes, place wire in beaker solution and actual process solution to determine if a ground loop exists.
6. If the instrument 4-20 mA output is connected into other control systems, disconnect output loop from system load and run through a handheld DMM to monitor current. Verify that the system operates correctly in this mode first.

8.2 Instrument Checks

1. Remove sensor completely and connect 1100 Ohms from the yellow to black sensor input leads. Make sure the unit is configured for a Pt1000 thermal element and that the temperature is not in manual locked mode. The temperature reading should display approximately 25 °C and the conductivity reading should display approximately 0.0 uS.
2. With a DMM, measure the DC voltage from the white sensor lead connection to the black sensor lead connection. With the positive DMM lead on the white wire, the meter should read between -4.5 and -5.5 VDC.

3. For the line powered version, verify the proper line voltage power. With power disconnected, verify continuity across the line fuse.

8.3 Cleaning the Sensor

Keep the sensor as clean as possible for optimum measurement accuracy. Frequency of cleaning depends upon the process solution.

Wipe the measuring end of the sensor with a fine abrasive cloth (i.e. ScotchBrite of equiv.). Then rinse with clean water (distilled or de-ionized if possible). This should remove most contaminate buildup.

If necessary, soak the sensor for several minutes in a mild soap solution. Use a small, extra-soft bristle brush (such as a mushroom brush) to thoroughly clean the electrode surfaces. If surface deposits are not completely removed after performing this step, a dilute acid may be used to dissolve the deposits. Soak for a few minutes, and then rinse the sensor thoroughly with clean water (distilled or de-ionized if possible).

Note: DO NOT soak the sensor in dilute acid solution for more than 5 minutes.



WARNING: ACIDS ARE HAZARDOUS. Always wear eye and skin protection when handling. Follow all Material Safety Data Sheet recommendations. A hazardous chemical reaction can be created when certain acids come in contact with process chemicals. Make this determination before cleaning with any acid, regardless of concentration. **DO NOT** use Hydrochloric Acid on any stainless steel portion of the sensor.

After cleaning the sensor, check measurement and re-calibrate the sensor.

8.4 Troubleshooting

The first step in resolving any measurement problem is to determine whether the trouble lies in the sensor or the transmitter. Since measurement problems can often be traced to foulants coating the electrodes, cleaning the sensor using the method outlined in Section 9.3 should always be the first step in any troubleshooting.

If the sensor cannot be calibrated after cleaning, perform the following test. A multimeter will be needed.

1. Disconnect the sensor from the transmitter or junction box.
2. Using a multimeter, verify continuity between electrodes indicated below and the corresponding wire colors in the cable (red, blue, green and white, only).

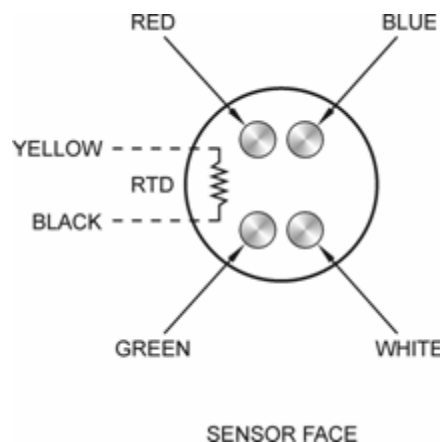

3. Verify that the sensor's temperature element (Pt1000 RTD) is functioning properly by measuring the resistance between the sensor's yellow and black wires. The nominal resistance value at 25 °C is 1097 ohms. Use the following table as a guide to the approximate resistance value:

°C	RTD Ω
20	1078
25	1097
30	1117
35	1136

8.5 Display Messages

The Q46 Series instruments provide a number of diagnostic messages that indicate problems during normal operation and calibration. These messages appear as prompts on the secondary line of the display or as items on the Fault List.

The following messages will appear as prompts:

MESSAGE	DESCRIPTION	POSSIBLE CORRECTION
Max is 200	Entry failed, maximum value allowed is 200.	Reduce value to ≤ 200
Min is 200	Entry failed, minimum value allowed is 200.	Increase value to ≥ 200
Cal Unstable	Calibration problem, data too unstable to calibrate.	Clean sensor, get fresh cal solutions, allow temperature and conductivity readings to fully stabilize, do not handle sensor or cable during calibration.
Slope HIGH	Sensor slope from calibration is greater than 110%.	Get fresh cal solutions, allow temperature and conductivity readings to fully stabilize, check for correct buffer values
Slope LOW	Sensor slope from calibration is less than 80%.	Clean sensor, get fresh cal solutions, allow temperature and conductivity readings to fully stabilize, check for correct buffer values.
Offset HIGH	Sensor offset from calibration is less than -90 mV or greater than $+90$ mV	Clean or replace saltbridge, replace reference cell solution, clean sensor, get fresh cal solutions, allow temperature and conductivity readings to fully stabilize, check for correct buffer values.
Out of Range	Input value is outside selected range of the specific list item being configured.	Check manual for limits of the function to be configured.
Locked!	Transmitter security setting is locked.	Enter security code to allow modifications to settings.
Unlocked!	Transmitter security has just been unlocked.	Displayed just after security code has been entered.
TC-F25 lock!	The TC selection is in F25 mode, locked at 25 °C	Calibration and TC adjustment cannot be performed while the TC is in F25 mode. To allow access to TC calibrations, change TC mode from F25 (fixed 25) to SENS (sensor).

The following messages will appear as items on the Fault List:

MESSAGE	DESCRIPTION	POSSIBLE CORRECTION
Sensor High	The raw signal from the sensor is too high.	Check wiring connections to sensor.
Sensor Low	The raw signal from the sensor is too low.	Check wiring connections to sensor.
Cond too High	The conductivity reading is > 2000 mS.	The conductivity reading is over operating limits.
Temp High	The temperature reading is > 210 °C.	The temperature reading is over operating limits. Check wiring and expected temp level. Perform RTD test as described in sensor manual. Recalibrate sensor temperature element if necessary.
Temp Low	The temperature reading is < -10 °C	The temperature reading is under operating limits. Check wiring and expected temp level. Perform RTD test as described in sensor manual. Recalibrate sensor temperature element if necessary.
TC Error	TC may be open or shorted.	Check sensor wiring and perform RTD test as described in sensor manual.
Clean Sensor	Foulants on sensor have reached the level that they cannot be adjusted out.	Clean the sensor thoroughly.
Cond Cal Fail	Failure of conductivity calibration.	Clean sensor, get fresh cal solutions and redo calibration. If still failure, sensor slope may be less than 50%. Perform sensor tests as described in sensor manual. Replace sensor if still failure.

MESSAGE	DESCRIPTION	POSSIBLE CORRECTION
Cond Cal Fail	Failure of conductivity calibration.	Clean sensor, get fresh cal solutions and redo calibration. If still failure, sensor slope may be less than 50%. Perform sensor tests as described in sensor manual. Replace sensor if still failure.
TC Cal Fail	Failure of temperature calibration.	Clean sensor, check cal solution temperature and repeat sensor temp calibration. TC calibration function only allows adjustments of +/- 6 °C. If still failure, perform sensor tests as described in sensor manual. Replace sensor if still failure. Note that TC offset may also be adjusted using the Cal TC Factor function (See Section 6.4) which involves no calibration reference solutions.
EEprom Fail	Internal nonvolatile memory failure	System failure, consult factory.
Chcksum Fail	Internal software storage error.	System failure, consult factory.
Display Fail	Internal display driver fail.	System failure, consult factory.
Range Cal Fail	Failure of factory temperature calibration.	Consult factory.

Spare Parts

<u>Part No.</u>	<u>Description</u>
03-0395	Q46C4 Front Lid Assembly
07-0330	Q46C4 Monitor, 100-240 VAC
07-0331	Q46C4 Monitor, 12-24 VDC
07-0332	Q46C4 Monitor, 100-240 VAC with Profibus
07-0333	Q46C4 Monitor, 12-24 VDC with Profibus
03-0407	Q46 P/S Assy, 100-240VAC
03-0408	Q46 P/S Assy, 100-240VAC with 3 rd 4-20mA output
03-0409	Q46 P/S Assy, 100-240VAC with 3 relay exp. board
03-0410	Q46 P/S Assy, 12-24 VDC
03-0411	Q46 P/S Assy, 12-24 VDC with 3 rd 4-20mA output
03-0412	Q46 P/S Assy, 12-24 VDC with 3 relay exp. Board
38-0072	Terminal block plug, 3 position (relays)
38-0073	Terminal block plug, 4 position (outputs)
38-0074	Terminal block plug, 3 position (ground)
38-0081	Terminal block plug, 3 position (power)
38-0084	Terminal block plug, 3 position (power) – VDC version*

***NOTE: prior to Dec 2018, VDC (power) Terminal block used the (38-0081)**

23-0029	Fuse, 630mA, 250V, TR-5 (for AC and DC Analyzers)
07-0100	Junction Box
00-1522	Sealed Flowcell Assembly
05-0110	Sealed Flowcell Vacuum Breaker
00-1526	Flow Type, Noryl body with connector
07-0055	Convertible, PEEK Body, 15'
07-0067	Convertible, PEEK Body, 30'
07-0090	Convertible, PEEK body with connector
07-0083	Insertion, 316 SS body
07-0098	Sanitary Style, 1 ½", 316 SS body
07-0068	Sanitary Style, 2", 316 SS body
03-0029	Sensor Cable with connector, 25'
31-0057	Sensor Interconnect cable
09-0046	Conductivity Standard – 84 microSiemens, 500 mL
09-0047	Conductivity Standard – 447 microSiemens, 500 mL
09-0048	Conductivity Standard – 1,500 microSiemens, 500 mL
09-0049	Conduvtivity Standard – 8,974 microSiemens, 500 mL
09-0050	Conductivity Standard – 80,000 microSiemens, 500 mL

Lock/Unlock Code: 1466