

Model Q46P pH Monitor

Home Office

Analytical Technology, Inc.
6 Iron Bridge Drive
Collegeville, PA 19426

Ph: 800-959-0299
610-917-0991

Fax: 610-917-0992

Email: sales@analyticaltechnology.com

European Office

ATI (UK) Limited
Unit 1 & 2 Gatehead Business Park
Delph New Road, Delph
Saddleworth OL3 5DE

Ph: +44 (0)1457-873-318

Fax: + 44 (0)1457-874-468

Email: sales@atiuk.com

PRODUCT WARRANTY

Analytical Technology, Inc. (Manufacturer) warrants to the Customer that if any part(s) of the Manufacturer's products proves to be defective in materials or workmanship within the earlier of 18 months of the date of shipment or 12 months of the date of start-up, such defective parts will be repaired or replaced free of charge. Inspection and repairs to products thought to be defective within the warranty period will be completed at the Manufacturer's facilities in Collegeville, PA. Products on which warranty repairs are required shall be shipped freight prepaid to the Manufacturer. The product(s) will be returned freight prepaid and allowed if it is determined by the manufacturer that the part(s) failed due to defective materials or workmanship.

This warranty does not cover consumable items, batteries, or wear items subject to periodic replacement including lamps and fuses.

Gas sensors, except oxygen sensors, are covered by this warranty, but are subject to inspection for evidence of extended exposure to excessive gas concentrations. Should inspection indicate that sensors have been expended rather than failed prematurely, the warranty shall not apply.

The Manufacturer assumes no liability for consequential damages of any kind, and the buyer by acceptance of this equipment will assume all liability for the consequences of its use or misuse by the Customer, his employees, or others. A defect within the meaning of this warranty is any part of any piece of a Manufacturer's product which shall, when such part is capable of being renewed, repaired, or replaced, operate to condemn such piece of equipment.

This warranty is in lieu of all other warranties (including without limiting the generality of the foregoing warranties of merchantability and fitness for a particular purpose), guarantees, obligations or liabilities expressed or implied by the Manufacturer or its representatives and by statute or rule of law.

This warranty is void if the Manufacturer's product(s) has been subject to misuse or abuse, or has not been operated or stored in accordance with instructions, or if the serial number has been removed.

Analytical Technology, Inc. makes no other warranty expressed or implied except as stated above.

Table of Contents

PART 1 - INTRODUCTION.....	4	PART 5 – CONFIGURATION.....	38
1.1 General.....	4	5.1 User Interface.....	38
1.2 Features	5	5.11 Keys	39
1.3 Q46P System Specifications.....	6	5.12 Display	39
1.4 Q46P Performance Specifications (Common to all variations).....	7	5.2 Software.....	41
1.5 General – Q25P pH Sensor	8	5.21 Software Navigation	41
1.6 Sensor Features	8	5.22 Measure Menu [MEASURE].....	44
1.7 Q25P Sensor Specifications	9	5.23 Calibration Menu [CAL].....	45
PART 2 – ANALYZER MOUNTING.....	11	5.24 Configuration Menu [CONFIG]	46
2.1 General.....	11	5.25 Control Menu [CONTROL]	52
2.2 Wall or Pipe Mount.....	12	5.26 Diagnostics Menu [DIAG].....	59
2.3 Panel Mounting.....	14	PART 6 – CALIBRATION	64
PART 3 – SENSOR/FLOWCELL MOUNTING ..	15	6.1 Overview and Methods.....	64
3.1 General.....	15	6.11 Sensor Slope.....	64
3.2 Flow Tee Mounting	16	6.12 Sensor Offset	65
3.3 Union Mounting.....	17	6.13 2-Point Calibration Explained	65
3.4 Submersion Mounting	18	6.14 1-Point Calibration Explained	65
3.5 Insertion Mounting	19	6.2 Performing a 2-Point Calibration.....	66
3.6 Conventional pH Sensors	21	6.3 Performing a 1-Point Calibration.....	67
3.61 Sealed Flowcell.....	22	6.4 Temperature Calibration.....	69
3.62 Flow Tee Adapter.....	23	PART 7 – PID CONTROLLER DETAILS	70
3.7 Lock-n-Load System	24	7.1 PID Description	70
PART 4 – ELECTRICAL INSTALLATION.....	25	7.2 PID Algorithm	70
4.1 General.....	25	7.3 Classical PID Tuning	72
4.2 Power Connection.....	26	7.4 Manual PID Override Control	73
4.3 Relay Connection.....	28	7.5 Common PID Pitfalls	73
4.4 Optional Output or Relay Connections	29	PART 8 – MAINTENANCE AND TROUBLESHOOTING	75
4.5 Sensor Wiring	30	8.1 System Checks	75
4.6 Direct Sensor Connection	33	8.2 Instrument Checks	75
4.7 Junction Box Connection	34	8.3 Display Messages	76
4.8 Combination Electrode Connection ..	35	8.4 Cleaning the Sensor.....	80
4.9 External Preamplifier.....	37	8.5 Replacing the Saltbridge and Reference Buffer Solution.....	81
		8.6 Troubleshooting	82
		SPARE PARTS.....	84

Table of Figures

<i>FIGURE 1 – Q46 ENCLOSURE DIMENSIONS</i>	<i>11</i>
<i>FIGURE 2 - WALL OR PIPE MOUNTING BRACKET</i>	<i>12</i>
<i>FIGURE 3 - WALL MOUNTING DIAGRAM</i>	<i>13</i>
<i>FIGURE 4 - PIPE MOUNTING DIAGRAM.....</i>	<i>13</i>
<i>FIGURE 5 - 115/230 VAC PANEL MOUNT & CUT-OUT</i>	<i>14</i>
<i>FIGURE 6 - Q25 SENSOR TYPES.....</i>	<i>15</i>
<i>FIGURE 7 - FLOW THROUGH TEE MOUNT</i>	<i>16</i>
<i>FIGURE 8 - 1.5" UNION MOUNT.....</i>	<i>17</i>
<i>FIGURE 9 - SENSOR SUBMERSION MOUNT</i>	<i>18</i>
<i>FIGURE 10 - S.S. SENSOR INSERTION MOUNT.....</i>	<i>19</i>
<i>FIGURE 11 - CPVC SENSOR INSERTION MOUNT.....</i>	<i>20</i>
<i>FIGURE 12 - (63-0013) COMBINATION PH SENSOR, FLOW TYPE.....</i>	<i>21</i>
<i>FIGURE 13 - (63-0009) COMBINATION PH SENSOR, SUB. TYPE.....</i>	<i>21</i>
<i>FIGURE 14 - SEALED FLOWCELL DETAILS.....</i>	<i>22</i>
<i>FIGURE 15 - TWIST-LOCK FLOW TEE</i>	<i>23</i>
<i>FIGURE 16 - LOCK-N-LOAD SENSOR EXPLODED VIEW.....</i>	<i>24</i>
<i>FIGURE 17 – Q46 CONNECTIONS</i>	<i>27</i>
<i>FIGURE 18 – Q46 RELAY CONNECTIONS.....</i>	<i>28</i>
<i>FIGURE 19 - OPTIONAL RELAY BOARD WIRING</i>	<i>29</i>
<i>FIGURE 20 - OPTIONAL ANALOG OUTPUT WIRING.....</i>	<i>29</i>
<i>FIGURE 21 - CABLE DESCRIPTION, MODEL Q25P</i>	<i>30</i>
<i>FIGURE 22 - DETACHABLE SINGLE SHIELDED CABLE, MODEL Q25P</i>	<i>31</i>
<i>FIGURE 23 - Q46P SENSOR CONNECTIONS</i>	<i>32</i>
<i>FIGURE 24 - SENSOR CABLE PREPARATION</i>	<i>33</i>
<i>FIGURE 25 - JUNCTION BOX INTERCONNECT WIRING</i>	<i>34</i>
<i>FIGURE 26 – OEM SENSOR CONNECTIONS, COMBINATION ELECTRODES</i>	<i>35</i>
<i>FIGURE 27 – ATI COMBINATION ELECTRODE CONNECTIONS.....</i>	<i>36</i>
<i>FIGURE 28 - EXTERNAL PREAMP FOR CONVENTIONAL SENSOR WIRING.....</i>	<i>37</i>
<i>FIGURE 29 - USER INTERFACE.....</i>	<i>38</i>
<i>FIGURE 30 - SOFTWARE MAP.....</i>	<i>43</i>
<i>FIGURE 31 - AUTOMATIC PH BUFFER TABLES.....</i>	<i>48</i>
<i>FIGURE 32 - AUTOMATIC PH BUFFER TABLES (CONT'D)</i>	<i>49</i>
<i>FIGURE 33 - CONTROL RELAY EXAMPLE, HYSTERESIS AND OPPOSITE PHASE.....</i>	<i>56</i>
<i>FIGURE 34 - ALARM RELAY EXAMPLE</i>	<i>57</i>
<i>FIGURE 35 - Q45H ISA (IDEAL) PID EQUATION</i>	<i>71</i>
<i>FIGURE 36 - REPLACING THE SALTBRIDGE AND REFERENCE BUFFER</i>	<i>81</i>

Part 1 - Introduction

1.1 General

The Model Q46P provides continuous measurement of pH in aqueous systems. It is suitable for potable water, wastewater, and a wide variety of process water applications. Q46P monitors may be used with Q25P “differential” pH sensors or a variety of conventional “combination” pH sensors.

Monitors are available in two electronic versions, a universal AC powered monitor for operation from 90-260 VAC and a 12-24 VDC unit. Both versions provide two 4-20 mA analog outputs and 3 SPDT relays. One analog output may be configured for PID control and one of the relays may be configured to provide a remote trouble indication.

The Q46P is available with a few options to expand the capabilities of the monitor. Users may select either a third analog 4-20 mA output or an expansion card that provides three additional low voltage SPST relays. The expansion relays are not isolated from each other.

This monitor also provides digital communication capability. Users may order Q46 systems with either Profibus DP, Modbus RTU, or Ethernet communications boards factory installed.

1.2 Features

- Standard Q46P Analyzers have fully isolated inputs and outputs. Analog outputs are additionally completely isolated from each other.
- Available in either 90-260 VAC or 12-24 VDC power supply systems. All features remain the same in both variations.
- Output Hold, Output Simulate, Output Alarm, and Output Delay Functions. All forced changes in output condition include bumpless transfer for gradual return to on-line signal levels to avoid system control shocks on both analog outputs.
- Three 6 amp SPDT relay outputs and two analog 4-20 mA outputs are standard. Software settings for relay control include setpoint, deadband, phase, delay, and failsafe. An optional 3-relay card, for 0-30 V signals, is available to bring the total to 6 relays.
- Selectable PID controller on main analog output. PID controller can operate with instrument configured as loop-power analyzer or as one of the two outputs on the AC powered instrument. PID includes manual operation feature, and diagnostic “stuck-controller” timer feature for alarm output of control problems.
- Digital communication option for Profibus-DP, Modbus-RTU. More versions pending. See Q46 Digital Communications Manual for Specifications.
- Two analog outputs may be configured to track pH and temperature. Both analog outputs can be individually programmed to fail to specific values. An optional third output is available, providing separate outputs for pH or Temperature.
- Low voltage relay expansion board provides for analyzer control of the optional “air blast” sensor cleaning system available for submersion applications.
- Sensor diagnostics monitor glass breakage, sensor leaks, and RTD condition. Diagnostic messages provide a clear description of problems.
- Two-point and sample calibration methods include auto-buffer recognition from 13 built-in buffer tables, with stability checks during calibration.
- Selectable Pt1000 or Pt100 temperature inputs.
- Security lock feature to prevent unauthorized tampering.

1.3 Q46P System Specifications

Displayed Parameters	Main input, 0.00 to 14.00 pH Sensor temperature, -10.0 to 110.0 °C (14 to 230°F) Loop current, 4.00 to 20.00 mA Sensor slope/offset Model number and software version
Enclosure	NEMA 4X, polycarbonate, stainless steel hardware, weatherproof and corrosion resistant.
Mounting Options	Wall or pipe mount bracket standard. Bracket suitable for either 1.5" or 2" I.D. U-Bolts for pipe mounting. Panel mounting bracket optional.
Weight	2 lb. (0.9 kg)
Display	0.75" (19.1 mm) high 4-digit main display with sign 12-digit secondary display, 0.3" (7.6 mm) 5x7 dot matrix. Integral LED back-light for visibility in the dark.
Keypad	4-key membrane type, polycarbonate
Ambient Temperature	Service, -20 to 60 °C (-4 to 140 °F) Storage, -30 to 70 °C (-22 to 158 °F)
Ambient Humidity	0 to 95%, indoor/outdoor use, non-condensing.
Altitude	Up to 2000 m (6562 Ft.)
Electrical Certification	Ordinary Location, cCSAus (CSA and UL standards - both approved by CSA), pollution degree 2, installation category 2
EMI/RFI Influence	Designed to EN 61326-1
Output Isolation	600 V galvanic isolation
Filter (Damping)	Adjustable 0-9.9 minutes damping to 90% step input change.
Temperature Input	Selectable Pt1000 or Pt100 RTD with automatic compensation
Power	90 - 260 VAC, 50-60 Hz, 10 VA max 12-24 VDC, 500 mA max.

Enclosure	NEMA 4X, polycarbonate, stainless steel hardware, weatherproof and corrosion resistant.
Mounting Options	Wall or pipe mount bracket standard. Bracket suitable for either 1.5" or 2" I.D. U-Bolts for pipe mounting. Panel mount adapter optional.
Conduit Openings	Five ½" NPT openings, Adapter can be removed to provide a 1" NPT opening in the bottom of the enclosure. Gland seals provided but not installed.
Relays, Electromechanical:	Three SPDT, 6 amp @ 250 VAC, 5 amp @ 24 VDC contacts. Software selection for setpoint, phase, delay, deadband, hi-lo alarm, and failsafe. A-B indicators on main LCD, and C indicator on lower display.
Expansion Relays:	Optional relay board with 3 SPST low power relays. Relays rated 2A @ 30 VDC. Relays are not isolated.
Analog Outputs	Two 4-20 mA outputs. Output one programmable for pH or PID. Output 2 programmable for pH or Temperature. Max load 500 Ohms for each output. Outputs ground isolated and isolated from each other. An additional 3 rd analog option is available.

1.4 Q46P Performance Specifications (Common to all variations)

Accuracy	0.1% of span or better (± 0.01 pH)
Repeatability	0.1% of span or better (± 0.01 pH)
Sensitivity	0.05% of span (± 0.01 pH)
Stability	0.05% of span per 24 hours, non-cumulative
Supply Voltage Effects	$\pm 0.05\%$ span
Instrument Response Time	6 seconds to 90% of step input at lowest setting
Temperature Drift	Span or zero, 0.02% of span/ $^{\circ}$ C
Max. Sensor-Instrument Distance	3,000 ft. (914 meters) w/ preamp, 30 ft. (9.1 meters) w/o preamp
Sensor Types	Model Q25P pH w/ preamp - 5 wire input, or combination style pH electrode w/ TC

1.5 General – Q25P pH Sensor

Model Q25P “differential” pH sensors are the most commonly used sensors with the Q46P monitor. The differential design utilizes a second glass measuring electrode contained in an internal buffer as the reference element. This eliminates the need for a silver/silver chloride reference used in conventional pH sensor designs. It is designed to perform in the harshest of environments, including applications that poison conventional pH sensors. All seals are dual o-ring using multiple sealing materials.

Q25P sensors are available with a choice of two glass types. For the most demanding industrial applications, P1 glass should be used. This glass is thicker and will last longer in higher temperature and pressure applications. On the other hand, P1 glass has a very high impedance and is not suggested for use in very cold applications. P2 glass is a good general purpose glass that is better for drinking water, wastewater, and low temperature industrial applications. This glass is somewhat thinner with lower impedance and can handle cold water more easily. Note that the salt bridge is different for these two sensors.

1.6 Sensor Features

- A high volume, dual junction saltbridge to maximize the in-service lifetime of the sensor. The annular junction provides a large surface area to minimize the chance of fouling. Large electrolyte volume and dual reference junctions minimize contamination. The saltbridge is replaceable.
- An integral preamplifier encapsulated provides a low impedance signal output which ensures stable readings in noisy environments. Sensor to transmitter separation can be up to 3,000 feet (914 meters).
- Pt1000 RTD. The temperature element used in ATI sensors is highly accurate and provides a highly linear output.
- Available in various configurations including submersible, flow type with quick disconnect, sanitary, and insertion.

1.7 Q25P Sensor Specifications

Measuring Range	0 to 14.00 pH
Sensitivity	0.01 pH
Stability	0.02 pH per 24 hours, non-cumulative
Wetted Materials	PEEK, ceramic, titanium, glass, Viton, EDPM (optional: 316 stainless steel body)
Temperature Compensation	Pt1000 RTD
Sensor Cable	6 Conductor (5 are used) plus 2 shields, 15 feet (4.6 meters) standard length
Temperature Range	-5 to +95 °C (23 to 203 °F)
Pressure Range	0 to 100 psig
Maximum Flow Rate	10 feet (3 meters) per second
Sensor to Analyzer Distance	3,000 feet (914 meters) maximum
Sensor Body Options	1" NPT convertible, 1¼" insertion, 1½" or 2" sanitary-style
Weight	1 lb. (0.45 kg)

Notes: 1. The type of hardware used to mount the sensor may limit the maximum temperature and pressure ratings. Please consult the hardware manufacturer's specifications to obtain the relevant temperature and pressure rating information.

2. The maximum flow rate specification is lower for process solutions with low ionic conductivity or high suspended solids concentration. High flow rates in low ionic conductivity processes may cause a measurement error due to static electrical discharge. High flow rates in processes with high suspended solids concentration may decrease the functional life of the sensor by eroding the pH-sensitive glass electrode.

1.8 Important Sensor Notes

- The glass electrode must be wetted at all times to ensure proper functionality. Q25P sensors are shipped with a fluid-filled cap over the electrode to enable immediate use (remove cap before installing, save for storage and shipping purposes). Electrodes that have dried out for any reason should be hydrated for 24 hours to restore full functionality.
- Hydrofluoric acid (HF) will dissolve conventional glass electrodes. For applications involving hydrofluoric acid, a pH sensor with antimony electrode is recommended.



NOTE: The standard Q25P process electrode is made of glass and can break if not handled properly. Should the electrode ever break, **USE CAUTION** when handling the sensor to avoid serious cuts.



Equipment bearing this marking may not be discarded by traditional methods in the European community after August 12 2005 per EU Directive 2002/96/EC. End users must return old equipment to the manufacturer for proper disposal.



Part 2 – Analyzer Mounting

2.1 General

All Q46 Series instruments provide for mounting flexibility. A bracket is included that allows mounting to walls or pipes. In all cases, choose a location that is readily accessible for calibrations. Also consider that it may be necessary to utilize a location where solutions can be used during the calibration process. To take full advantage of the high contrast display, mount the instrument in a location where the display can be viewed from various angles and long distances.

Locate the instrument in close proximity to the point of sensor installation - this will allow easy access during calibration. The standard cable length of the pH sensor is 15 feet. For sensor cables longer than 30 feet, use the optional junction box (07-0100) and sensor interconnect cable (31-0057).

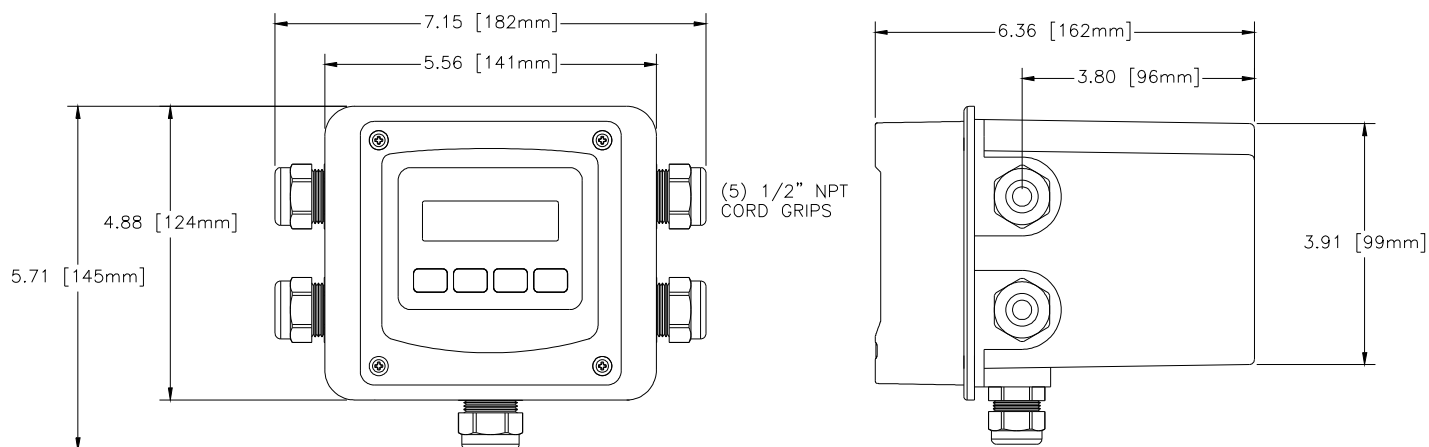

Figure 1 – Q46 Enclosure Dimensions

2.2 Wall or Pipe Mount

A PVC mounting bracket with attachment screws is supplied with each transmitter. The multi-purpose bracket is attached to the rear of the enclosure using the four flat head screws. The instrument is then attached to the wall using the four outer mounting holes in the bracket. These holes are slotted to accommodate two sizes of u-bolt that may be used to pipe mount the unit. Slots will accommodate u-bolts designed for 1½ “or 2” pipe. The actual center to center dimensions for the u-bolts are shown in the drawing. Note that these slots are for u-bolts with ¼-20 threads. The 1½” pipe u-bolt (2” I.D. clearance) is available from ATI in type 304 stainless steel under part number (47-0005).

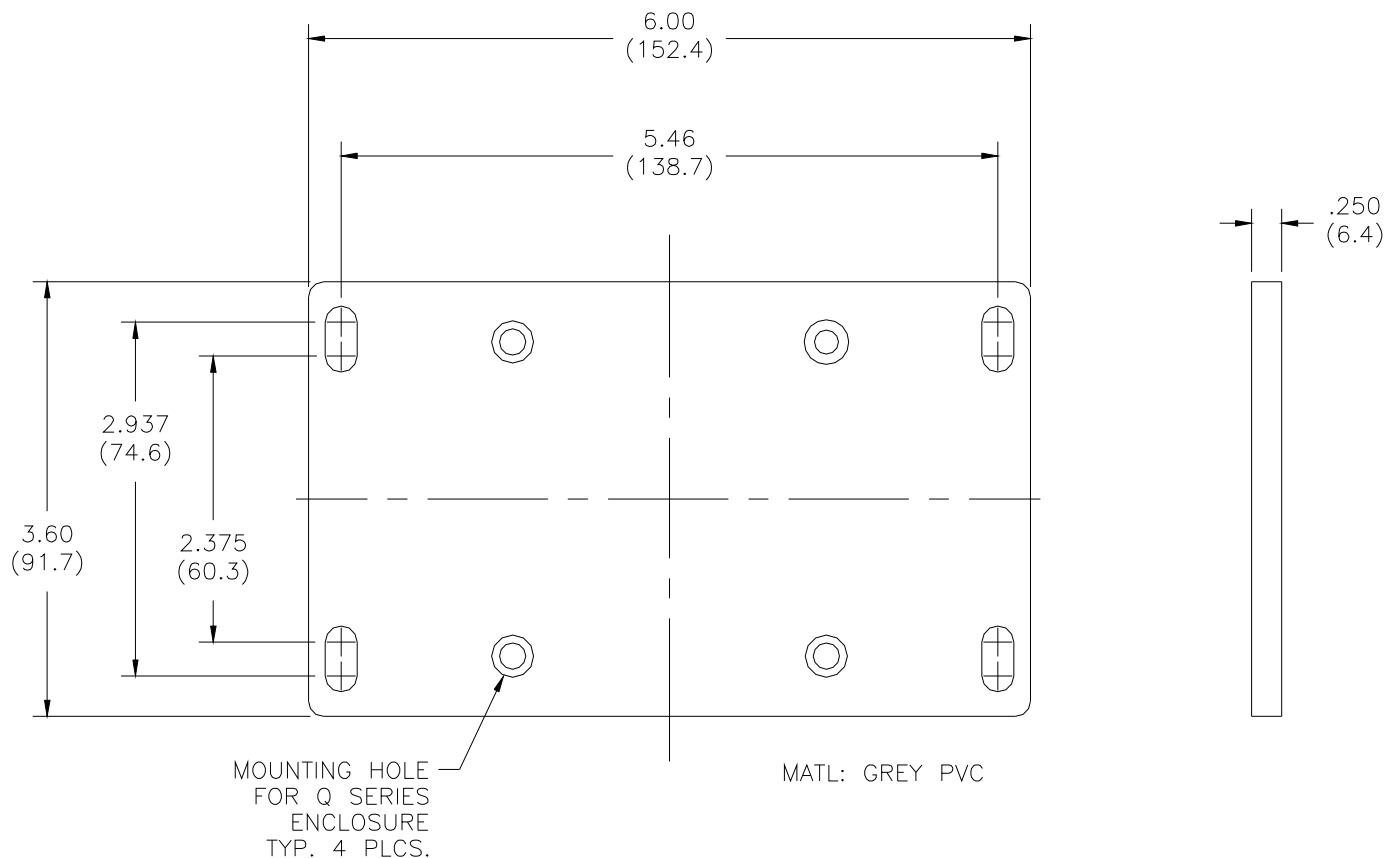
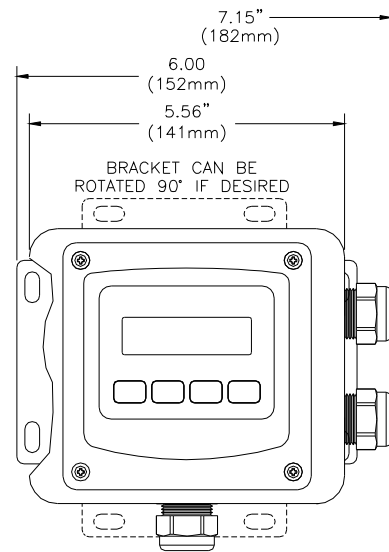
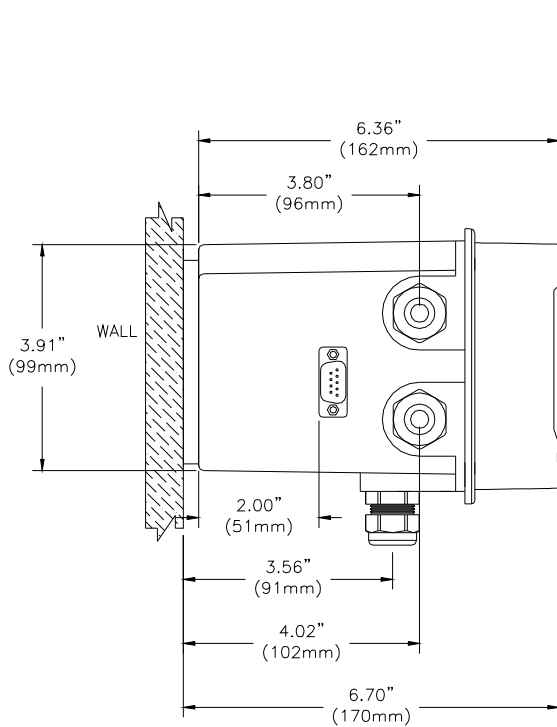

Figure 2 - Wall or Pipe Mounting Bracket



Note: Analyzer shown with optional Profibus Connector mounted to side of enclosure.

Figure 3 - Wall Mounting Diagram

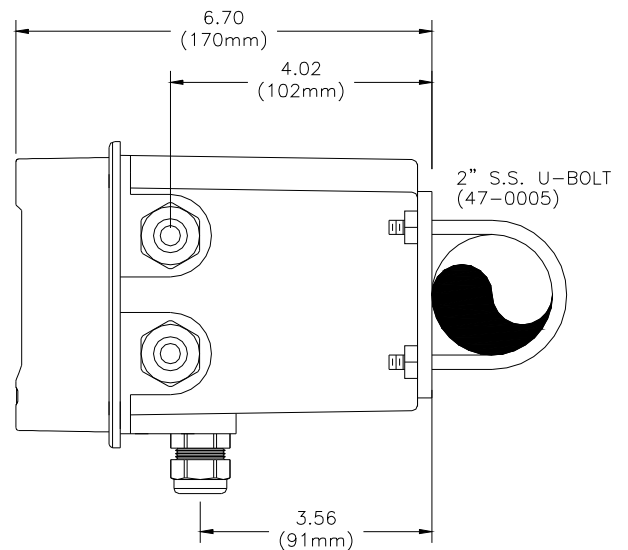
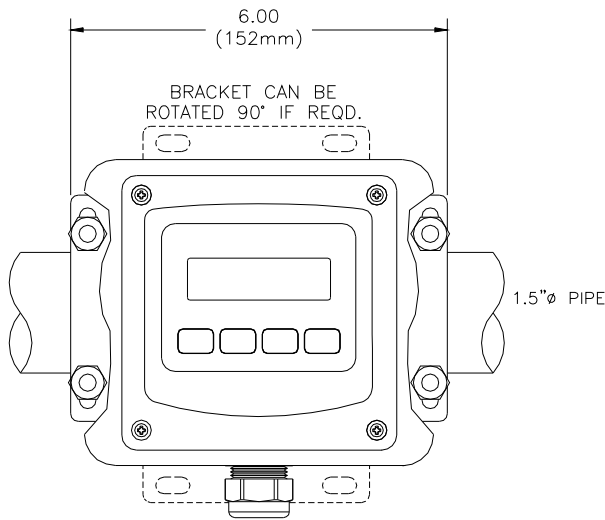

Figure 4 - Pipe Mounting Diagram

2.3 Panel Mounting

Panel mounting uses the panel mounting flange molded into the rear section of the enclosure. Figure 5 provides dimensions for the panel cutout required for mounting.

The panel mounting bracket kit must be ordered separately (part number 05-0094). This kit contains a metal retainer bracket that attaches to the rear of the enclosure, 4 screws for attachment of this bracket, and a sealing gasket to insure that the panel mounted monitor provides a water tight seal when mounted to a panel.

The sealing gasket must first be attached to the enclosure. The gasket contains an adhesive on one side so that it remains in place on the enclosure. Remove the protective paper from the adhesive side of the gasket and slide the gasket over the back of the enclosure so that the adhesive side lines up with the back of the enclosure flange. Once in place, you can proceed to mount the monitor in the panel.

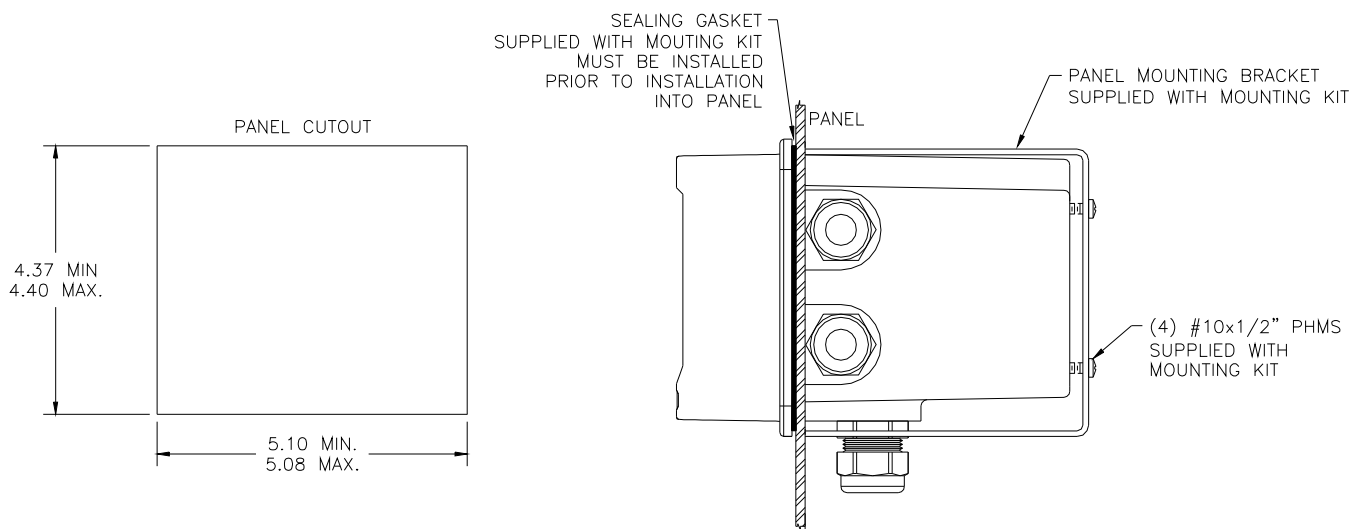

Figure 5 - 115/230 VAC Panel Mount & Cut-out

Part 3 – Sensor/Flowcell Mounting

3.1 General

The Q25P pH Sensor mounting options include flow-through, submersion, insertion (special hardware required), or sanitary mount depending on the type of sensor purchased.

Q25P Differential pH Sensors are available in 4 different versions as shown in Figure 6. The convertible style is the most common and can be used for either flow-through or submersion applications. A convertible sensor with a quick-disconnect receptacle is available. This version may not be submerged and should not be used in unprotected outdoor locations. For special applications, the Q25P is also available in a stainless steel bodied version for insertion type installations, or can be supplied in either 1.5" or 2" sanitary versions.

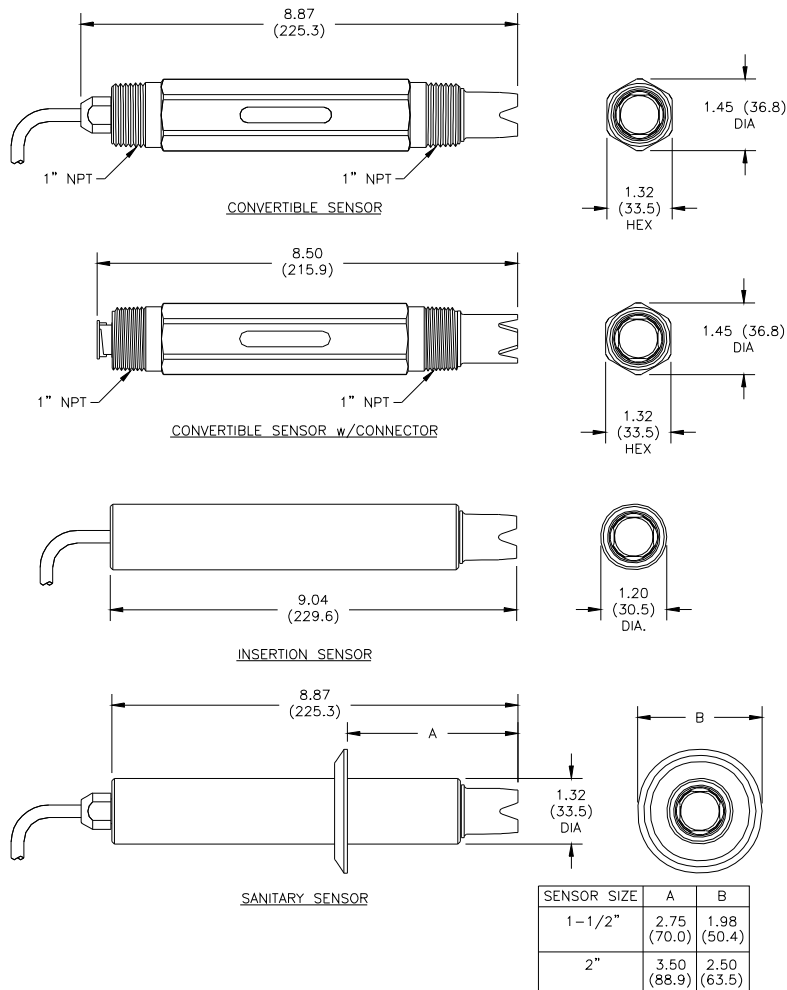

Figure 6 - Q25 Sensor Types

3.2 Flow Tee Mounting

Convertible sensors may be used in a 1" flow tee as shown in Figure 7. The flow tee is a modified pipe fitting that accommodates the pipe thread on the front of the sensor. Sample must flow directly against the face of the sensor as shown. The sensor may be mounted horizontally provided that the outlet flow is pointed up to avoid "air locking" in the tee. Note that standard 1" tee fittings will not work without modification due to clearance problems in most molded tees.

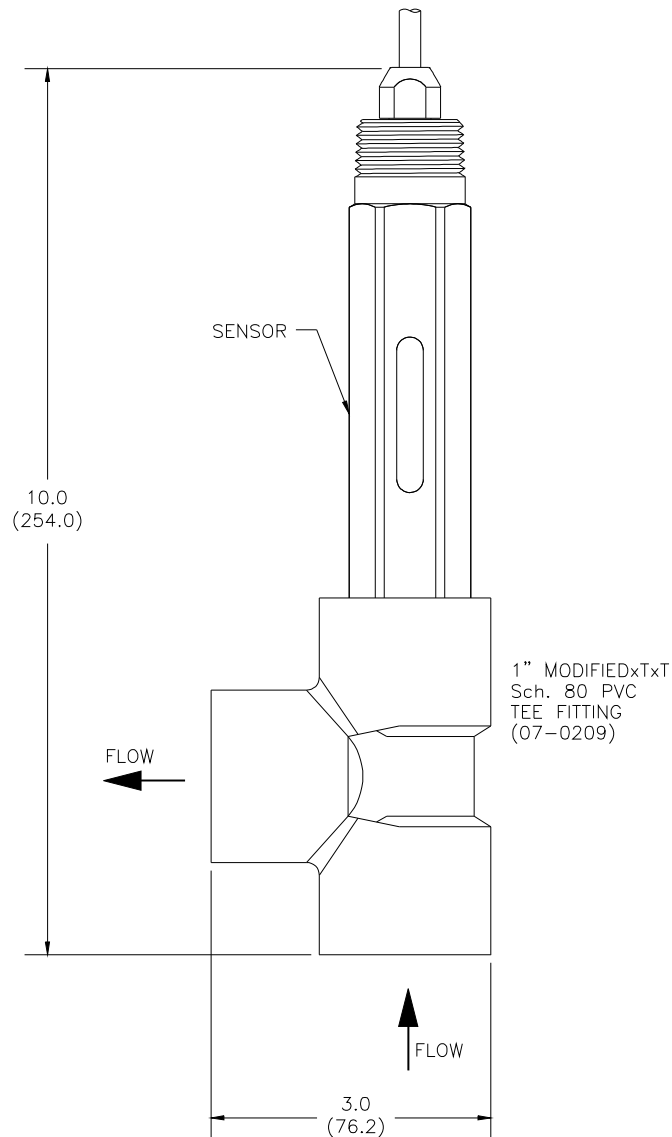

Figure 7 - Flow Through Tee Mount

3.3 Union Mounting

For mounting the sensor in larger pipe and allowing for easy sensor removal, a 1 1/2" or 2" union mount adapter system is available. This arrangement allows connection of the sensor to pipe sizes up to 2 inches (using adapters if necessary) while allowing easy removal without twisting sensor wires. Contact ATI for part numbers and prices for union mount assemblies and associated pipe tees. The 1 1/2" assembly is shown below. The 2" tee assembly is similar.

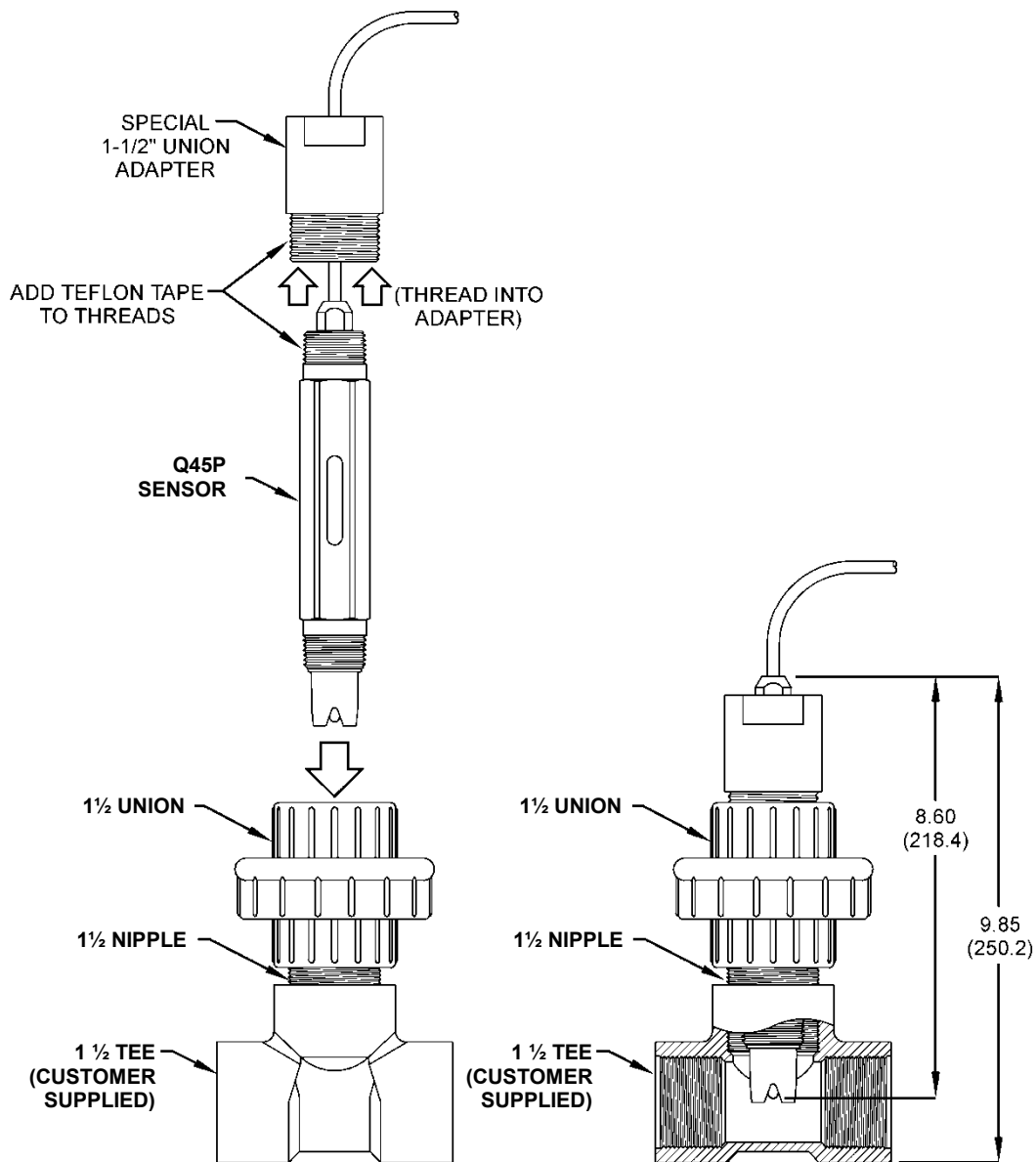

Figure 8 - 1.5" Union Mount

3.4 Submersion Mounting

When using this sensor for submersion applications, mount the sensor to the end of a 1" mounting pipe using a 1" coupling. ATI's (00-0628) mounting assembly shown in Figure 9 is available for submersible applications. This assembly is designed to mount to standard handrails and facilitates insertion and removal of the sensor.

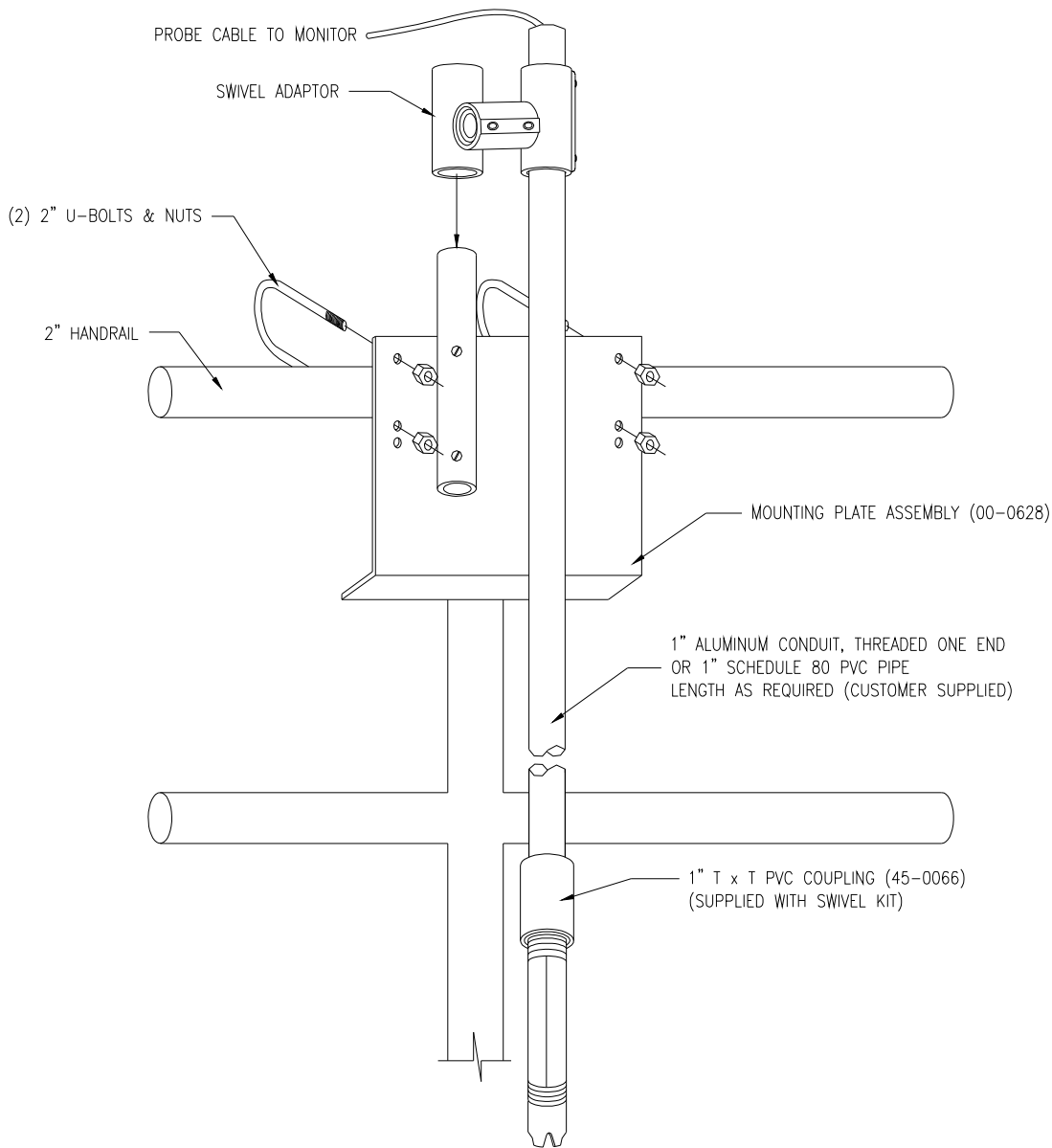

Figure 9 - Sensor Submersion Mount

3.5 Insertion Mounting

Special insertion mounting hardware is available for applications requiring the removal of the sensor from a process line or tank without shutting off the sample flow in the line. Figure 10 & Figure 11 show typical insertion assemblies.

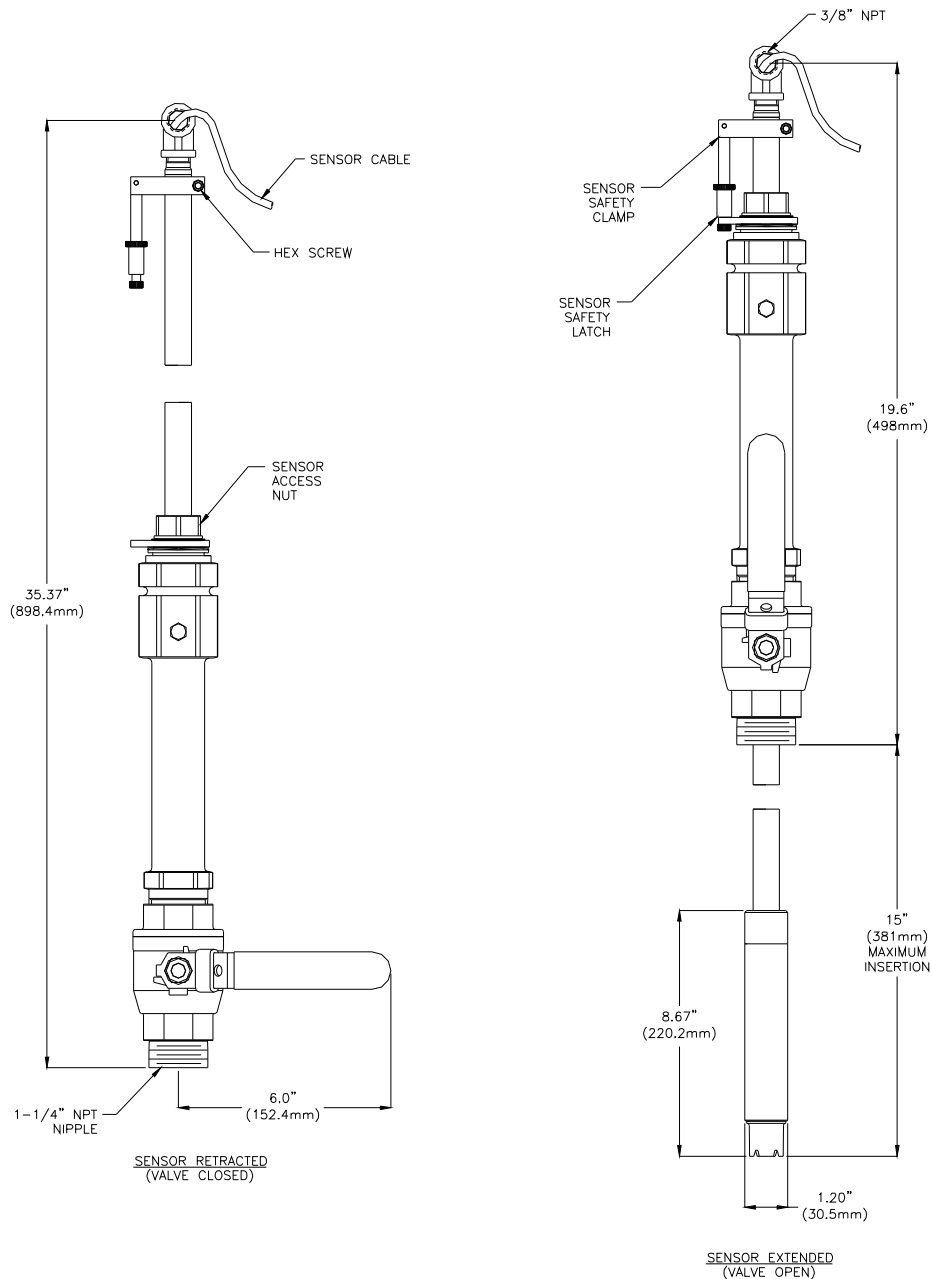

Figure 10 - S.S. Sensor Insertion Mount

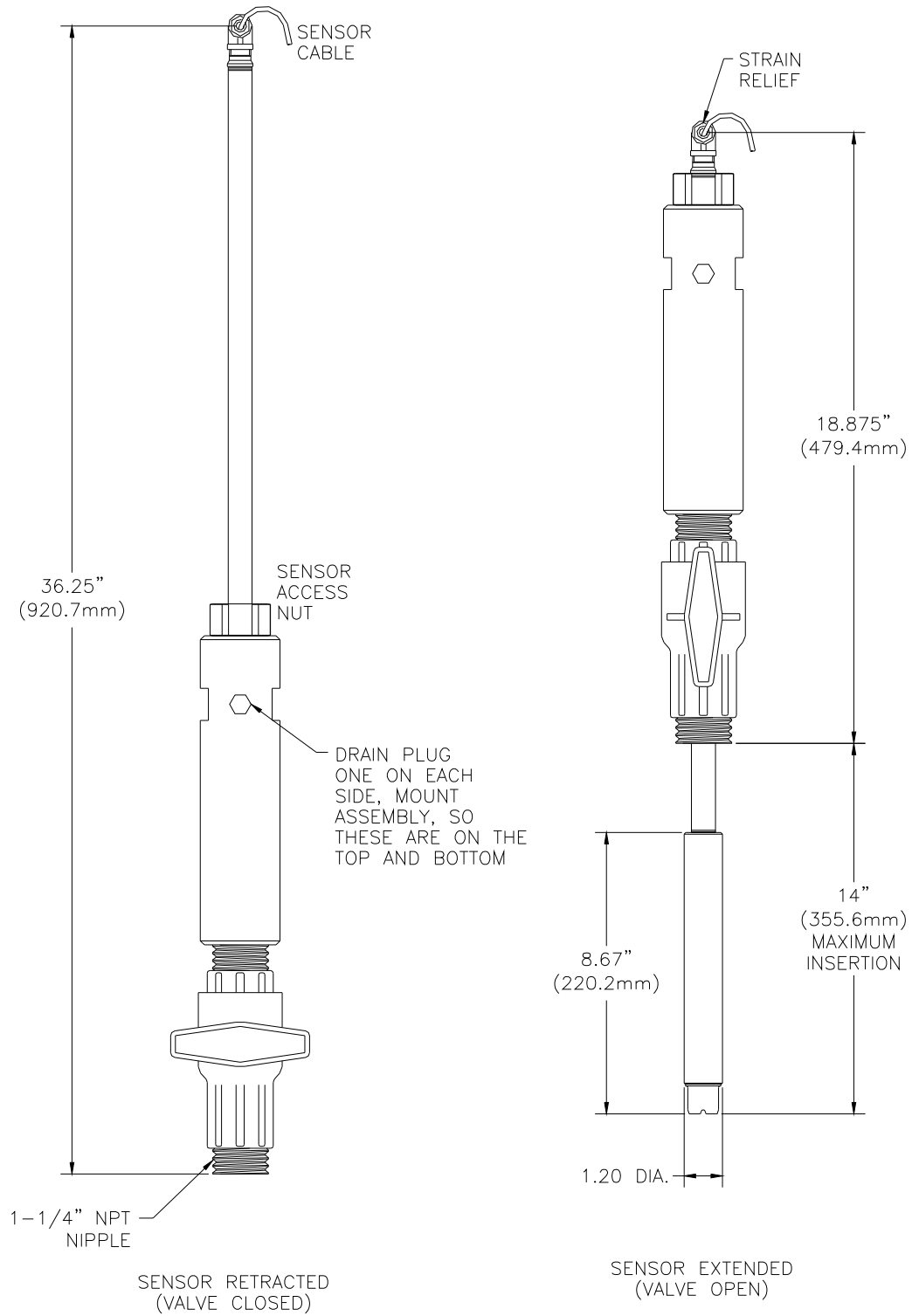

Figure 11 - CPVC Sensor Insertion Mount

3.6 Conventional pH Sensors

As indicated previously, Model Q46P transmitters may be used with standard combination pH sensors available from a variety of manufacturers. For simple clean water applications, these lower cost sensors may be all that's needed for reliable monitoring. ATI offers a few of these types of sensors as standard items and can assist with the selection of special sensors should the need arise.

Figure 12 below show the dimensions of two pH sensors frequently used with the Q46P. The 63-0013 sensor is suitable for use with either a pipe tee adapter or a special clear acrylic sealed flowcell.

The 63-0009 pH sensor with flat glass tip is suitable for submersion use, or for screwing directly into a pipe tee. If using in a tee, be careful to allow for enough slack cable so that the cable does not twist excessively.

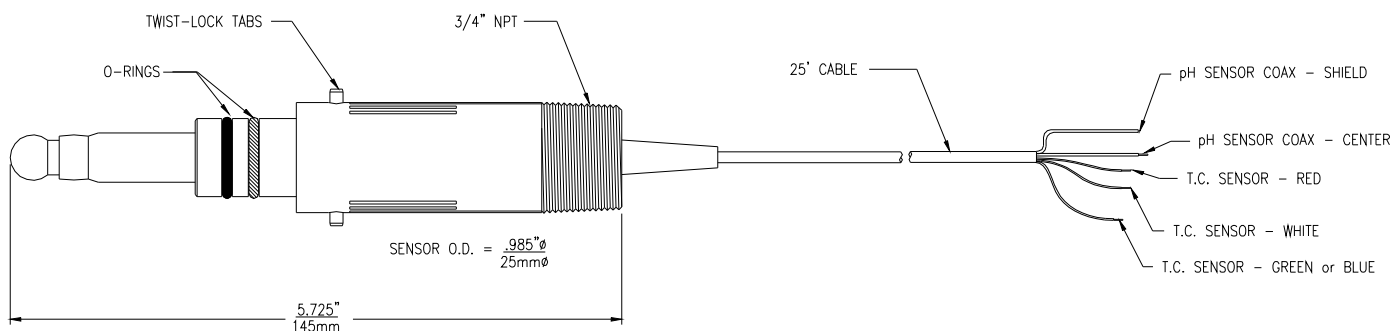

Figure 12 - (63-0013) Combination pH Sensor, Flow Type

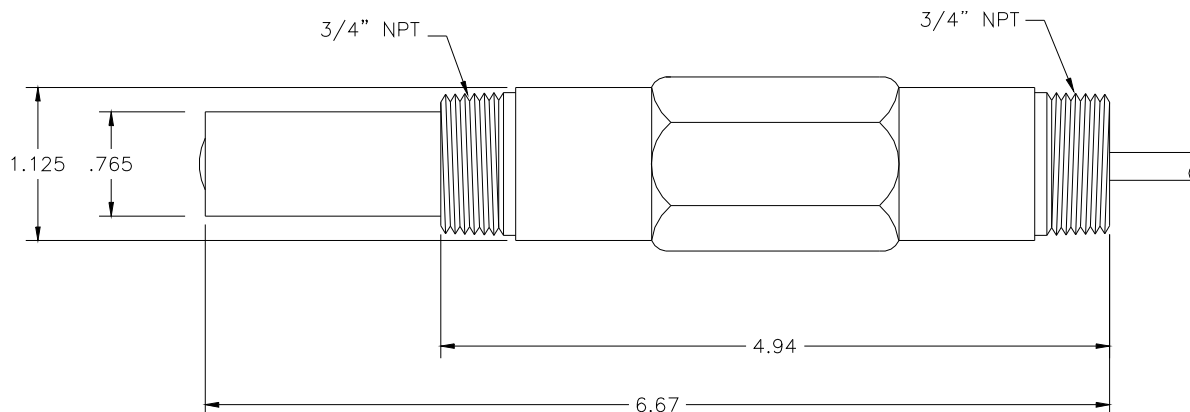

Figure 13 - (63-0009) Combination pH Sensor, Sub. Type

3.61 Sealed Flowcell

For applications where a flowcell is desired, a sealed flowcell (00-1527) shown in Figure 14 is available. This flowcell is used only with sensor (63-0005) or (63-0013) and may be used for sample pressures up to 75 PSIG. The sample flow should be controlled to 300-800 cc/min. When using this flowcell for pH measurement, put the flow control valve **AFTER** the flowcell. This will maintain sample pressure through the flowcell and avoid “degassing” of the sample. Degassing can lead to bubbles on the end of the sensor which will cause erratic readings. **If degassing cannot be avoided, mount the flowcell horizontally with the inlet on the side and the outlet on the top so that air bubbles naturally flow away from the sensor tip.**

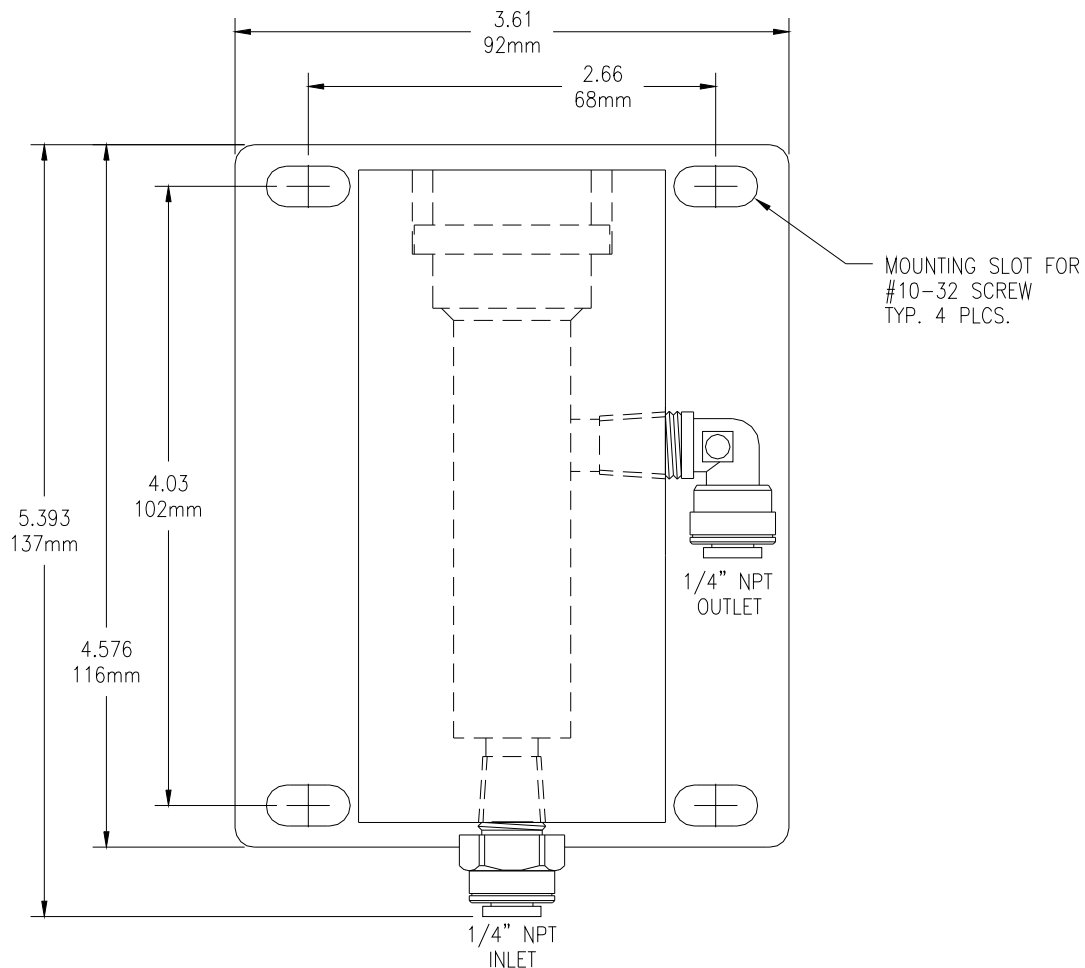

Figure 14 - Sealed Flowcell Details

3.62 Flow Tee Adapter

When using the 63-0013 sensor in a flow application, a 1" or 3/4" pipe tee adapter is required. Figure 15 shows a detail of that arrangement.

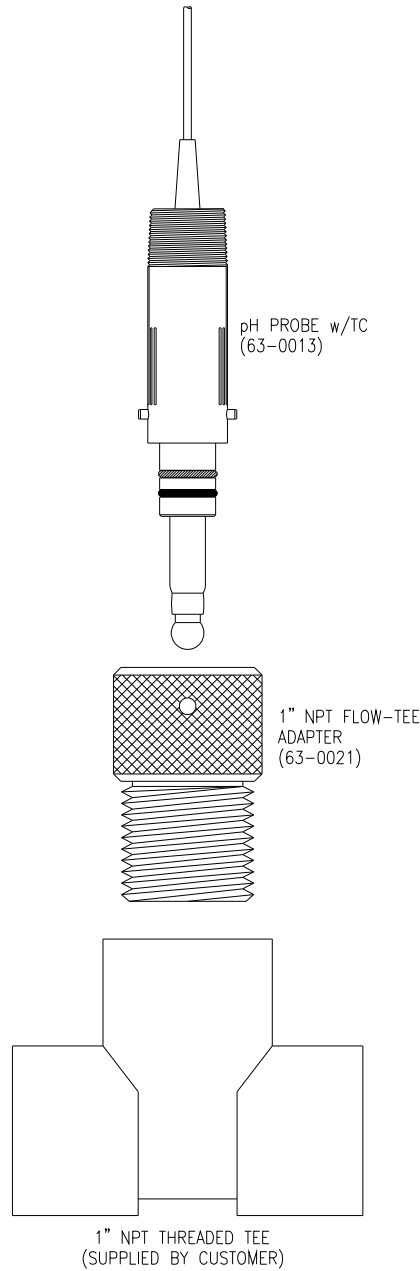

Figure 15 - Twist-Lock Flow Tee

3.7 Lock-n-Load System

A special sensor/flowcell system is available that allows insertion and removal of a pH sensor under flow conditions. Called a Lock-n-Load system, this assembly uses a 2" flow tee and special sensor holder that retracts the sensor from a flowing sample for maintenance and cleaning. It is simpler than an insertion assembly and is very useful in lower pressure and clean water applications.

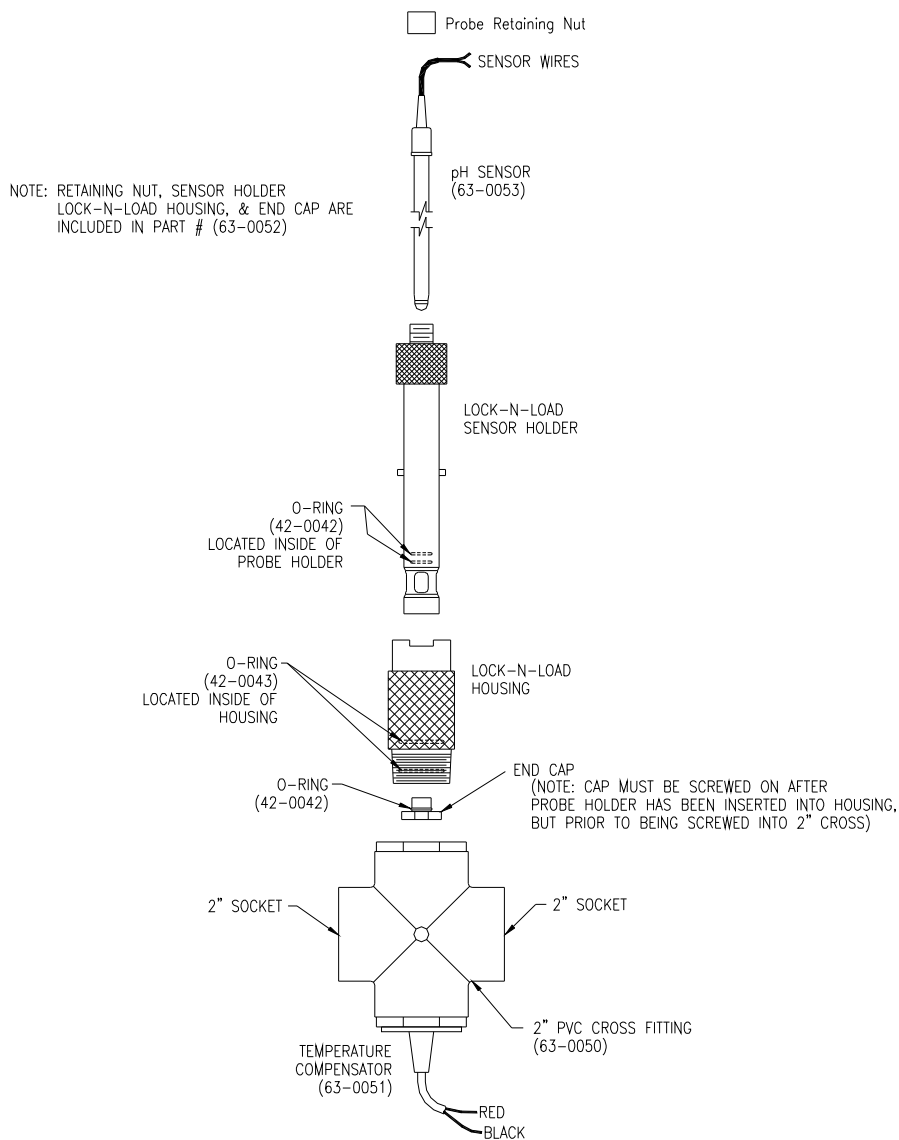

Figure 16 - Lock-n-Load Sensor Exploded View

Part 4 – Electrical Installation

4.1 General

The Q46 is powered in one of two ways, depending on the version purchased. The 12-24 VDC powered analyzer requires a customer supplied DC power supply. The 90-260 VAC version requires line power. Please verify the type of unit before connecting any power.



WARNING: Do not connect AC line power to the DC version. Severe damage will result.

Important Notes:

1. Use wiring practices that conform to all national, state and local electrical codes. For proper safety as well as stable measuring performance, it is important that the earth ground connection be made to a solid ground point from TB7. The AC power supply contains a single 630mA slo-blo fuse (Wickmann/Littlefuse #372-0630). The fuse **F1** is located adjacent to **TB7** and is easily replaceable.
2. Do NOT run sensor cables or instrument 4-20 mA output wiring in the same conduit that contains AC power wiring. AC power wiring should be run in a dedicated conduit to prevent electrical noise from coupling with the instrumentation signals.
3. This analyzer must be installed by specifically trained personnel in accordance with relevant local codes and instructions contained in this operating manual. Observe the analyzer's technical specifications and input ratings. Proper electrical disconnection means must be provided prior to the electrical power connected to this instrument, such as a circuit breaker - rated 250 VAC, 2 A minimum. If one line of the line power mains is not neutral, use a double-pole mains switch to disconnect the analyzer.
4. Repeated problems with lightning strikes damaging sensitive instrumentation are often attributed to poorly bonded earth grounds in the instrument power source. The protection schemes incorporated into this analyzer cannot operate to maximum efficiency unless the ground connection is at its' absolute lowest impedance.

There is no standard ground resistance universally recognized. Many agencies recommend a ground resistance value of 5 ohms or less. The NEC recommends an impedance to ground of less than 25 ohms, and less than 5 ohms where sensitive equipment is installed. Power sources feeding sensitive instruments like the Q46H/79PR should have the lowest possible impedance to ground.

4.2 Power Connection

Verify the AC power supply requirement before installing. Also verify that power is fully disconnected before attempting to wire.

Q46 systems are supplied with 5 cable gland fittings for sealing cable entries.

Connect HOT, NEUTRAL, and GROUND to the matching designations on terminal strip **TB7**.

WARNING

Disconnect line power voltage BEFORE connecting line power wires to Terminal TB7 of the power supply. The power supply accepts only standard three-wire single phase power. AC power supplies are configured for 90-260 VAC operation at the factory at time of order, and the power supply is labeled as such. Do NOT connect voltages other than the labeled requirement to the input.

The two analog outputs for the standard system are present at terminal TB1. The loop-load limitation in this configuration is 500 Ohms maximum for each output. Also note that these two outputs are completely isolated from each other to insure that ground loops do not result from the connection of both outputs to the same device such as a PLC or DCS.

A ribbon cable connects the power supply assembly with the microprocessor assembly located in the front section of the enclosure. This cable may be unplugged from the front section of the monitor if service is needed, but should normally be left in place during installation.

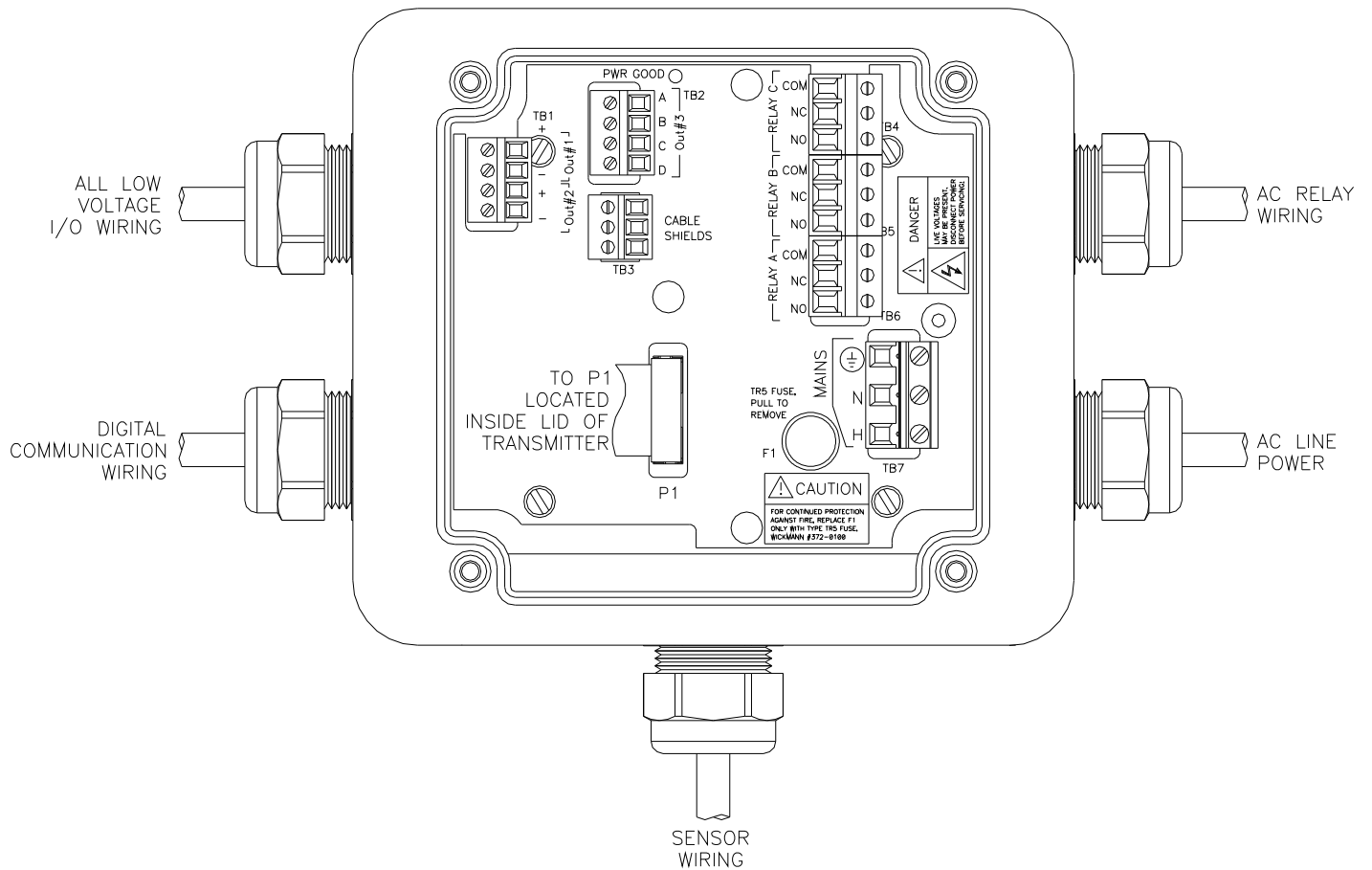

Figure 17 – Q46 Connections

The power strip, **TB7**, allows up to 12 AWG wire. A wire gauge of 16 AWG is recommended to allow for an easy pass-through into the 1/2" NPT ports when wiring.

4.3 Relay Connection

Three SPDT relays are provided on the power supply board. None of the relay contacts are powered. The user must supply the proper power to the contacts. For applications that require the same switched operating voltage as the Q46 (115 or 230 V), power may be jumpered from the power input terminals at **TB7**. Relay wiring is connected at **TB4, TB5, and TB6** as shown below. Note that the relay contact markings are shown in the NORMAL mode. Programming a relay for “Failsafe” operation reverses the NO and NC positions in this diagram (Figure 18).

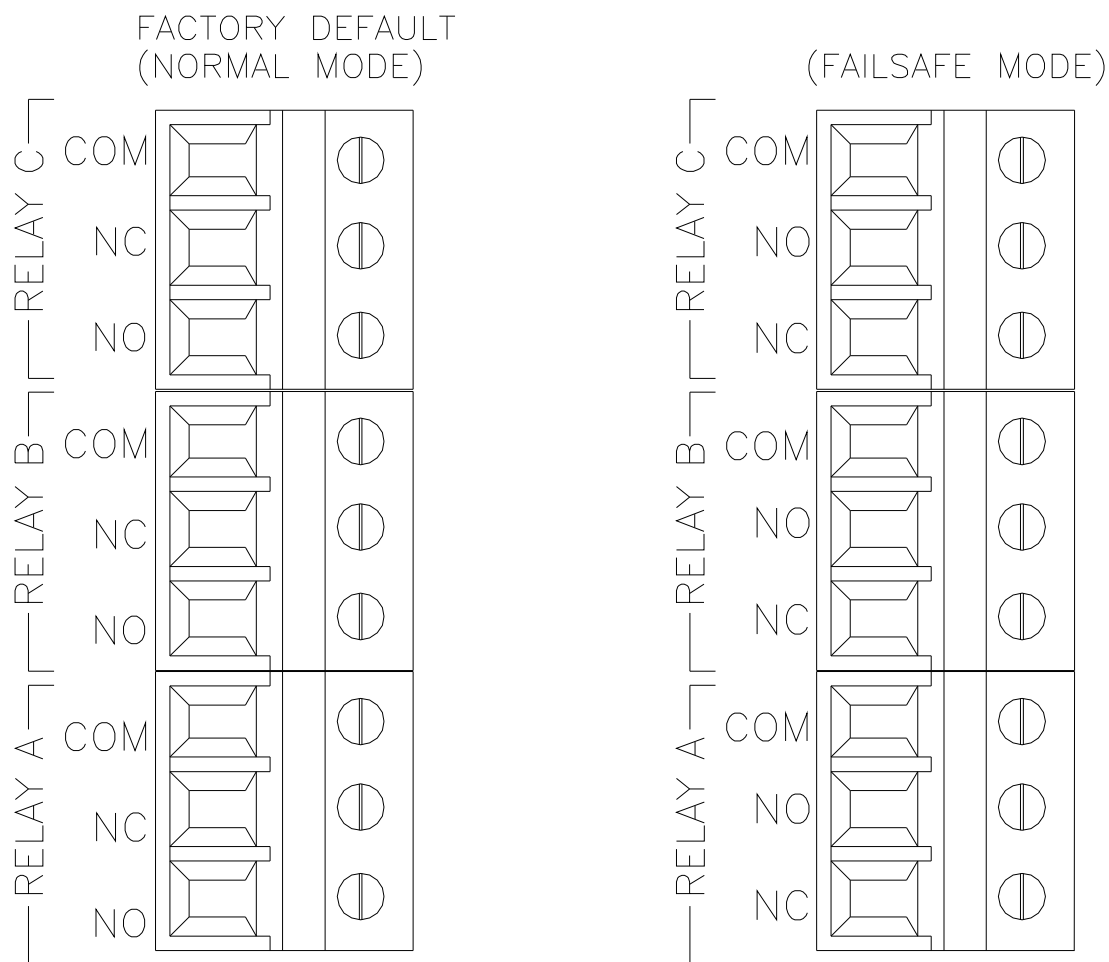

Figure 18 – Q46 Relay Connections

4.4 Optional Output or Relay Connections

TB2, is used to connect to the optional 3-relay card (Figure 19) **OR** the optional third analog output Out#3, (Figure 20). The Q46 can be configured for only one of these optional features, and the hardware for either option must be factory installed.

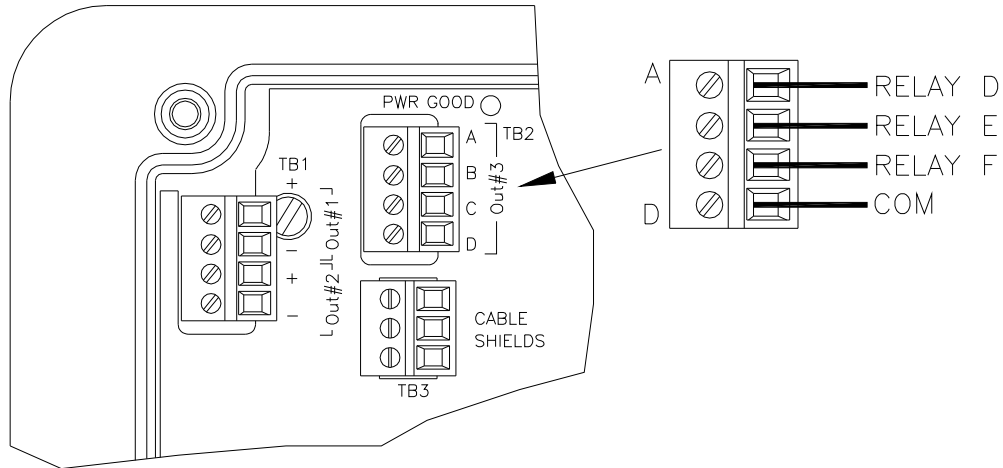

Figure 19 - Optional Relay Board Wiring

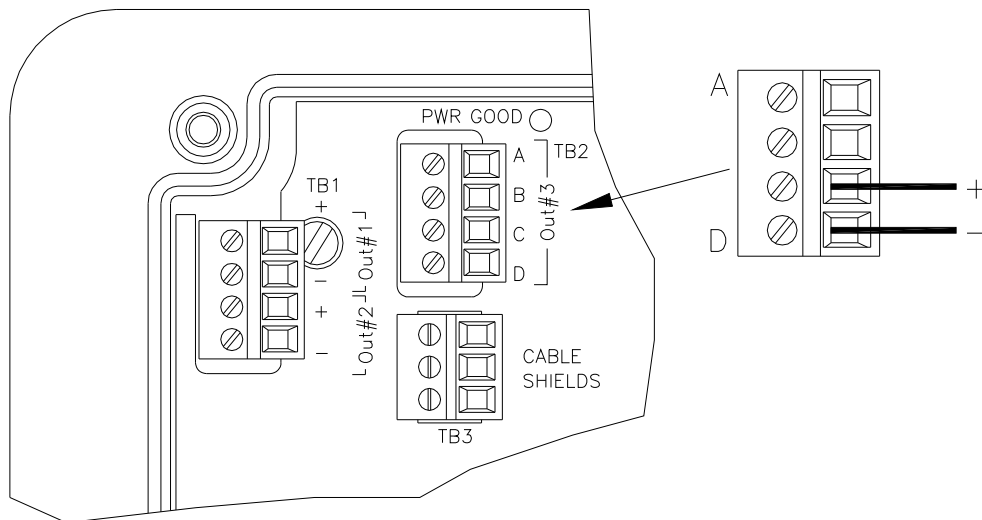

Figure 20 - Optional Analog Output Wiring

4.5 Sensor Wiring

The sensor cable can be quickly connected to the Q46 terminal strip by matching the wire colors on the cable to the color designations on the label in the monitor. A junction box is also available to provide a break point for long sensor cable runs. Route signal cable away from AC power lines, adjustable frequency drives, motors, or other noisy electrical signal lines. Do not run sensor or signal cables in conduit that contains AC power lines or motor leads.

Standard convertible sensors, insertion sensors, and sanitary sensors have cable permanently attached to the sensor. This cable contains double shielded conductors to minimize noise problems in heavy industrial environments. Convertible sensors with connectors and flow type sensors use a slightly different cable assembly with only a single shield. This assembly is sufficient for many applications where EMI/RFI problems are not severe. Figure 21 and Figure 22 show the two different cable assembly terminations.

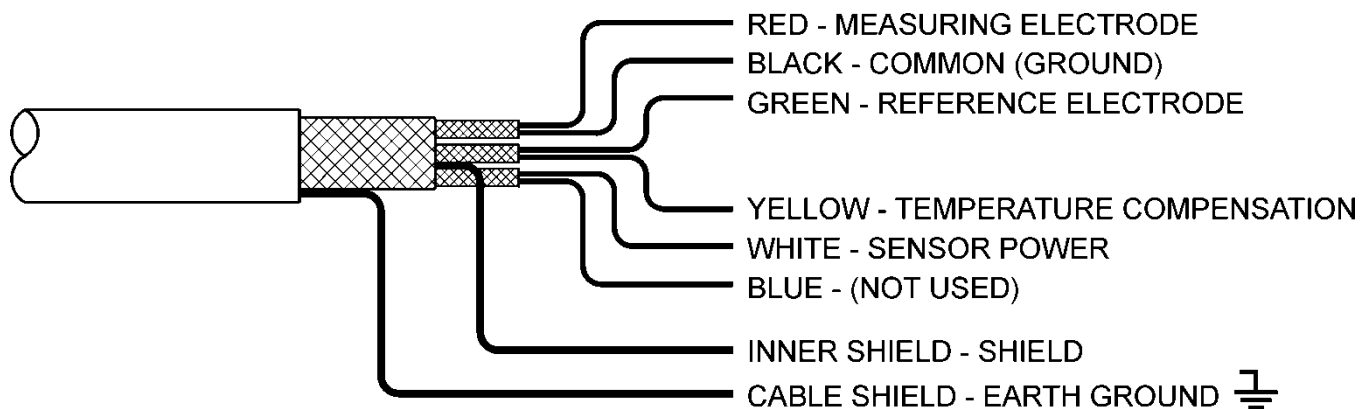

Figure 21 - Cable Description, Model Q25P

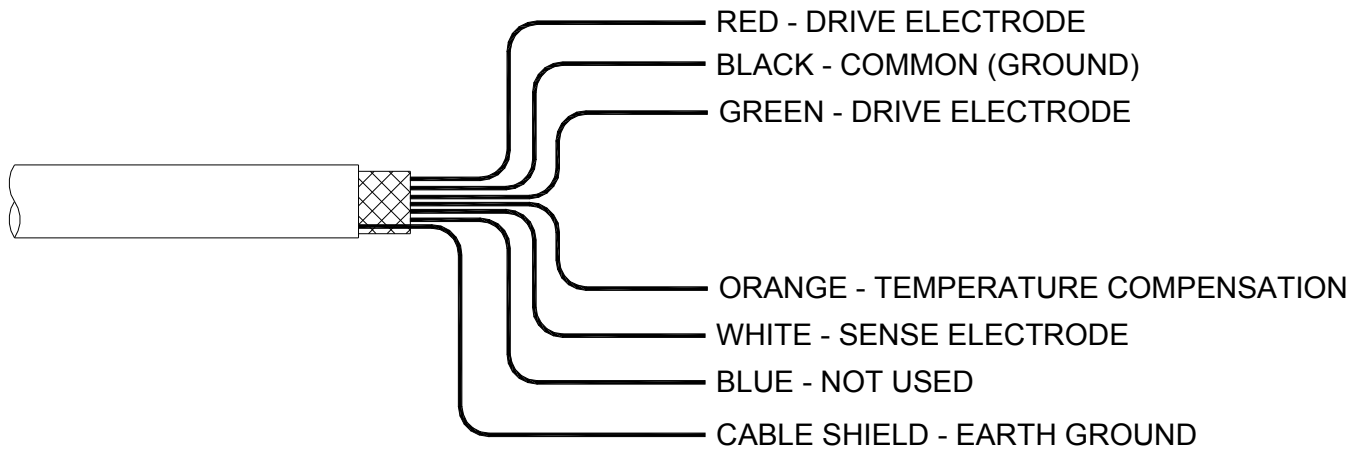

Figure 22 - Detachable Single Shielded Cable, Model Q25P



DANGER: DO NOT connect sensor cable to power lines. Serious injury may result.

Take care to route sensor cable away from AC power lines, adjustable frequency drives, motors, or other noisy electrical signal lines. Do not run signal lines in the same conduit as AC power lines. Run signal cable in dedicated metal conduit if possible. For optimum electrical noise protection, run an earth ground wire to the ground terminal in the transmitter.

NOTE: If sensor is experiencing Low-Slope or Low-Output conditions, due to poor Earth Ground Connections, move the Shield connection from P/S Board to alternate location on lid, where indicated with an “S”

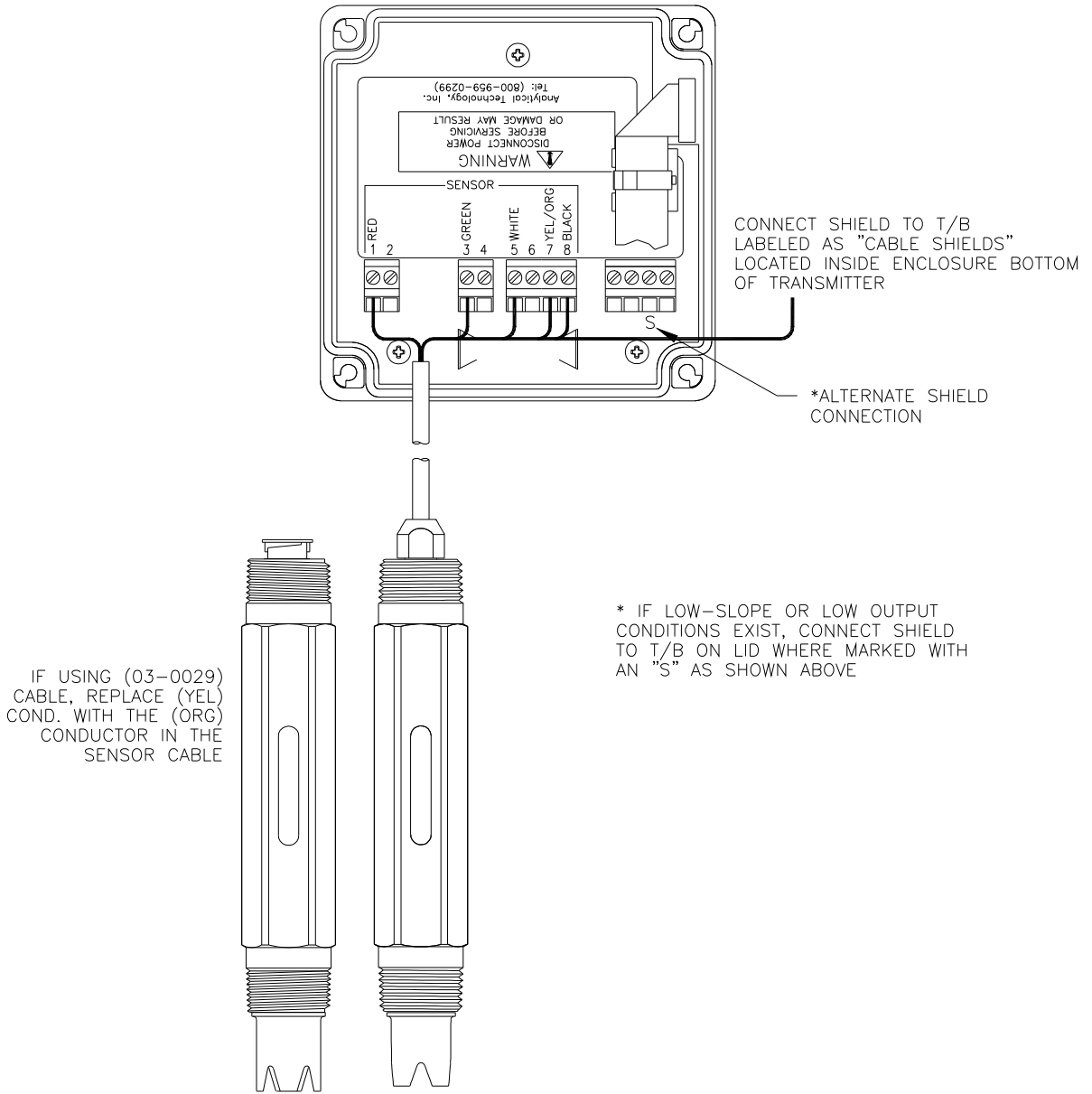

Figure 23 - Q46P Sensor Connections

4.6 Direct Sensor Connection

Sensor connections are made in accordance with Figure 23. The sensor cable can be routed into the enclosure through one of cord-grips supplied with the unit. Routing sensor wiring through conduit is only recommended if a junction box is to be used. Some loose cable is needed near the installation point so that the sensor can be inserted and removed easily from the flowcell.

Cord-grips used for sealing the cable should be snugly tightened after electrical connections have been made to prevent moisture incursion. When stripping cables, leave adequate length for connections in the transmitter enclosure as shown below. The standard 15 ft. sensor cable normally supplied with the system is already stripped and ready for wiring. This cable can be cut to a shorter length if desired to remove extra cable in a given installation. Do not cut the cable so short as to make installation and removal of the sensor difficult.

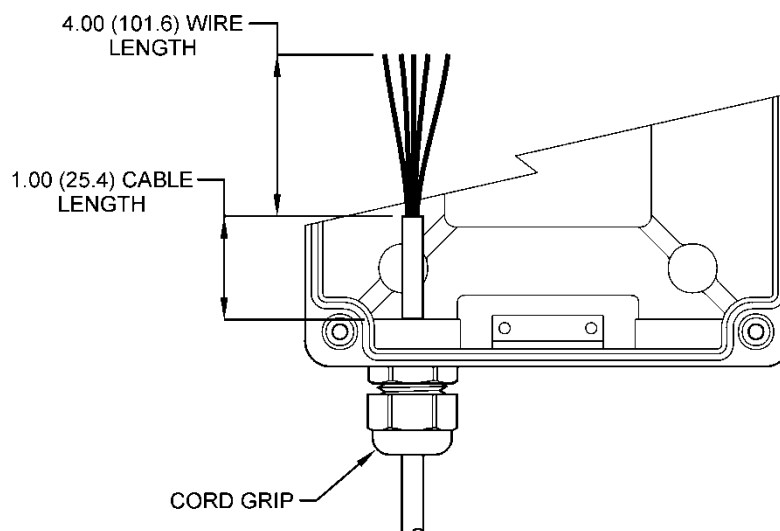

Figure 24 - Sensor Cable Preparation

4.7 Junction Box Connection

For installations where the sensor is to be located more than 30 feet from the monitor (max. 3000 feet), a junction box must be used. The junction box is shown in Figure 25, and is supplied with Pg 9 gland seals for sensor and interconnect wiring installation.

NOTE: If sensor is experiencing Low-Slope or Low-Output conditions, due to poor Earth Ground Connections, move the Shield connection from P/S board to alternate location on lid, where indicated with an “S”.

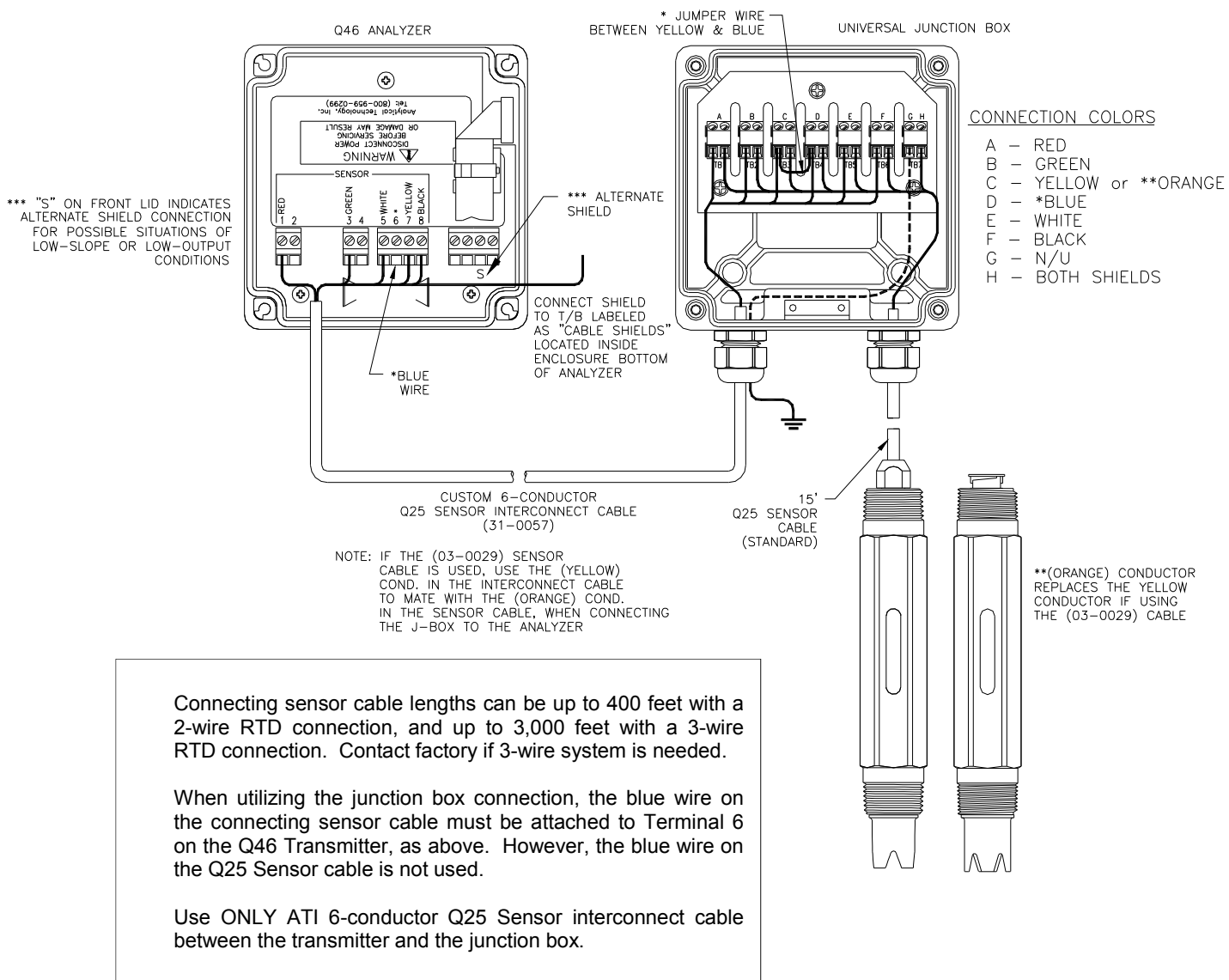

Figure 25 - Junction Box Interconnect Wiring

4.8 Combination Electrode Connection

The Q46P may also be used with non-amplified simple combination electrodes (see Figure 26). Note that a wire jumper must be installed from Terminal 3 to Terminal 8. The user must also select Sensor Type 2 within the Config Menu (see Section 5.24). The maximum sensor-to-instrument cable length will be severely limited (30-50 feet) with electrodes of this type. The length will depend on the specific electrode impedance and the quality of interconnect cable provided by the manufacturer.

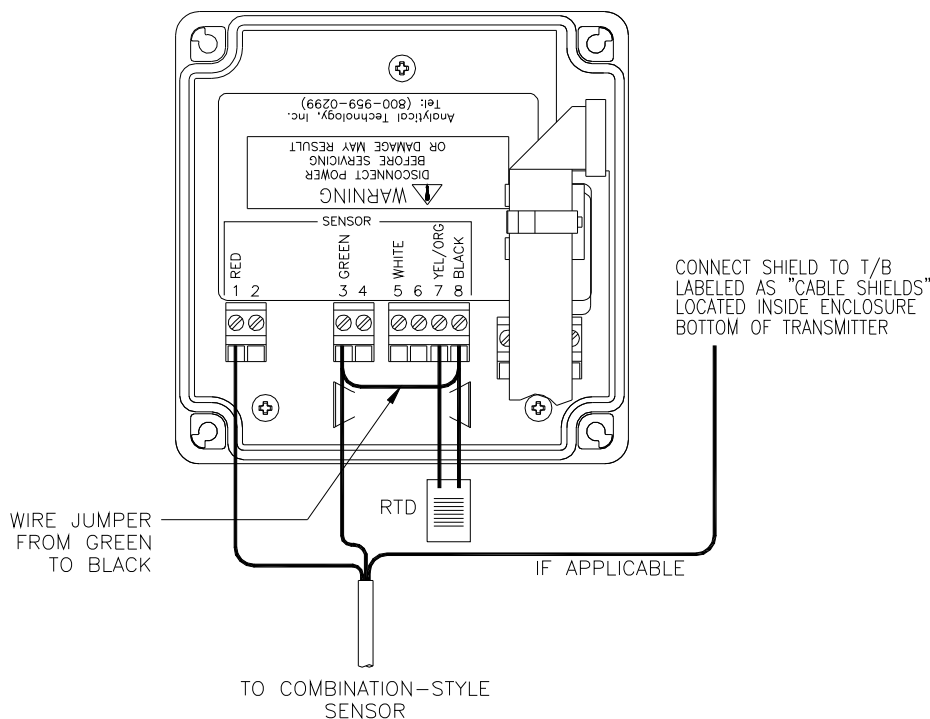
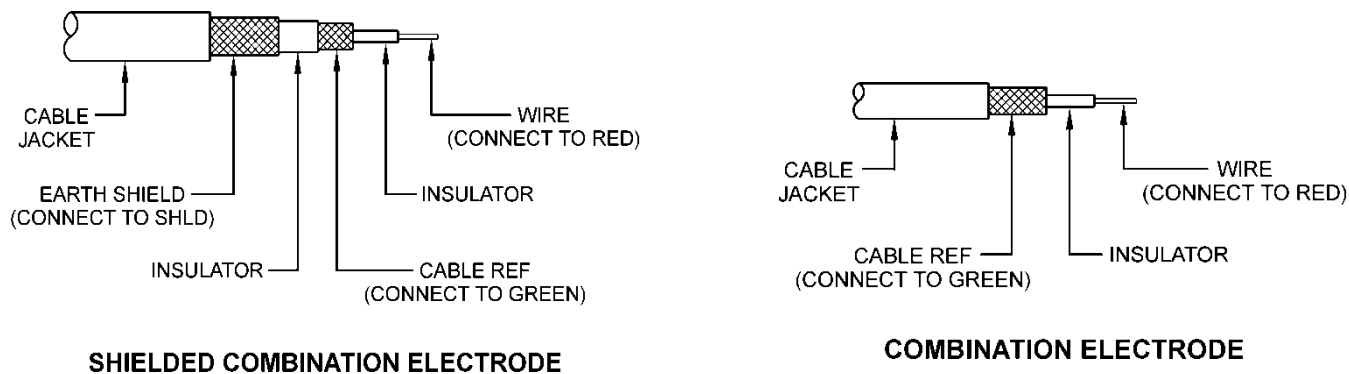
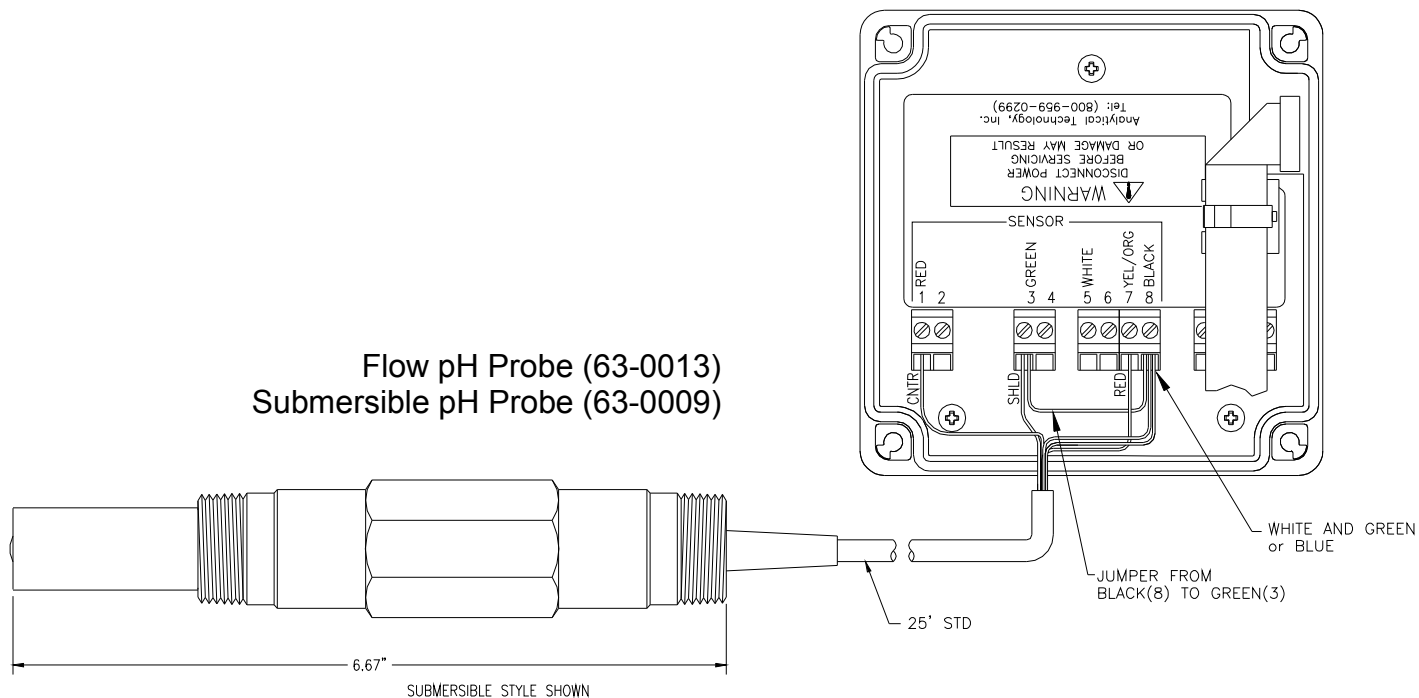

Figure 26 – OEM Sensor Connections, Combination Electrodes



Connect ATI sensors listed above as follows:

- Terminal 1 – Center clear (coax)
- 3 – Shield (coax)
- 7 – Red (Pt100)
- 8 – White and Green or Blue (Pt100)

Terminals 3 & 8 **MUST** be connected with a jumper wire

For Other Combination Electrodes connect as follows:

- Terminal 1- Glass Electrode
- 3 - Reference Electrode
- 7 - PT100 or PT1000 Temp. Element
- 8 - PT100 or PT1000 Temp Element

Terminals 3 and 8 **MUST** be connected with jumper wire.

Figure 27 – ATI Combination Electrode Connections

4.9 External Preamplifier

An external preamplifier (part no. 00-1391) is available which allows the use of conventional pH sensors long distances from the Q46P electronics. This preamp is housed in a NEMA 4X enclosure and must be located within 25 ft. of the pH sensor. It is critical that any conduit entry installed in this enclosure be completely sealed. Moisture entering the enclosure through a conduit will cause failure of the amplifier circuit. Use of this preamp. allows the Q46P to be located up to 300 metres from the sensor/preamp. installation location. Wiring for that system is shown below.

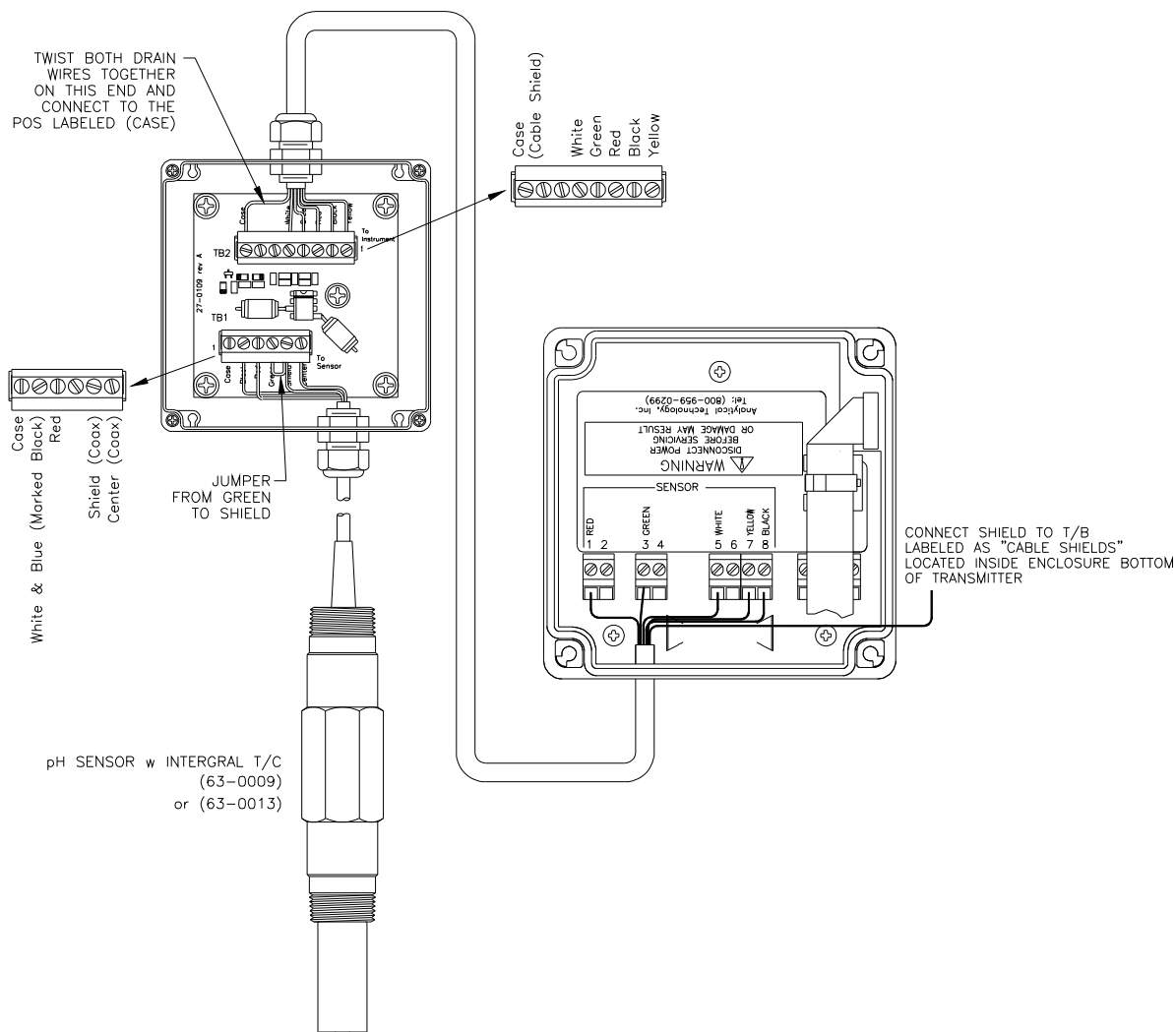

Figure 28 - External Preamp for Conventional Sensor Wiring

Part 5 – Configuration

5.1 User Interface

The user interface for the Q46 Series instrument consists of a custom display and a membrane keypad. All functions are accessed from this user interface (no internal jumpers, pots, etc.).

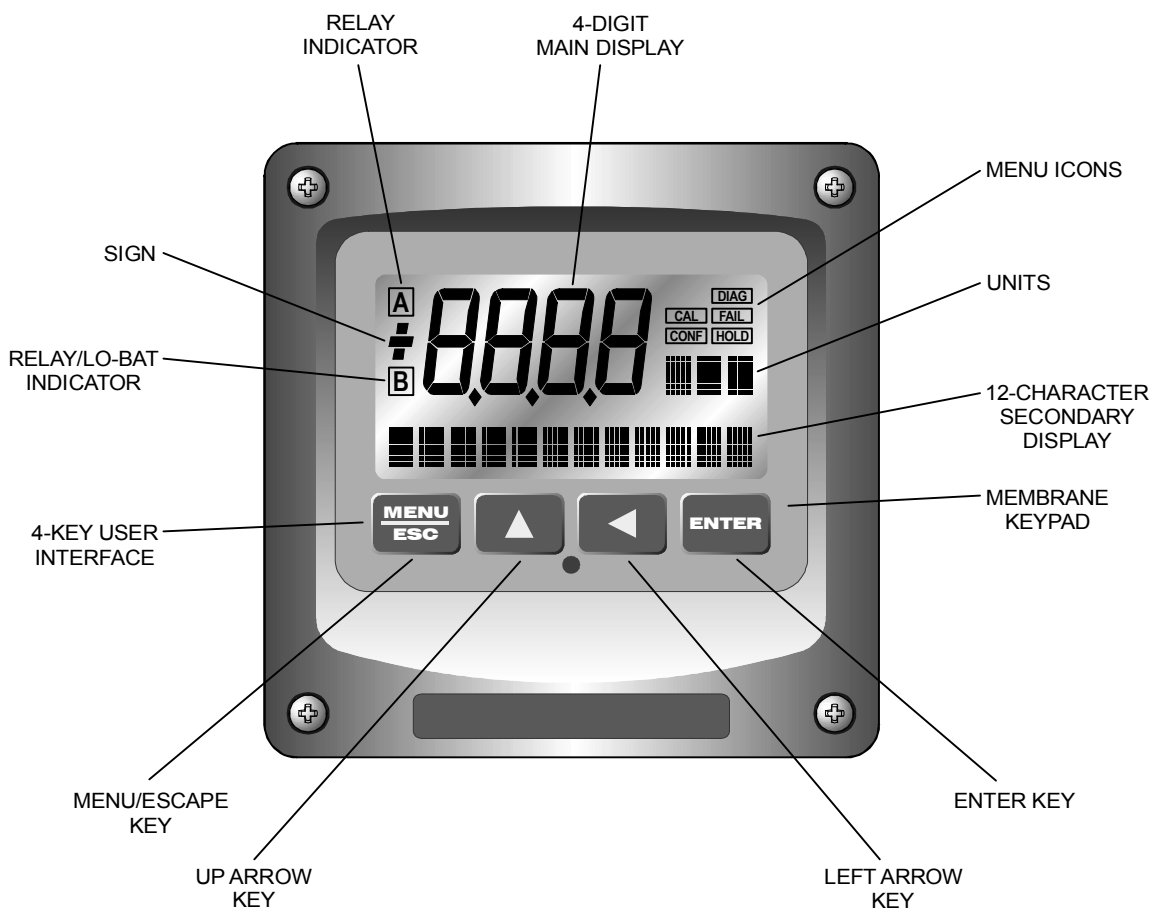

Figure 29 - User Interface

5.11 Keys

All user configurations occur through the use of four membrane keys. These keys are used as follows:

- | | |
|---------------------|----------------------------------------------------------------------------------------------------------------------------------------------------------------------------------------------------------------------------------------------------------------------------------------------------------------------------------------------------------------------------------------------|
| MENU/ESC | To scroll through the menu section headers or to escape from anywhere in software. The escape sequence allows the user to back out of any changes in a logical manner. Using the escape key aborts all changes to the current screen and backs the user out one level in the software tree. The manual will refer to this key as either MENU or ESC, depending upon its particular function. |
| UP (arrow) | To scroll through individual list or display items and to change number values. |
| LEFT (arrow) | To move the cursor from right to left during changes to a number value. |
| ENTER | To select a menu section or list item for change and to store any change. |

5.12 Display

The large custom display provides clear information for general measurement use and user configuration. There are three main areas of the display: the main parameter display, the secondary message line, and the icon area.

Main Parameter During normal operation, the main parameter display indicates the present process input with sign and units. This main display may be configured to display any of the main measurements that the system provides. During configuration, this area displays other useful set-up information to the user.



Lower Line During normal operation, the lower line of the display indicates user-selected secondary measurements that the system is making. This also includes calibration data from the last calibration sequence and the transmitter model number and software version. During configuration, the lower line displays menu items and set-up prompts to the user. Finally, the lower line will display error messages when necessary. For a description of all display messages, refer to Section 8.3.



Icon Area The icon area contains display icons that assist the user in set-up and indicate important states of system functions. The CAL, CONFIG, and DIAG icons are used to tell the user what branch of the software tree the user is in while scrolling through the menu items. This improves software map navigation dramatically. Upon entry into a menu, the title is displayed (such as CAL), and then the title disappears to make way for the actual menu item. However, the icon stays on.



HOLD The HOLD icon indicates that the current output of the transmitter has been put into output hold. In this case, the output is locked to the last input value measured when the HOLD function was entered. HOLD values are retained even if the unit power is cycled.

FAIL The FAIL icon indicates that the system diagnostic function has detected a problem that requires immediate attention. This icon is automatically cleared once the problem has been resolved.

Relay Area A/B

The relay area contains two icons that indicate the state of the system relays. Relay C is normally configured for FAIL indication, so it is only displayed on the lower MEASURE display line.

**5.2 Software**

The software of the Q46P is organized in an easy to follow menu-based system. All user settings are organized under five menu sections: Measure, Calibration [CAL], Configuration [CONFIG], Control [CONTROL] and Diagnostics [DIAG].

Note: The default Measure Menu is display-only and has no menu icon.

5.2.1 Software Navigation

Within the CAL, CONFIG, CONTROL, and DIAG menu sections is a list of selectable items. Once a menu section (such as CONFIG) has been selected with the MENU key, the user can access the item list in this section by pressing either the ENTER key or the UP arrow key. The list items can then be scrolled through using the UP arrow key. Once the last item is reached, the list wraps around and the first list item is shown again. The items in the menu sections are organized such that more frequently used functions are first, while more permanent function settings are later in the list. See Figure 30 for a visual description of the software.

Each list item allows a change to a stored system variable. List items are designed in one of two forms: simple single variable, or multiple variable sequence. In the single variable format, the user can quickly modify one parameter - for example, changing temperature display units from °F to °C. In the multiple variable sequence, variables are changed as the result of some process. For example, the calibration of pH generally requires more than one piece of information to be entered. The majority of the menu items in the software consist of the single variable format type.

Any data that may be changed will be flashing. This flashing indicates user entry mode and is initiated by pressing the ENTER key. The UP arrow key will increase a flashing digit from 0 to 9. The LEFT arrow key moves the flashing digit from right to left. Once the change has been completed, pressing ENTER again stores the variable and stops the flashing. Pressing ESC aborts the change and also exits user entry mode.

The starting (default) screen is always the Measure Menu. The UP arrow key is used to select the desired display. From anywhere in this section the user can press the MENU key to select one of the four Menu Sections.

The UP arrow icon next to all list items on the display is a reminder to scroll through the list using the UP arrow key.

To select a list item for modification, first select the proper menu with the MENU key. Scroll to the list item with the UP arrow key and then press the ENTER key. This tells the system that the user wishes to perform a change on that item. For single item type screens, once the user presses the ENTER key, part or all of the variable will begin to flash, indicating that the user may modify that variable using the arrow keys. However, if the instrument is locked, the transmitter will display the message **Locked!** and will not enter user entry mode. The instrument must be unlocked by entering the proper code value to allow authorized changes to user entered values. Once the variable has been reset, pressing the ENTER key again causes the change to be stored and the flashing to stop. The message **Accepted!** will be displayed if the change is within pre-defined variable limits. If the user decides not to modify the value after it has already been partially changed, pressing the ESC key aborts the modification and returns the entry to its original stored value.

In a menu item which is a multiple variable sequence type, once the ENTER key is pressed there may be several prompts and sequences that are run to complete the modification. The ESC key can always be used to abort the sequence without changing any stored variables.

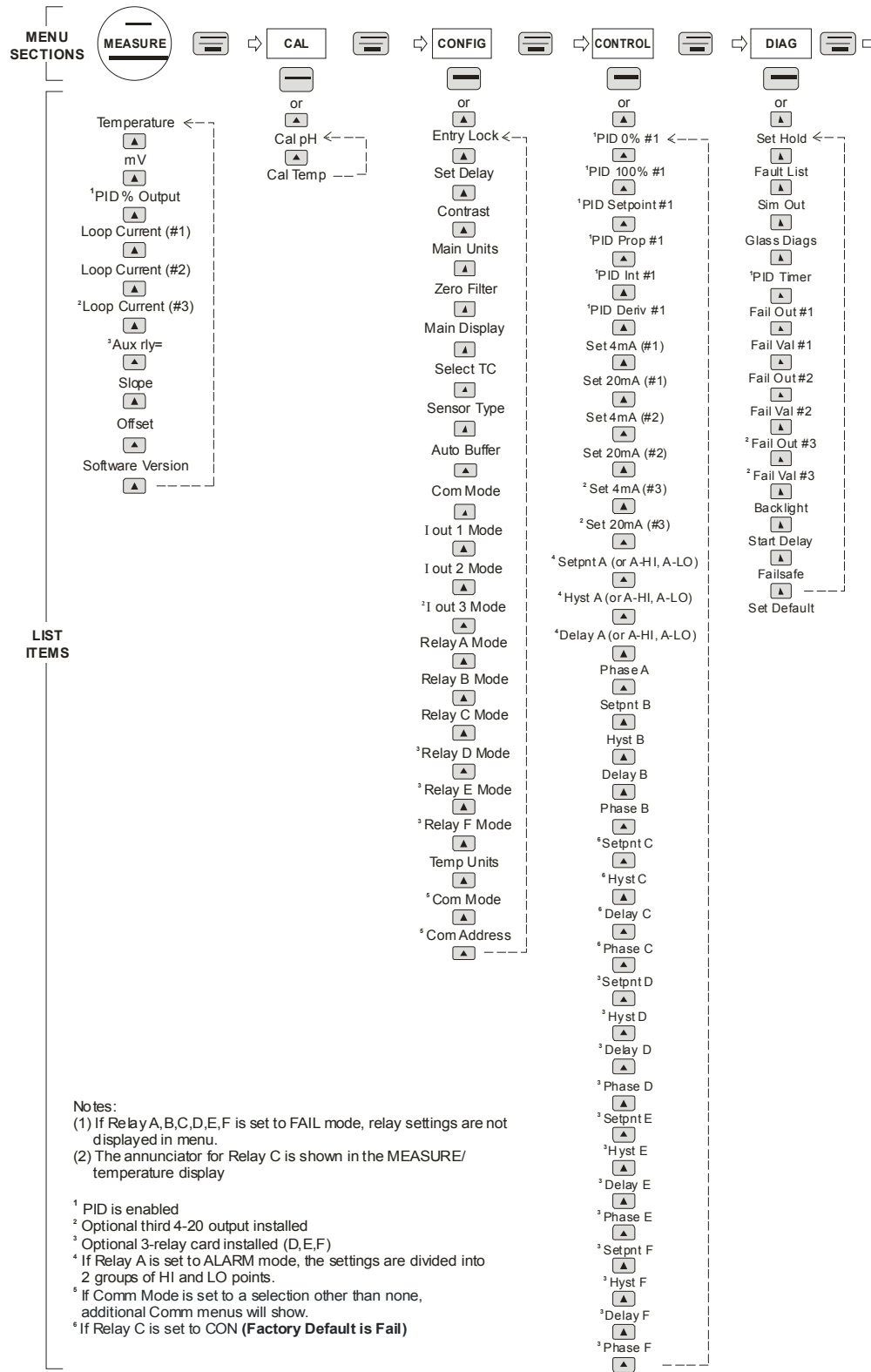

Figure 30 - Software Map

5.22 Measure Menu [MEASURE]

The default menu for the system is the display-only menu MEASURE. This menu is a display-only measurement menu, and has no changeable list items. When left alone, the instrument will automatically return to this menu after approximately 30 minutes. While in the default menu, the UP arrow allows the user to scroll through the secondary variables on the lower line of the display. A brief description of the fields in the basic transmitter version is as follows:

TRANSMITTER MEAS SCREENS:

25.7°	Temperature display. Can be displayed in °C or °F, depending on user selection. A small “m” on the left side of the screen indicates the transmitter has automatically jumped to a manual 25°C setting due to a failure with the temperature signal input.
+132 mV	Raw sensor voltage. Useful for diagnosing problems.
100% 20.00 mA	PID Status screen (if enabled.) Shows the present controller output level on left, and actual analyzer current on the right. The controller can be placed in manual while viewing this screen by pressing and holding the ENTER key for 5 seconds until a small flashing “m” appears on the screen. At that point the controller output can be adjusted up or down using the UP and LEFT arrow keys. To return to automatic operation, press and hold the ENTER key for 5 seconds and the “M” will disappear.
#1 4.00 mA	Analyzer output current # 1.
#2 12.00 mA	Analyzer output current # 2.
#3 20.00 mA	Analyzer output current # 3 (if option included.)
Aux relay=D,E,F	Auxilliary relay annunciators (if option included.)
Slope = 100%	Sensor output response vs. ideal calibration. This value updates after each calibration. As the sensor ages, the slope reading will decay indicating sensor aging. Useful for resolving sensor problems.

Offset = 0.0 mV Sensor output current at a zero ppm input. This value updates after a zero-calibration has been performed. Useful for resolving sensor problems.

Q46P v4.01 Transmitter software version number.

Toff 0.9mn Auto-Clean status screen (if enabled)

Note: A display test (all segments ON) can be actuated by pressing and holding the ENTER key while viewing the model/version number on the lower line of the display.

The MEASURE screens are intended to be used as a very quick means of looking up critical values during operation or troubleshooting.

5.23 Calibration Menu [CAL]

The calibration menu contains items for frequent calibration of user parameters. There are two items in this list: Cal pH and Cal Temp.

Cal pH The pH calibration function allows the user to adjust the transmitter offset and span reading to match reference buffers, or to adjust the sensor offset to match the sample reading. See Part 6 - Calibration for more details.

Cal Temp The temperature calibration function allows the user to adjust the offset of the temperature response by a small factor of ± 5 °C. The temperature input is factory calibrated to very high accuracy. However, long cable lengths and junction boxes may degrade the accuracy of the temperature measurement in some extreme situations. Therefore, this feature is provided as an adjustment. See Part 6 - Calibration for more details.

5.24 Configuration Menu [CONFIG]

The Configuration Menu contains all of the general user settings:

Entry Lock

This function allows the user to lock out unauthorized tampering with instrument settings. All settings may be viewed while the instrument is locked, but they cannot be modified. The Entry Lock feature is a toggle-type setting; that is, entering the correct code will lock the transmitter and entering the correct code again will unlock it. The code is preset at a fixed value. Press ENTER to initiate user entry mode and the first digit will flash. Use arrow keys to modify value. **See the last page of this manual for the Q46P lock/unlock code.** Press ENTER to toggle lock setting once code is correct. Incorrect codes do not change state of lock condition.

Set Delay

The delay function sets the amount of damping on the instrument. This function allows the user to apply a first order time delay function to the pH measurements being made. Both the display and the output value are affected by the degree of damping. Functions such as calibration are not affected by this parameter. The calibration routines contain their own filtering and stability monitoring functions to minimize the calibration timing. Press ENTER to initiate user entry mode, and the value will flash. Use the arrow keys to modify value; range is 0.1 to 9.9 minutes. Press ENTER to store the new value.

Contrast

This function sets the contrast level for the display. The custom display is designed with a wide temperature range, Super-Twist Nematic (STN) fluid.

The STN display provides the highest possible contrast and widest viewing angle under all conditions. Contrast control of this type of display is generally not necessary, so contrast control is provided as a means for possible adjustment due to aging at extreme ranges. In addition, the display has an automatic temperature compensation network. Press ENTER to initiate user entry mode, and the value will flash. Use arrow keys to modify the value; range is 0 to 8 (0 being lightest). Press ENTER to update and store the new value.

- Main Display** This function allows the user to change the measurement in the primary display area. The user may select between pH, sensor temperature, or output current. Using this function, the user may choose to put temperature in the main display area and pH on the secondary, lower line of the display. Press ENTER to initiate user entry mode, and the entire value will flash. Use the UP arrow key to modify the desired display value. Press ENTER to store the new value.
- Com Mode** Sets digital communication mode of analyzer. Optional digital communication card must be plugged into the power supply slot for this function to work. Press ENTER to initiate user entry mode, and the entire value will flash. Use the UP arrow key to modify the desired value; selections include 1- Modb for Modbus, 2- P-DP for Profibus DP. Press ENTER to store the new value.
- Com Address** Sets bus address for digital communication mode of analyzer. Optional digital communication card must be plugged into the power supply slot for this function to work.
- Press ENTER to initiate user entry mode, and the entire value will flash. Use the UP arrow key to modify the desired value. Range is 1-125. Press ENTER to store the new value.
- Select TC** This function allows the user to select either a Pt1000 or a Pt100 RTD temperature element. The Pt1000 element is the standard element in all high performance Q25 sensors; it is the recommended temperature sensing element for all measurements. The Pt100 selection is provided as an alternative for use with existing combination-style sensors. Press ENTER to initiate user entry mode, and the entire value will flash. Use the UP arrow key to modify the desired value. Press ENTER to store the new value.
- Sensor Type** This function sets the sensor input type. This selection is critical for control of the internal diagnostics and compensation factors. Press ENTER to initiate user entry mode, and the entire value will flash. Use the UP arrow key to modify the desired value. Selections are **1** for Q25P glass sensor, **2** for combination electrode, **3** for Q25P antimony electrode, and **4** for pure water sensor using special compensation table. Press ENTER to store the new value.

Auto Buffer

This is a multiple variable function that allows the user to choose which pH buffer sets that will be utilized in the 2-point calibration mode. The Q46P contains 3 sets of built-in buffer tables with compensation values ranging from 0 to 95°C. During 2-point calibration, the instrument will automatically identify which buffer is being used and compensate for the value based on the built-in tables. This allows very quick, highly accurate calibrations by the user. The order in which the buffers are used during calibration is unimportant, since the system automatically chooses the correct buffer.

The default setting for this feature is **OFF**, which disables the auto-recognition function. Press ENTER to change this setting. The buffer table set options are: 1: [4/7/10], 2: [4/7/9.18], and 3: [4.65/6.79/9.23]. See Figure 32 for buffer tables. Once the buffer set is selected, press ENTER and the message **Accepted!** will be displayed on the lower line.

Table 1

4.00 pH		7.00 pH		10.00 pH	
°C	pH	°C	pH	°C	pH
0	4.00	0	7.10	0	10.27
10	3.99	10	7.06	10	10.15
20	4.00	20	7.02	20	10.05
30	4.01	30	6.99	30	9.95
40	4.03	40	6.97	40	9.87
50	4.05	50	6.98	50	9.80
60	4.08	60	6.98	60	9.75
70	4.12	70	6.97	70	9.73
80	4.16	80	6.99	80	9.73
90	4.21	90	7.01	90	9.75
95	4.24	95	7.01	95	9.77

Table 2

4.00 pH		7.00 pH		9.18 pH	
°C	pH	°C	pH	°C	pH
0	4.00	0	7.10	0	9.46
10	3.99	10	7.06	10	9.33
20	4.00	20	7.02	20	9.23
30	4.01	30	6.99	30	9.14
40	4.03	40	6.97	40	9.07
50	4.05	50	6.98	50	9.01
60	4.08	60	6.98	60	8.96
70	4.12	70	6.97	70	8.92
80	4.16	80	6.99	80	8.89
90	4.21	90	7.01	90	8.85
95	4.24	95	7.01	95	8.83

Figure 31 - Automatic pH Buffer Tables

Table 3

4.65 pH		6.79 pH		9.23 pH	
°C	pH	°C	pH	°C	pH
0	4.67	0	6.89	0	9.48
10	4.66	10	6.84	10	9.37
20	4.65	20	6.80	20	9.27
30	4.65	30	6.78	30	9.18
40	4.66	40	6.76	40	9.09
50	4.68	50	6.76	50	9.00
60	4.70	60	6.76	60	8.92
70	4.72	70	6.76	70	8.88
80	4.75	80	6.78	80	8.85
90	4.79	90	6.80	90	8.82
95	4.79	95	6.80	95	8.82

Figure 32 - Buffer Tables (Cont'd)

Automatic pH

lout#1 Mode

This function sets analog output #1 to either track pH (default) or enables the PID controller to operate on the pH input. Press ENTER to initiate user entry mode, and the entire value will flash. Use the UP arrow key to modify the desired value; selections include 1-pH, 2-PID for PID output. Press ENTER to store the new value.

lout#2 Mode

This function sets analog output #2 for temperature (default), or pH. Press ENTER to initiate user entry mode, and the entire value will flash. Use the UP arrow key to modify the desired value; selections include 1-C/F for temperature, 2-pH for pH. Press ENTER to store the new value.

***lout#3 Mode**

OPTIONAL. This function sets analog output #3 for temperature or pH. Press ENTER to initiate user entry mode, and the entire value will flash. Use the UP arrow key to modify the desired value; selections include 1-C/F for temperature, 2-pH for pH. Press ENTER to store the new value.

Rly A Mode

Relay A can be used in three different ways: as a setpoint control, as a fail alarm, or as a HI-LO alarm band. The three settings for Rly A Mode are **CON**, **FAIL** and **AL**.

The **CON** setting enables normal control operation for Relay A, with settings for setpoint, hysteresis, delay and phasing appearing in the CONFIG menu automatically. See Figure 33 for further details.

The **FAIL** setting enables the fail alarm mode for Relay A. Relay A will then trip on any condition that causes the FAIL icon to be displayed on the LCD. Using this mode allows the User to send alarm indications to other remote devices.

The **AL** setting allows two setpoints to be selected for the same relay, producing a HI-LO alarm band. In this mode, Relay A will trip inside or outside of the band, depending upon the Phase selected. See Figure 34 for further details.

***Relay B Mode**

Relay B can be used in a number of ways: as a setpoint control, as an alarm, or as an auto-cleaner. The four settings for Relay B Mode are **CON**, **FAIL**, **CLn1**, and **CLn2**.

The **CON** setting enables normal setpoint operation for Relay B. Relay B then operates identically to Relay A, with settings for setpoint, hysteresis, delay and phasing appearing in the CONFIG menu automatically. See Figure 33 for details.

The **FAIL** setting enables the fail alarm mode for Relay B. Relay B will then trip on any condition that causes the FAIL icon to be displayed on the LCD. Using this mode allows the User to send alarm indications to other remote devices. Figure 34 for details.

Relay B in Auto-Clean Monitors is used to activate the air-wash cleaning system that keeps the sensor operating properly. This relay should normally be set to **CLn1 1** Mode for normal cleaning. Do not change the factory setting for this relay without first consulting ATI or your ATI representative

Relay C Mode

Relay B and C can be used in two ways: as a setpoint control, or as an alarm. The two settings for Relay B Mode are **CON** and **FAIL**.

The **CON** setting enables normal setpoint operation for Relay B/C. Relay B/C then operates identically to Relay A, with settings for setpoint, hysteresis, delay and phasing appearing in the CONFIG menu automatically. See Figure 33 for details.

The **FAIL** setting enables the fail alarm mode for Relay B/C. Relay B/C will then trip on any condition that causes the FAIL icon to be displayed on the LCD. Note that the Relay C indicator shows up only on the lower screen of the display next to the temperature reading. This is because the default setting for relay C is the **FAIL** setting. Using this mode allows the User to send alarm indications to other remote devices. See Figure 34 for details.

Relay D Mode**Relay E Mode*****Relay F Mode**

OPTIONAL. Relays D, E, and F can be used in two ways: as a setpoint control, or as an alarm. The two settings for Relay B Mode are **CON** and **FAIL**.

The **CON** setting enables normal setpoint operation for Relay B. Relay B then operates identically to Relay A, with settings for setpoint, hysteresis, delay and phasing appearing in the CONFIG menu automatically. See Figure 33 for details.

Temp Units

This function sets the display units for temperature measurement. Press ENTER to initiate user entry mode, and the entire value will flash.

Use the UP arrow key to modify the desired display value. The choices are °F and °C. Press ENTER to store the new value.

5.25 Control Menu [CONTROL]

The Control Menu contains all of the output control user settings:

Set PID 0%

Set PID 100%

[lout1=PID]

If the PID is enabled, this function sets the minimum and maximum controller end points. Unlike the standard 4-20 mA output, the controller does not “scale” output values across the endpoints. Rather, the endpoints determine where the controller would normally force minimum or maximum output in an attempt to recover the setpoint (even though the controller can achieve 0% or 100% anywhere within the range.)

If the 0% point is lower than the 100% point, then the controller action will be “reverse” acting. That is, the output of the controller will increase if the measured value is less than the setpoint, and the output will decrease if the measured value is larger than the setpoint. Flipping the stored values in these points will reverse the action of the controller to “direct” mode.

The entry value is limited to a value within the range specified in “Set Range”, and the 0% and the 100% point must be separated by at least 1% of this range. Use the LEFT arrow key to select the first digit to be modified. Then use the UP and LEFT arrow keys to select the desired numerical value. Press ENTER to store the new value.

PID Setpnt

[lout1=PID]

The measured value which the controller is attempting to maintain by adjusting output value. It is the nature of the PID controller that it never actually gets to the exact value and stops. The controller is continually making smaller and smaller adjustments as the measured value gets near the setpoint.

PID Prop

[lout1=PID]

Proportional gain factor. The proportional gain value is a multiplier on the controller error (difference between measured value and setpoint value.) Increasing this value will make the controller more responsive.

PID Int

[lout1=PID]

Integral is the number of “repeats-per-minute” of the action of the controller. It is the number of times per minute that the controller acts on the input error. At a setting of 2.0 rpm, there are two repeats every minute. If the integral is set to zero, a fixed offset value is added to the controller (manual reset.) Increasing this value will make the controller more responsive.

PID Deriv

[lout1=PID]

Derivative is a second order implementation of Integral, used to suppress “second-order” effects from process variables. These variables may include items like pumps or mixers that may have minor impacts on the measured value. The derivative factor is rarely used in water treatment process, and therefore, it is best in most cases to leave it at the default value. Increasing this value will make the controller more responsive.

Set 4 mA**Set 20 mA**

[lout1=pH]

These functions set the main 4 and 20 mA current loop #1 output points for the analyzer when output 1 is in normal, non-PID, mode of operation.

The value stored for the 4 mA point may be higher or lower than the value stored for the 20 mA point. The entry values are limited to values within the range specified in “Set Range”, and the 4 mA and the 20 mA point must be separated by at least 1% of this range. Use the LEFT arrow key to select the first digit to be modified. Then use the UP and LEFT arrow keys to select the desired numerical value. Press ENTER to store the new value.

***Set 4 mA #2**
***Set 20 mA #2**
[temp/pH]

These functions set the second 4 mA and 20 mA current loop output points for the transmitter. The output may be set to track temperature (default) or pH. The values stored for the 4 mA point may be higher or lower than the value stored for the 20 mA point.

The entry value is limited to a value between 0 and 55 °C if it is set for temperature and must be within 0-14 pH if set to track pH. The 4 mA and the 20 mA point must be at least 20 units away from each other. Press ENTER to initiate user entry mode, and the value will flash. Use arrow keys to modify value. Press ENTER to store the new value.

***Set 4 mA #3**
***Set 20 mA #3**
[temp/pH]

OPTIONAL These functions set the optional third 4 mA and 20 mA current loop output points for the transmitter. The output may be set to track temperature (default) or pH. The values stored for the 4 mA point may be higher or lower than the value stored for the 20 mA point.

The entry value is limited to a value between 0 and 55 °C if it is set for temperature and must be within 0-14 pH if set to track pH. The 4 mA and the 20 mA point must be at least 20 units away from each other. Press ENTER to initiate user entry mode, and the value will flash. Use arrow keys to modify value. Press ENTER to store the new value.

***A Setpoint**

This function establishes the pH trip point for relay A. The entry value is limited to a value within the range specified in "Set Range". Use the LEFT arrow key to select the first digit to be modified. Then use the UP and LEFT arrow keys to select the desired numerical value. Press ENTER to store the new value.

- *A Hysteresis** This function establishes the hysteresis, or “deadband”, for Relay A. Hysteresis is most often used to control relay chattering; however, it may also be used in control schemes to separate the ON/OFF trip points of the relay. Press ENTER to initiate user entry mode, and the value will flash. Use the arrow keys to modify value. Press ENTER to store the new value.
- *A Delay** This function places an additional amount of time delay on the trip point for relay A. This delay is in addition to the main delay setting for the controller. The entry value is limited to a value between 0 and 999 seconds. Press ENTER to initiate user entry mode, and the value will flash. Use arrow keys to modify value; range is 0 to 999 seconds. Press ENTER to store the new value.
- *A Phasing** This function establishes the direction of the relay trip. When phase is HI, the relay operates in a direct mode. Therefore, the relay energizes and the LCD indicator illuminates when the pH value **exceeds** the setpoint. When the phase is LO, the relay energizes and the LCD indicator illuminates when the pH level drops **below** the setpoint. The failsafe setting does have an impact on this logic. The description here assumes the failsafe setting is OFF. Press ENTER to initiate user entry mode, and the entire value will flash. Use the UP arrow key to modify the desired value; selections include **HI** for direct operation or **LO** for reverse operation. Press ENTER to store the new value.

See Figure 33 below for a visual description of a typical control relay application.

When value rises to ≥ 9.00 pH, relay closes.

When value falls to ≤ 8.95 pH, relay opens.

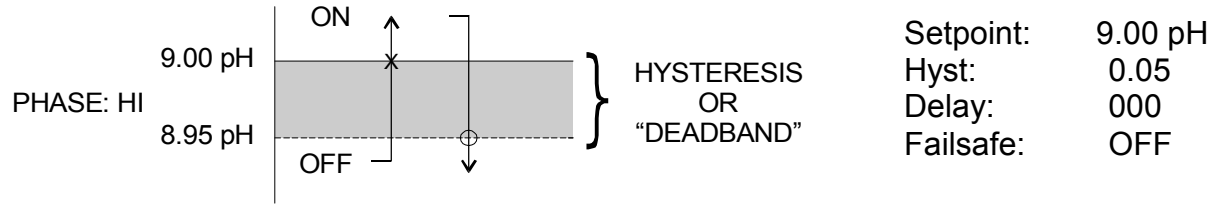

When value rises to ≥ 9.05 pH, relay opens.

When value falls to ≤ 9.00 pH, relay closes.

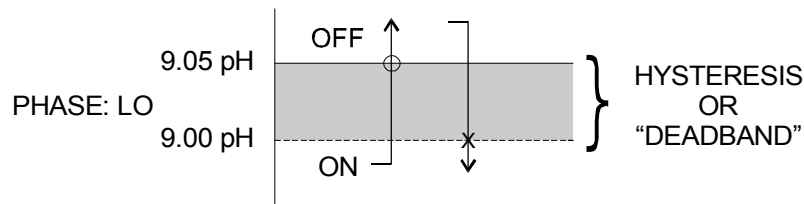

Figure 33 - Control Relay Example, Hysteresis and Opposite Phase

- *Setpnt A-HI
- *Hyst A-HI
- *Delay A-HI
- *Setpnt A-LO
- *Hyst A-LO
- *Delay A-LO

If Relay A Mode is set to Alarm Mode, **AL**, then the following settings will appear in the Config Menu list automatically. In this mode, two setpoints can be selected on the same relay, to create an alarm band. Phase HI selection causes the relay to energize outside of the band, and Phase LO causes the relay to energize inside of the band. This feature enables one relay to be used as a control relay while the other is used as a HI-LO Alarm relay at the same time. Setpoint A-LO must be set lower than Setpoint A-HI. When AL mode is first selected, Setpoint A-LO is defaulted to 0.

Figure 34 is a visual description of a typical alarm relay application.

When value rises to ≥ 9.00 pH, relay closes, until value falls back to ≤ 8.95

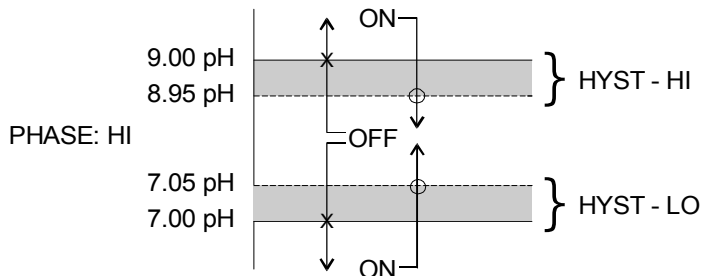

SetpointA-HI: 9.00 pH
 Hyst A-HI: 0.050
 Delay A-HI: 000

When value falls to ≤ 9.00 pH, relay closes, until rises back to ≥ 9.05 pH.

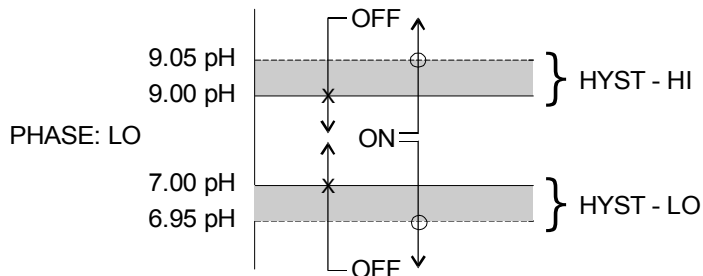

Setpoint A-LO: 7.00 pH
 Hyst A-LO: 0.05 pH
 Delay A-LO: 000

When value falls to ≤ 7.00 pH, relay closes, until value rises back to ≥ 7.05 pH.

When value rises to ≥ 7.00 pH, relay closes, until value falls back to ≤ 6.95 pH.

Figure 34 - Alarm Relay Example

***B Setpoint**
***B Hysteresis**
***B Delay**
***B Phasing**

If Relay B Mode is set to **CON** or **FAIL**, then Relay B will function identically to Relay A CON or FAIL modes described earlier. Relay B settings appear in the CONFIG menu list automatically.

***Timer B ON**
***Timer B OFF**
***Timer B HOLD**

If Relay B Mode is set to **CLn1** (see **Relay B Mode**), then these timer settings appear in the CNTRL menu list automatically.

Relay B will toggle ON and OFF based on the time settings entered by the user. The timer ON setting controls the amount of time that Relay B is engaged (N.O. contact closed), and the timer OFF setting controls the amount of time that Relay B is released (N.O. contact open.)

The timer HOLD setting allows an output hold time to be entered into the ON/OFF cleaning cycle. This hold time allows the outputs to stabilize back to normal readings before the outputs are released from their “hold” state. Using this feature properly avoids disturbing any instruments connected to the outputs during the cleaning cycle – where D.O. readings can fluctuate.

Note: The sensor wash timer is not based on a “real-time” clock circuit. Therefore, the time accuracy is only within about 10 minutes per day.

Note: A timer wash cycle can be manually started by pressing and holding the ENTER key for a few seconds while viewing the timer status screen in the MEAS menu. The timer must be in the “OFF” state” to allow a manual start (“T” is not flashing in the display.) After this forced cycle, the system will return to normal.

**C Setpoint
C Hysteresis
C Delay
C Phasing**

If Relay C Mode is set to CON (see Relay C Mode), then Relay C will function identically to Relay A. Relay C settings appear in the CONFIG menu list automatically.

**D,E,F Setpoint
D,E,F Hyster
D,E,F Delay
D,E,F Phasing**

If Relay D, E, or F Mode is set to CON (see Relay D,E,F Modes), then the Relay will function identically to Relay A. Relay settings appear in the CONFIG menu automatically.

5.26 Diagnostics Menu [DIAG]

The diagnostics menu contains all of the user settings that are specific to the system diagnostic functions, as well as functions that aid in troubleshooting application problems.

Set Hold

The Set Hold function locks the current loop output values on the present process value. This function can be used prior to calibration, or when removing the sensor from the process, to hold the output in a known state. Once HOLD is released, the outputs return to their normal state of following the process input. The transfer out of HOLD is bumpless on the both analog outputs - that is, the transfer occurs in a smooth manner rather than as an abrupt change. An icon on the display indicates the HOLD state, and the HOLD state is retained even if power is cycled. Press ENTER to initiate user entry mode, and entire value will flash. Use the UP arrow key to modify the desired value, selections are **ON** for engaging the HOLD function, and **OFF** to disengage the function. Press ENTER to store the new value.

CAUTION: There is no time-out on the hold feature. Once placed into hold mode, return to normal operation must be done manually.

The Set Hold function can also hold at an output value specified by the user. To customize the hold value, first turn the HOLD function on. Press the ESC key to go to the DIAG Menu and scroll to Sim Output using the UP arrow key. Press ENTER. Follow the instructions under Sim Output (see following page).

Fault List

The Fault List screen is a read-only screen that allows the user to display the cause of the highest priority failure. The screen indicates the number of faults present in the system and a message detailing the highest priority fault present. Note that some faults can result in multiple displayed failures due to the high number of internal tests occurring. As faults are corrected, they are immediately cleared.

Faults are not stored and are immediately removed if power is cycled. If the problem causing the faults still exists, however, faults will be displayed again after power is re-applied and a period of time elapses during which the diagnostic system re-detects them. The exception to this rule is the calibration failure. When a calibration fails, no corrupt data is stored. Therefore, the system continues to function normally on the data that was present before the calibration was attempted.

After 30 minutes or if power to the transmitter is cycled, the failure for calibration will be cleared until calibration is attempted again. If the problem still exists, the calibration failure will re-occur. Press ENTER to initiate view of the highest priority failure. The display will automatically return to normal after a few seconds.

PID Timer

This function sets a timer to monitor the amount of time the PID controller remains at 0% or 100%. This function only appears if the PID controller is enabled. If the timer is set to 0000, the feature is effectively disabled. If the timer value is set to any number other zero, a FAIL condition will occur if the PID controller remains at 0% or 100% for the timer value. If one of the relays is set to FAIL mode, this failure condition can be signaled by a changing relay contact.

Press ENTER to initiate user entry mode, and the entire value will flash. Use the UP arrow key to modify desired value; range of value is 0-9999 seconds. Press ENTER to store the new value.

Sim Out

The Sim Out function allows the user to simulate the pH level of the instrument in the user selected display range. The user enters a pH value directly onto the screen, and the output responds as if it were actually receiving the signal from the sensor. This allows the user to check the function of attached monitoring equipment during set-up or troubleshooting. Escaping this screen returns the unit to normal operation. Press ENTER to initiate the user entry mode, and the right-most digit of the value will flash. Use arrow keys to modify desired value.

The starting display value will be the last read value of the input. The output will be under control of the SIM screen until the ESC key is pressed.



NOTE:

If the HOLD function is engaged before the Sim Output function is engaged, the simulated output will remain the same even when the ESC key is pressed. Disengage the HOLD function to return to normal output.

Glass Diags

This function allows the user to shut off the glass breakage/leak diagnostics. It does not affect the state of the remaining system diagnostics. This capability is provided to eliminate nuisance trips in electrically noisy applications, such as some plating operations. If ON, Relay B is automatically configured as a fail alarm relay. The relay trips on any fail condition. Therefore, the normal settings for control Relay B will disappear from the CONFIG menu since they cannot be used. Note that the probe timer function can also alter the operation of Relay B. If the electrode diagnostic function is enabled, that function takes precedence over the probe timer. **Note also that this function cannot be used with conventional pH sensors. It works only when using the Q25 differential pH sensors.**

PID Timer

This function sets a timer to monitor the amount of time the PID controller remains at 0% or 100%. This function only appears if the PID controller is enabled. If the timer is set to 0000, the feature is effectively disabled. If the timer value is set to any number other zero, a FAIL condition will occur if the PID controller remains at 0% or 100% for the timer value. If one of the relays are set to FAIL mode, this failure condition can be signaled by a changing relay contact.

Press ENTER to initiate user entry mode, and the entire value will flash. Use the UP arrow key to modify desired value; range of value is 0-9999 seconds. Press ENTER to store the new value

Fail Out #1

This function enables the user to define a specified value that the main current output will go to under fault conditions. When the Relay Option Board is installed, the display will read **Fail Out #1**. When enabled to **ON**, the output may be forced to the current value set in **Fail Val** (next item.) With the Fail Out setting of ON, and a Fail Val setting of 6.5 mA, any alarm condition will cause the current loop output to drop outside the normal operating range to exactly 6.5 mA, indicating a system failure that requires attention.

Press ENTER to initiate user entry mode, and the entire value will flash. Use the UP arrow key to modify desired value; selections are **ON**, **OFF**. Press ENTER to store the new value.

Fail Val #1

Sets the output failure value for lout#1. When **Fail Out** above is set to **ON**, this function sets value of the current loop under a FAIL condition. When the Relay Option Board is installed, the display will read **Fail Out #1**. The output may be forced to any current value between 4-20 mA.

Press ENTER to initiate user entry mode, and the entire value will flash. Use the UP arrow key to modify desired value; selections are between **4mA**, and **20mA**. Press ENTER to store the new value.

Fail Out #2

This function sets the fail-mode of current loop output #2 under a FAIL condition. The settings and operation are identical to Fail Out for output #1.

Fail Val #2

This function sets the value of current loop output #2 under a FAIL condition. The settings and operation are identical to Fail Out for output #1.

***Fail Out #3**

OPTIONAL. This function sets the fail-mode of current loop output #3 under a FAIL condition. The settings and operation are identical to Fail Out for output #1.

- *Fail Val #3** **OPTIONAL.** This function sets the value of current loop output #3 under a FAIL condition. The settings and operation are identical to Fail Out for output #1.
- *Failsafe** This function allows the user to set the optional system relays to a failsafe condition. In a failsafe condition, the relay logic is reversed so that the relay is electrically energized in a normal operating state. By doing this, the relay will not only change state when, for example, a pH limit is exceeded, but also when power is lost to the controller.
- When failsafe is selected to be ON, the normally-open contacts of the relay will be closed during normal operation. To make this configuration less confusing, the LCD icon logic is reversed with this setting, and the icon is OFF under this normal condition. Therefore, when the trip condition occurs, the closed N.O. contacts will be opened (relay de-energized), and the LCD icon will illuminate. In addition, a power fail would also cause the same contacts to open.
- Start Delay** This function is designed to minimize control or alarm issues arising from temporary power loss. When power goes down, the monitor records the analog output values and the status of relays and PID functions. When power is restored, the analog values and relays will be held at the pre-power loss values for a defined period of time. This “start delay” may be programmed for periods from 0-9.9 minutes. This function is set to 0.0 minutes by default and must be activated by the user if desired by setting a positive time value
- Set Default** The Set Default function allows the user to return the instrument back to factory default data for all user settings or for just the calibration default. It is intended to be used as a last resort troubleshooting procedure. All user settings or the calibration settings are returned to the original factory values. Hidden factory calibration data remains unchanged. Press ENTER to initiate user entry mode and select either All or CAL with the UP arrow key.

Part 6 – Calibration

6.1 Overview and Methods

Since the sensor slope (mV/pH output) will degrade over time, the instrument must be calibrated periodically to maintain a high degree of measurement accuracy. Frequency of calibration must be determined by the application. High temperature applications or applications involving extreme pH operating conditions may require more frequent calibration than those that operate at more neutral pH levels and ambient level temperatures. It is important for the user to establish a periodic cleaning and calibration schedule for sensor maintenance to maintain high system accuracy.

Before calibrating the instrument for the very first time after initial installation, it is important to select the proper operating parameters in the configuration menus for items like Sensor Type and Auto Buffers.

If Auto Buffers is not enabled, select buffers with values that are close to the normal operating pH of the process. For example, if the process is operating normally at 8 pH, buffer values of 9.18 pH and 7.00 pH are preferred over buffers of 4.00 pH and 7.00 pH. If possible, select one of the buffers to be near 7.00 pH.



NOTE: Buffers must be at least 2 pH units apart to ensure accurate calibration.

The system provides two methods of pH calibration: 2-point and 1-point. These two methods are significantly different. See Sections 6.13 and 6.14 for a brief description of their uses.

6.11 Sensor Slope

The sensor slope is a number (expressed as a percentage) which represents the current condition of the sensor electrodes. The slope display is updated after every calibration. When new, the sensor slope should be between 95% and 105%. A 100% slope represents an ideal sensor output of 59.16 mV/pH, from standardization (7.00 pH at 25°C). Over time, the glass electrodes in the sensor will age with use. This results in a reduction of the slope (mV/pH output) of the sensor. Thus a sensor slope of 85% is equivalent to an output of 50.29 mV/pH from standardization. The instrument will not allow calibrations on a sensor with a slope less than 80%. The slope information from the most recent calibration can be viewed at any time in the Measure Menu (see Section 5.22).

6.12 Sensor Offset

Sensor offset is a number that indicates sensor output (expressed in mV) in 7.00 pH buffer at 25 °C. Ideally, the sensor will output 0 mV under these conditions. A sensor offset reading of +10 mV indicates that the sensor will output +10 mV when placed into a perfect 7.00 pH buffer at 25 °C. In other words, sensor offset shifts the entire mV/pH curve up or down. Sensor offset is generally produced by a small voltage drop at the sensor reference junction. Large offsets are most typically the result of foulants on the reference junction, an aged reference junction, or a weak reference fill solution. The instrument does not allow calibrations on a sensor with an offset greater than +90 mV or less than –90 mV. Sensor offset information from the most recent calibration can be viewed at any time in the Measure Menu (See Section 5.22).

6.13 2-Point Calibration Explained

The 2-point calibration method involves the movement of the sensor through two known pH buffer values. Therefore, the sensor must be removed from the application to utilize this method. Two-point calibration adjusts both the slope and the offset of the sensor. It is the recommended method of calibration for highest accuracy. In addition, this calibration method utilizes an automatic buffer recognition and compensation method.



IMPORTANT: the 2-point calibration mode **MUST** be performed when a new sensor is first put into operation so that accurate calibration data is available for possible later 1-point calibrations.

6.14 1-Point Calibration Explained

The 1-point calibration method is generally known as the "grab sample" calibration method. In the 1-point calibration method, the sensor may be removed from the application and placed into one buffer. It may also be left in the measurement process and calibrated by reference. 1-point calibration adjusts only the sensor offset. Since the sensor slope degrades much slower than the sensor offset, this method may be used as a frequent calibration method between more involved 2-point calibrations. For example, a user may choose to perform on-line 1-point calibrations weekly and 2-point calibrations monthly.

6.2 Performing a 2-Point Calibration

The 2-point calibration method utilizes an automatic buffer recognition and compensation system. For this system to operate properly, the user must first configure the proper buffers in the Set Buffers screen (see Section 5.24). If the buffers are not present in this menu, the user can override the automatic values and enter arbitrary values. However, the highest accuracy is provided when the user selects and uses buffers from this pre-defined table list. With the pre-defined buffers, the temperature variations in the buffer are automatically compensated for during the calibration process. If the buffer data is manually entered, the calibration buffer sample must be very temperature stable to achieve the same degree of accuracy.

Procedure

1. Remove sensor from application. Rinse and clean if necessary.
2. Allow sensor to temperature equilibrate with the buffer as best as possible. With the sensor coming from an application solution that differs greatly in temperature from the buffer, the user may have to wait as much as 20 minutes for this to occur.
3. Scroll to the CAL menu section using the MENU key and press ENTER or the UP arrow key. **Cal pH** will then be displayed.
4. Press the ENTER key. The screen will display a flashing 1 for 1-point or a 2 for 2-point calibration. Using the UP arrow key, set for a 2-point calibration and press ENTER.



5. The display will prompt the user to place the sensor in the first buffer and press ENTER. If the sensor has been placed into this buffer already, once the temperature has stabilized, press ENTER to continue.
6. The present pH value will be displayed and the secondary line of the display will flash **Wait** for approximately 10-15 seconds. At this time the system is attempting to recognize the first buffer value from the two values entered into the Set Buffers selection.

7. The screen will display the buffer value to be used for calibration. If the user chooses to change this value, the arrow keys can be used to modify the value. Any value between 0.00 and 14.00 pH can be entered. After adjusting this value, or to accept the automatic value, press ENTER.
8. The system now begins acquiring data for the calibration value of this buffer point. As data is gathered, the units for pH and temperature may begin to flash. Flashing units indicates that this parameter is unstable. The data point acquisition will stop only when the data remains stable for a pre-determined time. This can be overridden by pressing ENTER. If the data remains unstable for 10 minutes, calibration will fail and **Cal Unstable** will be displayed.
9. Once the first calibration value has been established, the screen will prompt the user to move the sensor to the second buffer. At this point, rinse sensor with water and move the sensor into the second buffer solution. Allow temperature to stabilize, and then press ENTER.
10. The present pH value will be displayed and the secondary line of the display will flash **Wait** for approximately 10-15 seconds. At this time the system is attempting to recognize the second buffer value from the two values entered into the Set Buffers selection.
11. The screen will display the buffer value to be used for calibration. If the user chooses to change this value, the arrow keys can be used to modify the value. Any value between 0.00 and 14.00 pH can be entered. The second buffer must be at least 2 pH units away from the first. After adjusting this value, or to accept the automatic value, press ENTER.
12. The system now begins acquiring data for the calibration value of this buffer point. As data is gathered, the units for pH and/or temperature may again flash, indicating unstable parameters.
13. If accepted, the screen will display the message **PASS** with the new slope and offset readings, then it will return to the main measurement display. If the calibration fails, a message indicating the cause of the failure will be displayed and the FAIL icon will be turned on.

The sensor offset value in % from the last span calibration is displayed on the lower line of the Default Menus for information purposes.

6.3 Performing a 1-Point Calibration

The 1-point, or sample calibration method does not utilize the automatic buffer recognition and compensation system. This calibration method is intended to be primarily used as an on-line calibration method, in which the actual calibration point will not be a buffer value. However, the sensor can be removed and calibrated in a separate buffer. During calibration, the system will display the current pH reading and the user can manually enter a reference value from a lab grab-sample or a comparative reference instrument.

Procedure

1. Determine whether the calibration will be done on-line or with the sensor removed and placed into a buffer. If the sensor is removed from the application, rinse and clean if necessary.
2. If the sensor has been removed and placed into a buffer, allow sensor to temperature equilibrate with the buffer as much as possible. With the sensor coming from an application which differs greatly in temperature difference, the user may have to wait as much as 20 minutes. If the sensor is on-line, the user may want to set the output HOLD feature prior to calibration to lock out any output fluctuations.
3. Scroll to the CAL menu section using the MENU key and press ENTER or the UP arrow key. **Cal pH** will then be displayed.
4. Press the ENTER key. The screen will display a flashing 1 for 1-point or a 2 for 2-point calibration. Using the UP arrow key, set for a 1-point calibration and press ENTER.



5. The system now begins acquiring data for the calibration value. As data is gathered, the units for pH and temperature may flash. Flashing units indicate that this parameter is unstable. The calibration data point acquisition will stop only when the data remains stable for a pre-determined amount of time. This can be overridden by pressing ENTER. If the data remains unstable for 10 minutes, the calibration will fail and the message **Cal Unstable** will be displayed.
6. The screen will display the last measured pH value [or the auto buffer value, if activated] and a message will be displayed prompting the user for the lab value. The user must then modify the screen value with the arrow keys and press ENTER. The system then performs the proper checks.
7. If accepted, the screen will display the message **PASS** with the new offset reading, and then it will return to the main measurement display. If the calibration fails, a message indicating the cause of the failure will be displayed and the FAIL icon will be turned on.

6.4 Temperature Calibration

The temperature input is factory calibrated for the highest accuracy. Temperature calibration is not recommended unless the installation involves long cable lengths. For example, at 50 feet, readings may be off $\pm 0.2^{\circ}\text{C}$. The temperature calibration sequence is essentially a 1-point offset calibration that allows adjustments of approximately $\pm 5^{\circ}\text{C}$.

The sensor temperature may be calibrated on line, or the sensor can be removed from the process and placed into a known solution temperature reference. In any case, it is critical that the sensor be allowed to reach temperature equilibrium with the solution in order to provide the highest accuracy. When moving the sensor between widely different temperature conditions, it may be necessary to allow the sensor to stabilize as much as one hour before the calibration sequence is initiated. If the sensor is on-line, the user may want to set the output HOLD feature prior to calibration to lock out any output fluctuations.

Procedure

1. Scroll to the CAL menu section using the MENU key and press ENTER or the UP arrow key.
2. Press the UP arrow key until **Cal Temp** is displayed.
3. Press the ENTER key. The message **Place sensor in solution then press ENTER** will be displayed. Move the sensor into the calibration reference (if it hasn't been moved already) and wait for temperature equilibrium to be achieved. Press ENTER to begin the calibration sequence.
4. The message **Adjust temp value then press ENTER** will be displayed, and the right-most digit will begin to flash, indicating that the value can be modified. Using the UP and LEFT arrow keys, modify the value to the known ref solution temperature. Adjustments up to $\pm 5^{\circ}\text{C}$ from the factory calibrated temperature are allowed. Press ENTER.
5. The calibration data gathering process will begin. The message **Wait** will flash as data is accumulated and analyzed. The $^{\circ}\text{C}$ or $^{\circ}\text{F}$ symbol may flash periodically if the reading is too unstable.
6. Once completed, the display will indicate **PASS** or **FAIL**. If the unit fails, the temperature adjustment may be out of range, the sensor may not have achieved complete temperature equilibrium, or there may be a problem with the temperature element. In the event of calibration failure, it is recommended to attempt the calibration again immediately.

Part 7 – PID Controller Details

7.1 PID Description

PID control, like many other control schemes, are used in chemical control to improve the efficiency of chemical addition or control. By properly tuning the control loop that controls chemical addition, only the amount of chemical that is truly required is added to the system, saving money. The savings can be substantial when compared to a system which may be simply adding chemical at a constant rate to maintain some minimal addition under even the worst case conditions. The PID output controller is highly advantageous over simple control schemes that just utilize direct (proportional only) 4-20 mA output connections for control, since the PID controller can automatically adjust the “rate” of recovery based on the error between the setpoint and the measured value – which can be a substantial efficiency improvement..

The PID controller is basically designed to provide a “servo” action on the 4-20 mA output to control a process. If the user requires that a measured process stay as close as possible to a specific setpoint value, the controller output will change from 0% to 100% in an effort to keep the process at the setpoint. To affect this control, the controller must be used with properly selected control elements (valves, proper chemicals, etc.) that enable the controller to add or subtract chemical rapidly enough. This is not only specific to pumps and valves, but also to line sizes, delays in the system, etc.

This section is included to give a brief description of tuning details for the PID controller, and is not intended to be an exhaustive analysis of the complexities of PID loop tuning. Numerous sources are available for specialized methods of tuning that are appropriate for a specific application.

7.2 PID Algorithm

As most users of PID controllers realize, the terminology for the actual algorithm terms and even the algorithms themselves can vary between different manufacturers. This is important to recognize as early as possible, since just plugging in similar values from one controller into another can result in dramatically different results. There are various basic forms of PID algorithms that are commonly seen, and the implementation here is the most common version; The ISA algorithm (commonly referred to as the “ideal” algorithm.)

$$output = P \left[e(t) + \frac{1}{I} \int e(t) dt + D \frac{de(t)}{dt} \right]$$

Where:

output =	controller output
P =	proportional gain
I =	integral gain
D =	derivative gain
t =	time
e(t) =	controller error (e=measured variable – setpoint)

Figure 35 - Q45H ISA (ideal) PID Equation

The most notable feature of the algorithm is the fact the proportional gain term affects all components directly (unlike some other algorithms - like the “series” form.) If a pre-existing controller utilizes the same form of the algorithm shown above, it is likely similar settings can for made if the units on the settings are exactly the same. Be careful of this, as many times the units are the reciprocals of each other (i.e. reps-per-min, sec-per-rep.)

PID stands for “proportional, integral, derivative.” These terms describe the three elements of the complete controller action, and each contributes a specific reaction in the control process. The PID controller is designed to be primarily used in a “closed-loop” control scheme, where the output of the controller directly affects the input through some control device, such as a pump, valve, etc.

Although the three components of the PID are described in the setting area (section 4.25), here are more general descriptions of what each of the PID elements contribute to the overall action of the controller.

- P** Proportional gain. With no “I” or “D” contribution, the controller output is simply a factor of the proportional gain multiplied by the input error (difference between the measured input and the controller setpoint.) Because a typical chemical control loop cannot react instantaneously to a correction signal, proportional gain is typically not efficient by itself – it must be combined with some integral action to be useful. Set the P term to a number between 2-4 to start. Higher numbers will cause the controller action to be quicker.
- I** Integral gain. Integral gain is what allows the controller to eventually drive the input error to zero – providing accuracy to the control loop. It must be used to affect the accuracy in the servo action of the controller. Like proportional gain, increasing integral gain results in the control action happening quicker. Set the I term to a number between 3-5 to start (1-2 more than P). Like proportional gain, increasing the integral term will cause the controller action to be quicker.

- D Derivative gain. The addition of derivative control can be problematic in many applications, because it greatly contributes to oscillatory behavior. In inherently slow chemical control process', differential control is generally added in very small amounts to suppress erratic actions in the process that are non-continuous, such as pumps and valves clicking on and off. However, as a starting point for chemical process control, its best to leave the "D" term set to 0.

Based on these descriptions, the focus on tuning for chemical applications really only involves adjustment of "P" and "I" in most cases. However, increasing both increases the response of the controller. The difference is in the time of recovery. Although combinations of high "P's" and low "I" will appear to operate the same as combinations of low "P's" and high "I's", there will be a difference in rate of recovery and stability. Because of the way the algorithm is structured, large "P's" can have a larger impact to instability, because the proportional gain term impacts all the other terms directly. Therefore, keep proportional gain lower to start and increase integral gain to achieve the effect required.

Many of the classical tuning techniques have the user start with all values at 0, and then increase the P term until oscillations occur. The P value is then reduced to $\frac{1}{2}$ of the oscillatory value, and the I term is increased to give the desired response. This can be done with the Q45H controller, with the exception that the I term should start no lower than 1.0.

If it appears that even large amounts of integral gain (>20) don't appreciably increase the desired response, drop I back to about 1.0, and increase P by 1.00, and start increasing I again. In most chemical control schemes, I will be approximately 3 times the value of P.

7.3 Classical PID Tuning

Unlike many high speed position applications where PID loops are commonly used, the chemical feed application employed by this instrument does not require intense mathematical exercise to determine tuning parameters for the PID. In fact, the risk of instability is far greater with overly tuned PID control schemes. In addition, many of the classical mathematical exercises can be damaging or wasteful in the use of chemicals when the process is bumped with large amounts of input error to seek a response curve. Because of this, the general adjustment guidelines described in section 6.2 are sufficient for almost all application tuning for this instrument. Beyond this, many sources are available for classical tuning methods.

7.4 Manual PID Override Control

The Q45 PID output function allows the user to take manual control of the PID control signal. This is often useful when starting up a control loop, or in the event that you wish to bump the system manually to measure system response time.

To access the manual PID control, you must be in the MEASURE mode of operation and you must have the PID output displayed on the lower line. This line will indicate “XX.X% XX.X mA” with the X values simply indicating the current values. With this display on the screen, press and hold the ENTER key for about 5 seconds. You will see a small “m” show up between the % value and the mA value. This indicates you are now in manual mode.

Once in manual, you may increase the PID output by pressing the UP arrow or you may decrease the output by pressing the LEFT arrow. This will allow you to drive the PID output to any desired setting.

To revert to normal PID control, press and hold the ENTER key again until the “m” indicator disappears.

7.5 Common PID Pitfalls

The most common problem occurring in PID control applications involves the false belief that proper settings on only the PID controller can balance any process to an efficient level.

Close-loop control can only be effective if all elements in the loop are properly selected for the application, and the process behavior is properly understood. Luckily, the nature of simple chemical control process' are generally slow in nature. Therefore, even a de-tuned controller (one that responds somewhat slowly) can still provide substantial improvements to setpoint control. In fact, damaging oscillatory behavior is far more likely in tightly tuned controllers where the user attempted to increase response too much.

When deciding on a PID control scheme, it is important to initially review all elements of the process. Sticking valves, undersized pumps, or delays in reaction times associated with chemical addition can have a dramatic effect on the stability of the control loop. When controlling a chemical mix or reaction, the sensor should be placed in a location that ensures proper mixing or reaction time has occurred.

The easiest processes to control with closed-loop schemes are generally linear, and symmetrical, in nature. For example, controlling level in tank where the opening of valve for a fixed period of time corresponds linearly to the amount that flows into a tank. Chemical control process' can be more problematic when the nature of the setpoint value is non-linear relative to the input of chemical added. For example, pH control of a process may appear linear only in a certain range of operation, and become highly exponential at the extreme ranges of the measuring scale. In addition, if a chemical process is not symmetrical, that means it responds differentially to the addition and subtraction of chemical. It is important in these applications to study steady-state impact as well as step-change impact to process changes. In other words, once the process has apparently been tuned under normal operating conditions, the user should attempt to force a dramatic change to the input to study how the output reacts. If this is difficult to do with the actual process input (the recommended method), the user can place the control in manual at an extreme control point such as 5% or 95%, and release it in manual. The recovery should not be overly oscillatory. If so, the loop needs to be de-tuned to deal with that condition (reduce P and/or I.)

Part 8 – Maintenance and Troubleshooting

8.1 System Checks

1. If the FAIL icon is flashing on the display, check the Fault List to determine the cause of the failure. To access the Fault List, press the MENU/ESC key until the DIAG menu appears. Then press the UP arrow key until the Fault List appears. Press the ENTER key to access the Fault List, and the highest priority fault message will be displayed. For a list of all messages and possible causes/solutions, see message table at the end of this section.
2. In **ALL** environments, connect an earth ground jumper to earth terminal connection on monitor.
3. Perform a two-point calibration with two fresh buffers prior to sensor installation.
4. Check sensor cable color to terminal strip markings.
5. For highly unstable behavior, remove sensor from the process and measure the process solution in a plastic beaker. If the reading now stabilizes, place wire in beaker solution and actual process solution to determine if a ground loop exists.
6. Verify that the black rubber shipping boot has been removed from the end of the sensor prior to submersion. If the sensor has been left to dry out, allow sensor to be submerged in buffer or water to re-hydrate for at least 4 hours. The saltbridge may need replacement if the sensor has dried out for too long.
7. If the instrument 4-20 mA output is connected into other control systems, disconnect output loop from system load and run through a handheld DMM to monitor current. Verify that the system operates correctly in this mode first.

8.2 Instrument Checks

1. Remove sensor completely and connect 1100 Ohms from the yellow to black sensor input leads. Make sure the unit is configured for a Pt1000 thermal element and that the temperature is not in manual locked mode. Also, connect a wire jumper from the red cable lead input to the green cable lead input. The temperature reading should be approximately 25°C, the pH reading should be approximately 7.00 pH, and the sensor mV reading should be between -20 and +20 mV.

2. With a DMM, measure the DC voltage from the white sensor lead connection to the black sensor lead connection. With the positive DMM lead on the white wire, the meter should read between -4.5 and -5.5 VDC.
3. With power disconnected, unplug the fuse from the power supply board and verify continuity across the fuse.

8.3 Display Messages

The Q45 Series instruments provide a number of diagnostic messages that indicate problems during normal operation and calibration. These messages appear as prompts on the secondary line of the display or as items on the Fault List as follows.

The following messages will appear as prompts:

MESSAGE	DESCRIPTION	POSSIBLE CORRECTION
Max is 200	Entry failed, maximum value allowed is 200.	Reduce value to ≤ 200
Min is 200	Entry failed, minimum value allowed is 200.	Increase value to ≥ 200
Cal Unstable	Calibration problem, data too unstable to calibrate.	Clean sensor, get fresh cal solutions, allow temperature and pH readings to fully stabilize, do not handle sensor or cable during calibration.
Slope HIGH	Sensor slope from calibration is greater than 110%.	Get fresh cal solutions, allow temperature and pH readings to fully stabilize, check for correct buffer values
Slope LOW	Sensor slope from calibration is less than 80%.	Clean sensor, get fresh cal solutions, allow temperature and pH readings to fully stabilize, check for correct buffer values.
Offset HIGH	Sensor offset from calibration is less than -90 mV or greater than $+90$ mV	Clean or replace saltbridge, replace reference cell solution, clean sensor, get fresh cal solutions, allow temperature and pH readings to fully stabilize, check for correct buffer values.
Out of Range	Input value is outside selected range of the specific list item being configured.	Check manual for limits of the function to be configured.
Locked!	Transmitter security setting is locked.	Enter security code to allow modifications to settings.
Unlocked!	Transmitter security has just been unlocked.	Displayed just after security code has been entered.
TC-F25 lock!	The TC selection is in F25 mode, locked at 25 °C	Calibration and TC adjustment cannot be performed while the TC is in F25 mode. To allow access to TC calibrations, change TC mode from F25 (fixed 25) to SENS (sensor).

The following messages will appear as items on the Fault List:

MESSAGE	DESCRIPTION	POSSIBLE CORRECTION
Sensor High	The raw signal from the sensor is too high.	Check wiring connections to sensor.
Sensor Low	The raw signal from the sensor is too low.	Check wiring connections to sensor.
pH too High	The pH reading is > 14.00 pH.	The pH reading is over operating limits.
pH too Low	The pH reading is < 0.00 pH.	The pH reading is under operating limits.
Temp High	The temperature reading is > 110 °C.	The temperature reading is over operating limits. Check wiring and expected temp level. Perform RTD test as described in sensor manual. Recalibrate sensor temperature element if necessary.
Temp Low	The temperature reading is < -10 °C	The temperature reading is under operating limits. Check wiring and expected temp level. Perform RTD test as described in sensor manual. Recalibrate sensor temperature element if necessary.
TC Error	TC may be open or shorted.	Check sensor wiring and perform RTD test as described in sensor manual.
Meas Break	Leakage detected on measuring electrode of sensor.	Measuring electrode glass may be cracked or broken. Electrical noise may falsely trip this diagnostic. Turn off glass diagnostic feature and see if sensor operates correctly. If it does not, sensor must be replaced.
Ref Break	Leakage detected on reference electrode of sensor.	Reference glass electrode may be cracked or broken. Electrical noise may falsely trip this diagnostic. Turn off glass diagnostic feature and see if sensor operates correctly. If it does not, sensor must be replaced.

MESSAGE	DESCRIPTION	POSSIBLE CORRECTION
pH Cal Fail	Failure of pH calibration.	Clean sensor, get fresh cal solutions, regenerate sensor (if necessary) and redo calibration. If still failure, sensor slope may be less than 80% or offset may be out of range. Perform sensor tests as described in sensor manual. Replace sensor if still failure.
TC Cal Fail	Failure of temperature calibration.	Clean sensor, check cal solution temperature and repeat sensor temp calibration. TC calibration function only allows adjustments of +/- 6 °C. If still failure, perform sensor tests as described in sensor manual. Replace sensor if still failure. Note that TC offset may also be adjusted using the Cal TC Factor function (See Section 6.5) which involves no calibration reference solutions.
Eeprom Fail	Internal nonvolatile memory failure	System failure, consult factory.
Chcksum Fail	Internal software storage error.	System failure, consult factory.
Display Fail	Internal display driver fail.	System failure, consult factory.
mV Cal Fail	Failure of factory temperature calibration.	Consult factory.

8.4 Cleaning the Sensor

Keep the sensor as clean as possible for optimum measurement accuracy - this includes both the saltbridge and the measuring electrode glass. Frequency of cleaning depends upon the process solution.

Carefully wipe the measuring end of the sensor with a clean soft cloth. Then rinse with clean, warm water - use distilled or de-ionized water if possible. This should remove most contaminate buildup.

Prepare a mild solution of soap and warm water. Use a non-abrasive detergent (such as dishwashing liquid).



NOTE: DO NOT use a soap containing any oils (such as lanolin). Oils can coat the glass electrode and harm sensor performance.

Soak the sensor for several minutes in the soap solution.

Use a small, extra-soft bristle brush (such as a mushroom brush) to thoroughly clean the electrode and saltbridge surfaces. If surface deposits are not completely removed after performing this step, use a dilute acid to dissolve the deposits. After soaking, rinse the sensor thoroughly with clean, warm water. Placing the sensor in pH 7 buffer for about 10 minutes will help to neutralize any remaining acid.



NOTE: DO NOT soak the sensor in dilute acid solution for more than 5 minutes. This will help to prevent the acid from being absorbed into the saltbridge.



WARNING: ACIDS ARE HAZARDOUS. Always wear eye and skin protection when handling. Follow all Material Safety Data Sheet recommendations. A hazardous chemical reaction can be created when certain acids come in contact with process chemicals. Make this determination before cleaning with any acid, regardless of concentration.

8.5 Replacing the Saltbridge and Reference Buffer Solution

1. Hold the sensor with the process electrode pointing up. Place a cloth or towel around the saltbridge. Turn the saltbridge counterclockwise (by hand) to loosen and remove the saltbridge. Do NOT use pliers.
2. Pour out the old reference buffer by inverting the sensor (process electrode pointing down). If the reference buffer does not run out, gently shake or tap the sensor.
3. Rinse the reference chamber of the sensor with de-ionized water. Fill the reference chamber of the sensor with fresh Reference Cell Buffer. The chamber holds 6 to 7 mL of solution. MAKE SURE that 6 to 7 mL is used when refilling. The chamber should be FULL.
4. Inspect the new saltbridge to verify that there are 2 o-rings inside the threaded section of the saltbridge
5. Place the new saltbridge over the ground assembly of the sensor. Place a cloth or towel around the saltbridge and hand-tighten the saltbridge by turning it clockwise.



NOTE: Every ATI Q25P Sensor includes a spare bottle of Reference Buffer Solution, 7.0 pH. This is NOT typical pH 7 buffer, it is a special “high-capacity” buffer developed to ensure the highest possible stability of the reference portion of the pH measurement. No substitutions should be made.

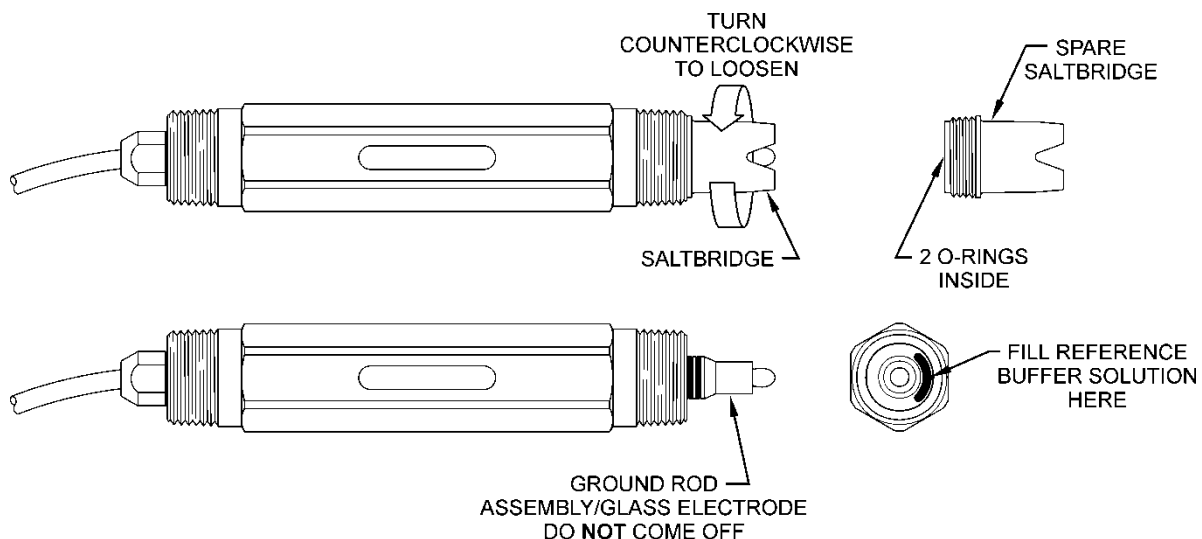

Figure 36 - Replacing the Saltbridge and Reference Buffer

8.6 Troubleshooting

The first step in resolving any measurement problem is to determine whether the trouble lies in the sensor or the transmitter. Since measurement problems can often be traced to dirty sensor electrode glass and/or saltbridge, cleaning the sensor using the method outlined in Section 8.4 should always be the first step in any troubleshooting.

If the sensor cannot be calibrated after cleaning, replace the saltbridge and reference cell buffer 7 pH as outlined in Section 8.5.

If the sensor still cannot be calibrated, perform the following test. A multimeter, 7 pH buffer and another buffer at least 2 pH units away will be needed.

1. With transmitter power on and sensor connected, place the multimeter's positive (+) lead on the white position of the transmitter terminal strip and the negative (-) lead on the black position. The multimeter should read between -4.2 and -6.5 VDC.
2. Disconnect the sensor's red, green, yellow, and white wires from the transmitter or junction box. Re-check Step 1.
3. Place the sensor in pH 7 buffer. As in calibration, allow the temperatures of the sensor and buffer to equilibrate at room temperature (approximately 25 °C).
4. Verify that the sensor's temperature element (Pt1000 RTD) is functioning properly by measuring the resistance between the sensor's yellow and black wires. The nominal resistance value at 25 °C is 1097 ohms. Use the following table as a guide to the approximate resistance value:

°C	RTD Ω
20	1078
25	1097
30	1117
35	1136

5. Reconnect the yellow and white wires.

6. Connect the multimeter's positive (+) lead to the red wire and its negative (-) lead to the green wire. With the sensor in the pH 7 buffer at approximately 20-30 °C, measure the DC millivolts. The sensor offset reading should be between -50 and +50 mV. If it is not, replace sensor reference solution and saltbridge (See Section 8.5) and re-test.
7. With the multimeter connected as in Step 5, rinse the sensor with clean water and place it in the second buffer. Allow the temperatures to equilibrate as before. Now measure the sensor span reading. Use the following table to determine approximate mV:

pH	mV
2.00	+296
4.00	+178
7.00	0
9.18	-129
10.00	-178



NOTE: The mV values listed above are for ideal conditions (sensor offset = 0 mV) and therefore represent midpoints in a range. The table shows the difference in mV which should be seen when going from one pH value to another. For example, at 7.00 pH, the mV reading will be from -50 to +50 mV (at room temperature) if the sensor is working properly. If the reading is exactly +20 mV, then going to 4.00 pH buffer should produce a reading of +198 mV, or a difference of +178 mV.

Spare Parts

<u>Part No.</u>	<u>Description</u>
07-0338	Q46P pH Monitor, 100-240 VAC
07-0339	Q46P pH monitor, 12-24 VDC
07-0340	Q46P pH monitor with Profibus, 100-240 VAC
07-0341	Q46P pH monitor with Profibus, 12-24 VDC
03-0397	Q46P Front Lid Assembly
03-0407	Q46 P/S Assy, 90-260VAC
03-0408	Q46 P/S Assy, 90-260VAC with 3 rd 4-20mA output
03-0409	Q46 P/S Assy, 90-260VAC with 3 relay exp. board
03-0410	Q46 P/S Assy, 12-24 VDC
03-0411	Q46 P/S Assy, 12-24 VDC with 3 rd 4-20mA output
03-0412	Q46 P/S Assy, 12-24 VDC with 3 relay exp. Board
38-0072	Terminal block plug, 3 position (relays)
38-0073	Terminal block plug, 4 position (outputs)
38-0074	Terminal block plug, 3 position (ground)
38-0081	Terminal block plug, 3 position (power)
38-0084	Terminal block plug, 3 position (power) – VDC version*
*NOTE: prior to Dec 2018, VDC (power) Terminal block used the (38-0081)	
23-0029	Fuse, 630mA, 250V, TR-5 (for AC and DC Analyzers)
07-0100	Junction box
31-0057	Sensor interconnect cable
63-0017	¾" NPT Flow "T" adapter for (63-0013)
63-0021	1" NPT Flow "T" adapter for (63-0013)
05-0068	Panel Mount Bracket Kit
07-0209	1" Flow Tee for Q25 Sensors
00-0628	Submersion Mounting Hardware
00-1527	Sealed Twist-Lock Flowcell, for 63-0013 sensors
07-0203	Insertion Assembly without Assist, 1¼"NPT, 316SS
07-0228	Insertion Assembly with Assist, 1¼"NPT, 316SS
07-0224	Insertion Assembly without Ball Valve, 1¼"NPT, 316SS
07-0223	Insertion Assembly without Assist, 1¼"NPT, CPVC
07-0221	1½" NPT Union/Tee Mount, CPVC (uses existing 1½" tee)
44-0219	1½" NPT Tee, Schedule 80, CPVC
07-0210	2" NPT Union/Tee Mount, CPVC (uses existing 2" tee)
44-0233	2" NPT Tee, Schedule 80, CPVC

Q25 pH Sensors & Sensor Parts

07-0050	Q25P1-1-1 pH Sensor, 15 ft. cable
07-0051	Q25P2-1-1 pH Sensor, 15 ft. cable
07-0062	Q25P1-1-2 pH Sensor, 30 ft. cable
07-0063	Q25P2-1-2 pH Sensor, 30 ft. cable
07-0052	Q25P3 Antimony pH Sensor, 15 ft. cable
07-0077	Q25P1-3-1 SS pH Sensor, 15 ft. cable
07-0088	Q25P2-6 pH Sensor with connector
07-0057	Q25P1-2-9 SS Insertion Sensor, specify cable length
07-0117	Q25P2-2-9 SS Insertion Sensor, specify cable length
07-0092	Q25P2-6Ag pH Sensor, Ag/AgCl Ref., with connector
07-0149	Q25P2-1-2Ag pH Sensor, 30 ft. cable, AgCl Ref.
05-0060	Saltbridge replacement for P1 Sensors
05-0066	Saltbridge replacement for P2 Sensors
09-0033	Differential pH/ORP Reference Cell Buffer
09-0052	Convention pH Reference Solution- AgCl Ref.
09-0034	pH 4 Buffer, 1000 mL
09-0036	pH 7 Buffer, 1000 mL
09-0037	pH 10 Buffer, 1000 mL

Conventional Sensors & Sensor Parts

63-0009	Submersible pH Sensor, 25', Pt100
63-0013	Twist-Lock sensor, 25', Pt100
63-0053	Lock-n-Load pH Sensor, 25'
63-0051	Lock-n-Load Temperature Compensator, 25'
63-0058	High Purity Water pH Sensor, 10 ft. cable

Lock/Unlock Code: 1464