

Model Q45/83

Potassium Permanganate (KMnO₄) Monitor

Home Office

Analytical Technology, Inc.
6 Iron Bridge Drive
Collegeville, PA 19426

Ph: (800) 959-0299
(610) 917-0991
Fax: (610) 917-0992
Email: sales@analyticaltechnology.com

European Office

ATI (UK) Limited
Unit 1 & 2 Gatehead Business Park
Delph New Road, Delph
Saddleworth OL3 5DE
Ph: 0800-018-4020
+ 44 (0) 1457-873-318
Fax: + 44 (0) 1457-874-468
Email: sales@atiuk.com

PRODUCT WARRANTY

Analytical Technology, Inc. (Manufacturer) warrants to the Customer that if any part(s) of the Manufacturer's products proves to be defective in materials or workmanship within the earlier of 18 months of the date of shipment or 12 months of the date of start-up, such defective parts will be repaired or replaced free of charge. Inspection and repairs to products thought to be defective within the warranty period will be completed at the Manufacturer's facilities in Collegeville, PA. Products on which warranty repairs are required shall be shipped freight prepaid to the Manufacturer. The product(s) will be returned freight prepaid and allowed if it is determined by the manufacturer that the part(s) failed due to defective materials or workmanship.

This warranty does not cover consumable items, batteries, or wear items subject to periodic replacement including lamps and fuses.

Gas sensors, except oxygen sensors, are covered by this warranty, but are subject to inspection for evidence of extended exposure to excessive gas concentrations. Should inspection indicate that sensors have been expended rather than failed prematurely, the warranty shall not apply.

The Manufacturer assumes no liability for consequential damages of any kind, and the buyer by acceptance of this equipment will assume all liability for the consequences of its use or misuse by the Customer, his employees, or others. A defect within the meaning of this warranty is any part of any piece of a Manufacturer's product which shall, when such part is capable of being renewed, repaired, or replaced, operate to condemn such piece of equipment.

This warranty is in lieu of all other warranties (including without limiting the generality of the foregoing warranties of merchantability and fitness for a particular purpose), guarantees, obligations or liabilities expressed or implied by the Manufacturer or its representatives and by statute or rule of law.

This warranty is void if the Manufacturer's product(s) has been subject to misuse or abuse, or has not been operated or stored in accordance with instructions, or if the serial number has been removed.

Analytical Technology, Inc. makes no other warranty expressed or implied except as stated above.

Table of Contents

PART 1 - INTRODUCTION	5	5.23 Calibration Menu [CAL].....	36
1.1 General.....	5	5.24 Configuration Menu [CONFIG]	37
1.2 Standard System	7	5.25 Control Menu [CONTROL]	39
1.3 Features.....	7	5.26 Diagnostics Menu [DIAG].....	44
1.4 Q45/83 System Specifications	9	PART 6 – CALIBRATION	48
1.5 Q45H Performance Specifications.....	10	6.1 Chemistry System Startup.....	48
PART 2 – MECHANICAL INSTALLATION	11	6.2 Permanganate Calibration.....	49
2.1 Electronic Monitor.....	11	6.11 Permanganate Zero Cal.....	49
2.2 Wall or Pipe Mount Bracket	12	6.12 Permanganate Span Cal	50
2.3 Panel Mount.....	14	6.2 Temperature Calibration	53
2.4 Chemistry Module	15	PART 7 – PID CONTROLLER.....	54
2.5 Sample Inlet Overflow.....	16	7.1 PID Description	54
2.6 Reagent Bottle Brackets.....	17	7.2 PID Algorithm	54
2.7 Reagent Pickup Assembly	18	7.3 Classical PID Tuning	56
PART 3 – ELECTRICAL INSTALLATION	20	7.4 Manual PID Override Control.....	57
3.1 General.....	20	7.5 Common PID Pitfalls.....	57
3.2 Monitor Power Connection.....	20	PART 8 – SYSTEM MAINTENANCE	59
3.3 Chemistry Module Power Connection.....	24	8.1 General.....	59
PART 4 – CHEMISTRY SYSTEM.....	25	8.2 Analyzer Maintenance	59
4.1 Chemistry Module	25	8.3 Sensor Maintenance	59
4.2 Chemistry System Function.....	26	8.31 Sensor Acid Cleaning	60
4.3 Sensor Preparation	26	8.4 Stripping Chamber Maintenance	61
4.4 Sensor Installation.....	28	8.5 Peristaltic Pump Service	62
4.5 Reagent Preparation.....	28	PART 9 – TROUBLESHOOTING.....	63
PART 5 – CONFIGURATION	29	9.1 General.....	63
5.1 User Interface.....	29	9.2 External Sources of Problems.....	63
5.11 Keys.....	30	9.3 Analyzer Tests	64
5.12 Display.....	30	9.4 Chemistry System Tests.....	65
5.2 Software.....	32	9.5 Display Messages	66
5.21 Software Navigation	32	9.6 Sensor Tests	68
5.22 Measure Menu [MEASURE].....	35	SPARE PARTS.....	70

Table of Figures

<i>FIGURE 1 - Q45/83 PERMANGANATE CHEMISTRY SYSTEM</i>	6
<i>FIGURE 2 - Q45 ENCLOSURE DIMENSIONS</i>	11
<i>FIGURE 3 - WALL OR PIPE MOUNT BRACKET</i>	12
<i>FIGURE 4 - WALL MOUNTING DIAGRAM</i>	13
<i>FIGURE 5 - PIPE MOUNTING DIAGRAM</i>	13
<i>FIGURE 6 - PANEL MOUNT (CUTOUT)</i>	14
<i>FIGURE 7 - CHEMISTRY MODULE DIMENSIONS</i>	15
<i>FIGURE 8 - SAMPLE INLET OVERFLOW LOCATION</i>	16
<i>FIGURE 9 - REAGENT BOTTLE BRACKETS</i>	17
<i>FIGURE 10 - REAGENT PICKUP ASSEMBLY</i>	18
<i>FIGURE 11 - COMPLETE REAGENT FEED ASSEMBLY</i>	19
<i>FIGURE 12 - LINE POWER CONNECTION</i>	22
<i>FIGURE 13 - RELAY CONTACTS</i>	23
<i>FIGURE 14 - CHEMISTRY MODULE ELECTRICAL CONNECTIONS</i>	24
<i>FIGURE 15 - CHEMISTRY MODULE COMPONENTS</i>	25
<i>FIGURE 16 - SENSOR ASSEMBLY</i>	27
<i>FIGURE 17 - USER INTERFACE</i>	29
<i>FIGURE 18 - SOFTWARE MAP</i>	34
<i>FIGURE 19 - CONTROL RELAY EXAMPLE, HYSTERESIS & TWO PHASE OPTIONS</i>	43
<i>FIGURE 20 - ALARM RELAY EXAMPLE</i>	44
<i>FIGURE 21 - Q45 ISA PID EQUATION</i>	55
<i>FIGURE 22 - PUMPHEAD ASSEMBLY EXPLODED VIEW</i>	62
<i>FIGURE 23 - Q45 DISPLAY MESSAGES</i>	66
<i>FIGURE 24 - PT100 RTD TABLE</i>	69

Part 1 - Introduction

1.1 General

The Model Q45/83 is an on-line monitoring system designed for the continuous measurement of potassium permanganate in water. The full scale operating range of the system may be selected by the user for 0-2.000 PPM or 0-20.00 PPM, and the sensing system will operate on water streams with temperatures from 0 to 40°C. The Monitor is designed for use on any water sample containing potassium permanganate. **KMnO₄ monitors cannot be used on samples that also contain residual chlorine, dissolved ozone, or chlorine dioxide.** The other limitation is that solids content of the sample be low enough as to not plug the chemistry system.

Potassium permanganate measurement is made using an iodometric method in which KMnO₄ is reacted with potassium iodide (KI), resulting in an equivalent I₂ concentration. The iodine released in this reaction is then stripped from solution and measured using an iodine gas sensor. A chemistry module containing sample and reagent pumps, an air stripping chamber, and iodine gas sensor allow this measurement to occur continuously, with a response time of 90% in approximately 4 minutes.

The measured permanganate concentration is displayed on a backlit liquid crystal display on the front of the electronic unit. Depending on the full scale operating range selected, the unit will display permanganate with a resolution of either 0.01 PPM (10 PPB) or 0.001 (1 PPB). Two 4-20 mA outputs are provided for control, recording or data logging. The output can be programmed for a variety of ranges as is described later in this manual. Alarm contacts are also standard in the electronic package and may be used either for simple control schemes or for signaling operators of abnormal operating conditions.

Figure 1 on the following page shows a typical installation of this monitoring system. For convenience in installation, a special stainless steel mounting panel is available. This panel provides mounting locations for the monitor, chemistry module, and overflow chamber. In addition, it contains a shelf at the bottom for locating the reagent containers used in normal operation.

While the monitor is suitable for outdoor mounting, the chemistry module should have additional protection if mounted outdoors. It is best to mount the chemistry module and reagents inside a general purpose enclosure to keep wind driven rain off of the pumps located on the bottom of the chemistry module. **Do not put the chemistry module in a sealed enclosure.** Sample leakage from the overflow chamber must have a place to drain in case of an overflow or sample line break.

Two separate reagents are required for operation. Reagent filter assemblies are included for each, and must be used to insure that no obstructions occur in the reagent tubing. Three feet of pickup tubing is supplied for each reagent.

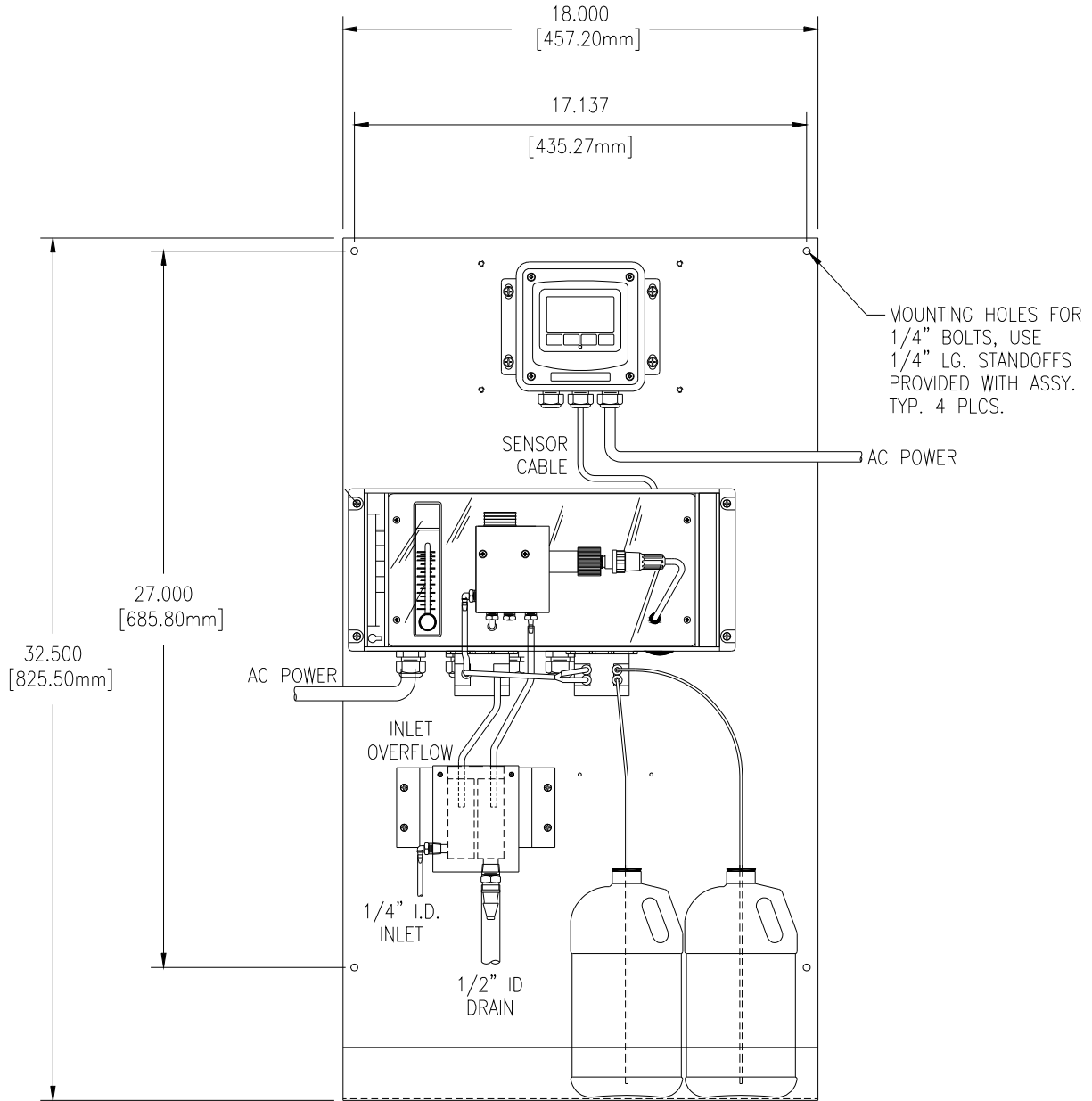

Figure 1 - Q45/83 Permanganate Chemistry System

1.2 Standard System

The standard model Q45-83 system includes three main components, the Q45 analyzer, the Chemistry Module and the Sample Inlet Overflow assembly. These components may be wall mounted in a convenient location, or may be assembled on the optional 00-1261 stainless steel mounting plate. The drawing in Figure 1 provides mounting hole dimensions for the optional stainless steel mounting panel.

A 20' sensor interconnect cable is supplied for connection of the chemistry module to the electronic unit, and the cable length can be increased to 100' maximum using a junction box and additional sensor cable. . All required spare parts are also provided with the basic system, including spare membranes, electrolyte, o-rings, pump tubing, and any special hardware.

1.3 Features

- Standard Q45H electronic monitors are 115 or 230 VAC powered.
- High accuracy, high sensitivity system, measures from 0.001 ppm to 20.00 ppm. Display ranges of 2.000 ppm or 20.00 ppm are selectable.
- Output Hold, Output Simulate, Output Alarm, and Output Delay Functions. All forced changes in output condition include bumpless transfer to provide gradual return to on-line signal levels and to avoid system control shocks on both analog outputs.
- Dual SPDT relay operation and one additional isolated analog output. Software settings for relay control include setpoint, deadband, phase, delay, and failsafe. Software controls automatically appear in menu list when hardware option card is plugged in and system power is applied.
- Selectable PID controller on main analog output. PID includes manual operation feature, and diagnostic "stuck-controller" timer feature for relay notification of control problems.
- Two analog outputs may be configured to track residual permanganate and temperature or both can be assigned to permanganate. Both analog outputs can be individually programmed to fail to specific values.
- Selectable Output Fail Alarm feature on Relay B allows system diagnostic failures to be sent to external monitoring systems.

- Large, high contrast, custom LCD display with LED back light provides excellent readability in any light conditions. The secondary line of display utilizes 5x7 dot matrix characters for clear message display.
- Diagnostic messages provide a clear description of any problem with no confusing error codes to look up. Messages are also included for diagnosing calibration problems.
- Quick and easy one-point calibration method and sensor zero-cal. To provide high accuracy, all calibration methods include stability monitors that check temperature and main parameter stability before accepting data.
- High accuracy three-wire Pt100 temperature input. Temperature element can be user calibrated.
- Security lock feature to prevent unauthorized tampering with transmitter settings. All settings can be viewed while locked, but they cannot be changed.

1.4 Q45/83 System Specifications

Displayed Parameters	Main input, 0.001 ppm to 20.00 ppm Sensor temperature, -10.0 to 55.0 °C (23 to 131 °F) Sensor Current, 0.0–999.9 nA, 0.000 to 99.99 uA Sensor slope/offset Model number and software version PID Controller Status
Main Parameter Ranges	Manual selection of one of the following ranges, 0.000 to 2.000 ppm 0.00 to 20.00 ppm NOTE: Other range selections exist in the electronics are not be used for KMnO₄ measurement.
Display	0.75" (19.1 mm) high 4-digit main display with sign 12-digit secondary display, 0.3" (7.6 mm) 5x7 dot matrix. Integral LED back-light for visibility in the dark.
Keypad	4-key membrane type with tactile feedback, polycarbonate with UV coating
Weight	15.0 lb. (6.82 kg)
Ambient Temperature	Analyzer Service, -20 to 60 °C (-4 to 140 °F) Chemistry Module Service, 2 to 45°C (38 to 131 °F) Storage, -5 to 70 °C (-22 to 158 °F)
Ambient Humidity	0 to 95%, indoor/outdoor use, non-condensing to rated ambient temperature range
Electrical Certification	Ordinary Location, cCSAus (CSA and UL standards - both CSA approved), pollution degree 2, installation category 2
EMI/RFI Influence	Designed to EN 61326-1
Output Isolation	600 V galvanic isolation
Filter	Adjustable 0-9.9 minutes additional damping to 90% step input
Temperature Input	Pt1000 RTD with automatic compensation
Sensor	Polarographic membraned sensor for direct measurement of iodine.

Sensor Interconnect Cable	25 ft. (7.5 meter) cable with 6-pin plug.
Max. Sensor-to-Analyzer Distance	100 feet (30.5 meters)
Power	115 or 230 VAC \pm 10%, 50/60 Hz, 10 VA max
Enclosure	NEMA 4X, polycarbonate, stainless steel hardware, weatherproof and corrosion resistant, HWD: 4.9" (124 mm) x 4.9" (124 mm) x 5.5" (139 mm)
Mounting Options	Wall or pipe mount bracket standard. Bracket suitable for either 1.5" or 2" I.D. U-Bolts for pipe mounting. Panel mount adapter optional.
Conduit Openings	Three 1/2" FNPT openings. Gland seals plus two 1/2" conduit adapters supplied but not installed.
Relays, Electromechanical:	Two SPDT, 6 amp @ 250 VAC, 5 amp @ 24 VDC contacts. Software selection for setpoint, phase, delay, deadband, hi-lo alarm, and failsafe. A-B indicators on main LCD.
Analog Outputs	Two 4-20 mA outputs. Output one programmable for PPM permanganate or PID. Output 2 programmable for PPM permanganate or Temperature. Max load 500 Ohms for each output. Outputs ground isolated and isolated from each other.

1.5 Q45H Performance Specifications

Accuracy	1% of selected range or 0.1 PPM
Repeatability	0.5% of selected range or 0.05 PPM
Sensitivity	0.01 PPM
Non-linearity	0.1% of selected range
Warm-up Time	3 seconds to rated performance (electronics only)
Supply Voltage Effects	\pm 0.05% span
Instrument Response Time	60 seconds to 90% of step input at lowest damping

Part 2 – Mechanical Installation

2.1 Electronic Monitor

The Q45/83 Potassium Permanganate Monitor includes three parts, an electronic display unit, a chemistry module, and a sample inlet overflow assembly. In addition, systems supplied without the stainless steel mounting plate will be supplied with reagent bottle mounting brackets that need to be located below the chemistry module. The monitor should normally be mounted close to the chemistry unit. A cable for interconnection of the chemistry module to the monitor is supplied. The connection is already made in the chemistry unit and the monitor connection color code is shown on a label above the connection terminal blocks. The 4-20 mA outputs and relay outputs are available in the Q45 electronic monitor.

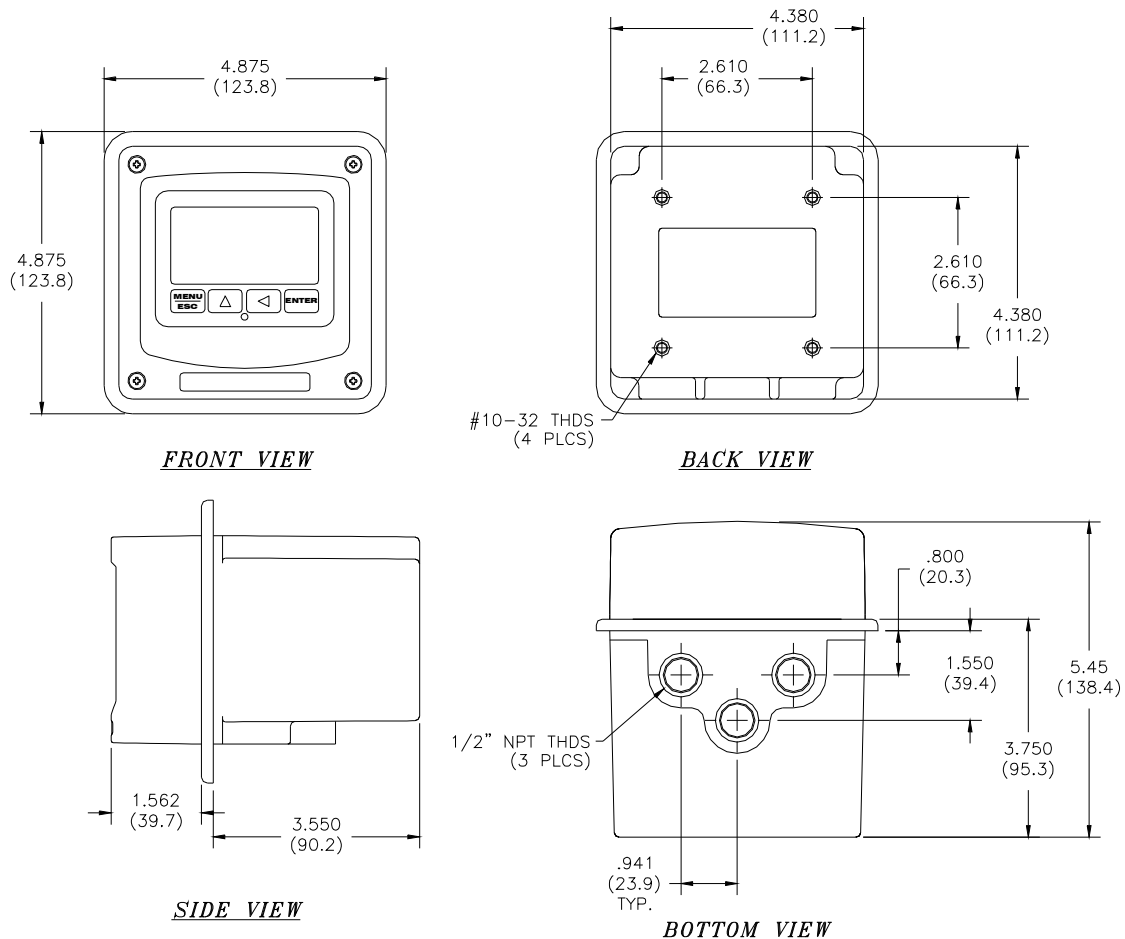

Figure 2 - Q45 Enclosure Dimensions

2.2 Wall or Pipe Mount Bracket

A PVC mounting bracket with attachment screws is supplied with each transmitter (see Figure 3 for dimensions). The multi-purpose bracket is attached to the rear of the enclosure using the four flat head screws. The instrument is then attached to the wall using the four outer mounting holes in the bracket. These holes are slotted to accommodate two sizes of u-bolt that may be used to pipe mount the unit. Slots will accommodate u-bolts designed for 1½" or 2" pipe. The actual center-to-center dimensions for the u-bolts are shown in the drawing. Note that these slots are for u-bolts with ¼-20 threads. The 1½" pipe u-bolt (2" I.D. clearance) is available from ATI in type 304 stainless steel under part number 47-0005

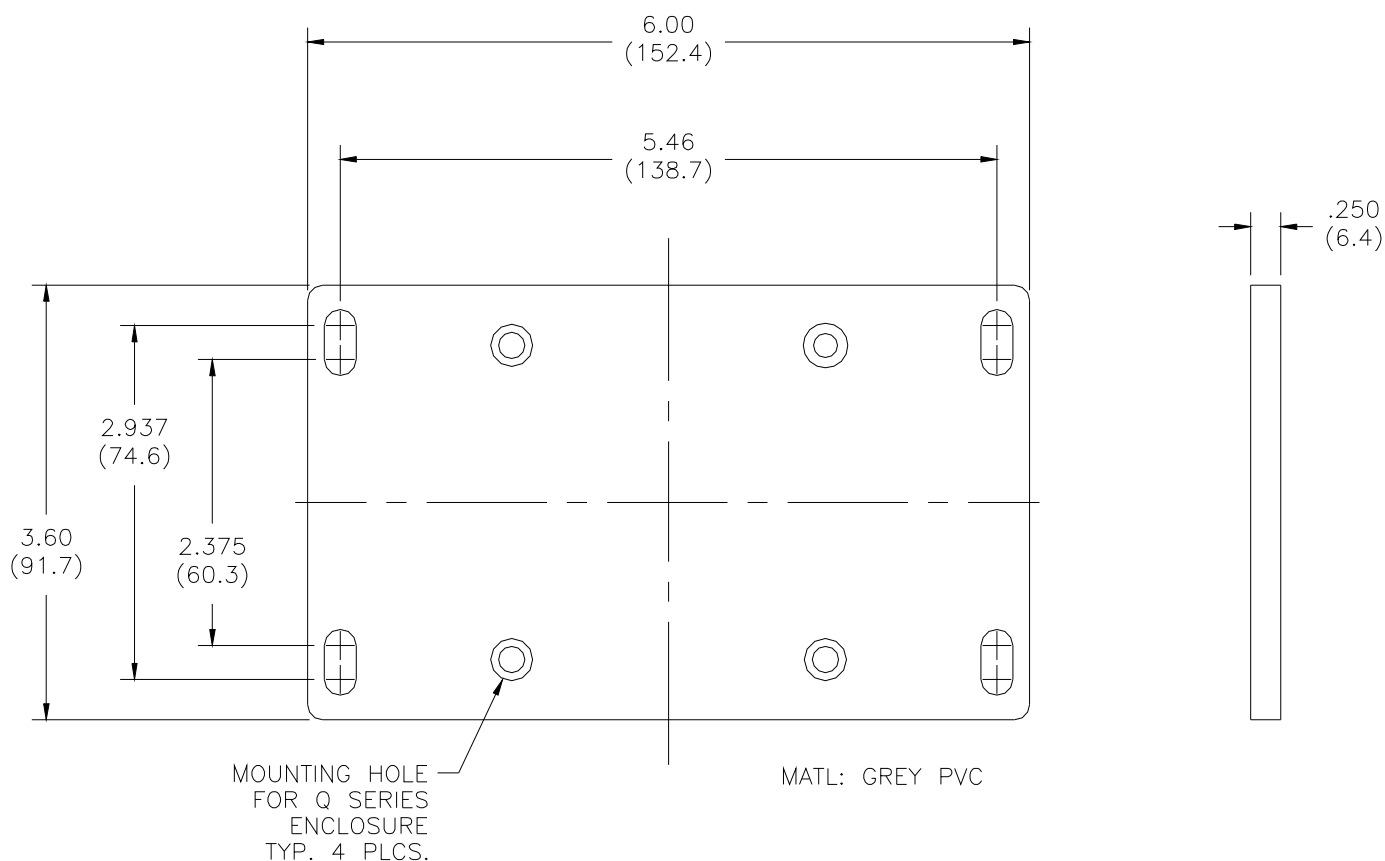

Figure 3 - Wall or Pipe Mount Bracket

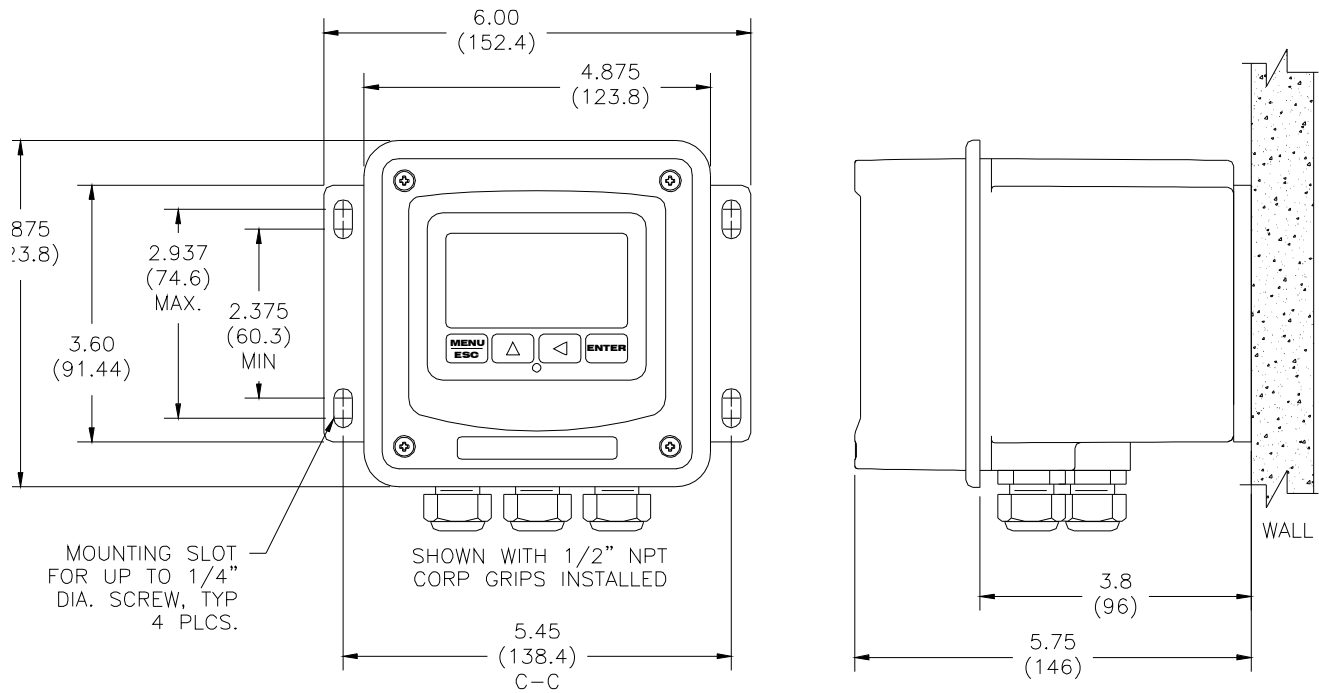

Figure 4 - Wall Mounting Diagram

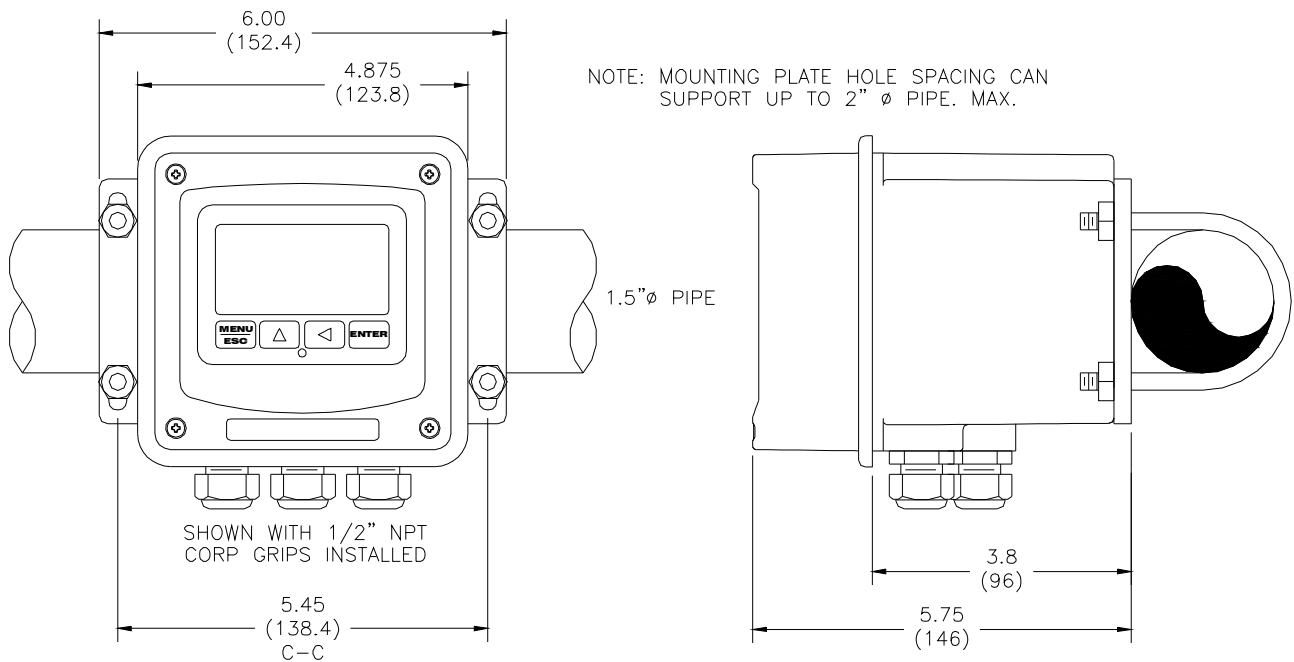

Figure 5 - Pipe Mounting Diagram

2.3 Panel Mount

Panel mounting of a monitor uses the panel-mounting flange molded into the rear section of the enclosure. Figure 6 provides dimensions for the panel cutout required for mounting.

The panel mounting bracket kit is ordered separately (part #05-0068). This kit contains a metal retainer bracket that attaches to the rear of the enclosure, 4 screws for attachment of this bracket, and a sealing gasket to insure that the panel mounted monitor provides a watertight seal when mounted to a panel.

The sealing gasket must first be attached to the enclosure. The gasket contains adhesive on one side so that it remains in place on the enclosure. Remove the protective paper from the adhesive side of the gasket and slide the gasket over the back of the enclosure so that the adhesive side lines up with the back of the enclosure flange. Once in place, proceed to mount the monitor in the panel.

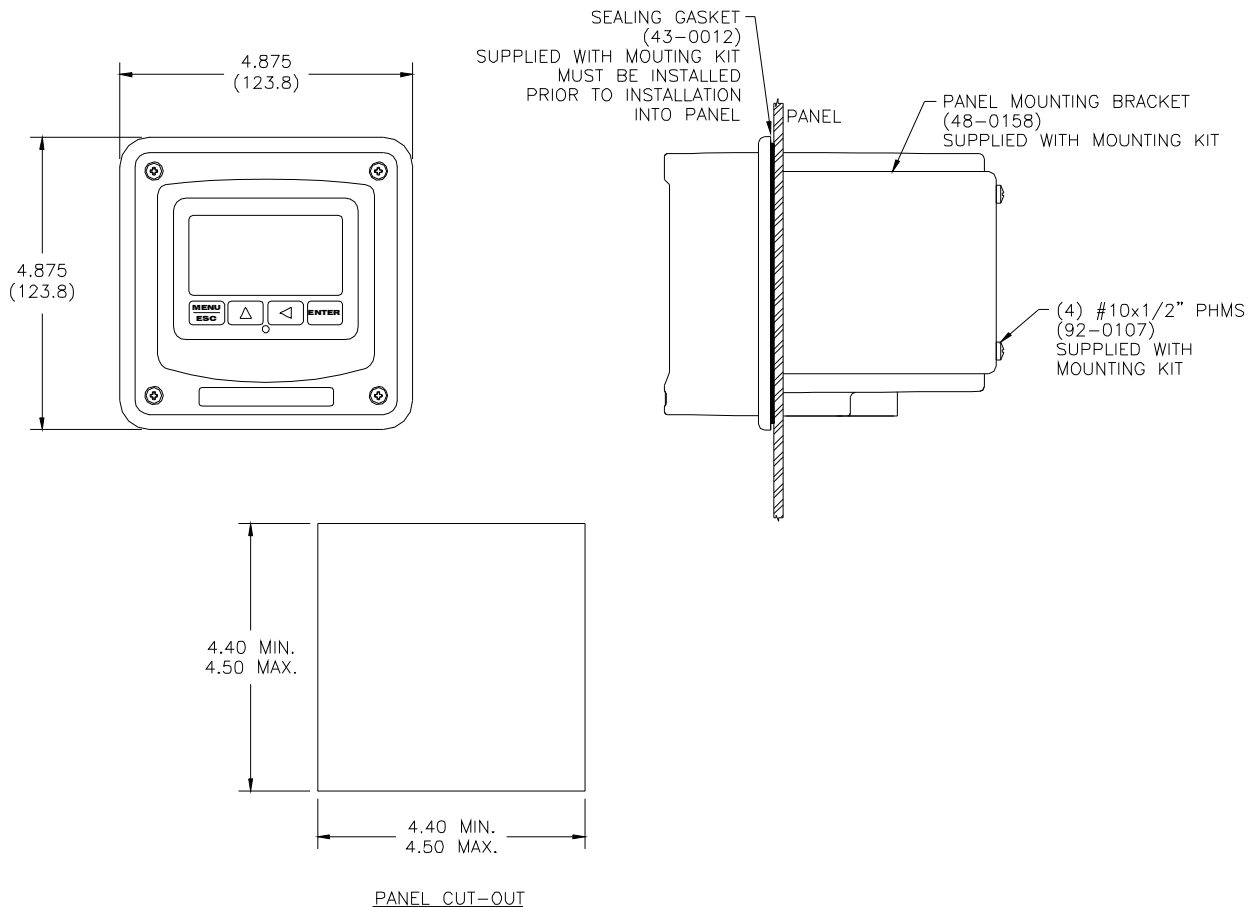

Figure 6 - Panel Mount (Cutout)

2.4 Chemistry Module

The chemistry module consists of an ABS enclosure housing sample and reagent pumps plus the air supply and reactor system used to measure permanganate concentration. The chemistry module is designed for wall mounting in a protected location. Although the enclosure is suitable for outdoor use, it is best to provide an additional enclosure around this module if mounted outdoors. Dimensions of this unit are shown in Figure 7..

NOTE: The chemistry module internal compartment must be accessible for wiring and service. The enclosure is hinged on the right side, and clearance must be allowed for the front section of the enclosure to swing open to the right. Allow a minimum of 6” (150 mm) clearance on the right side of the chemistry module for proper access to the internal compartment.

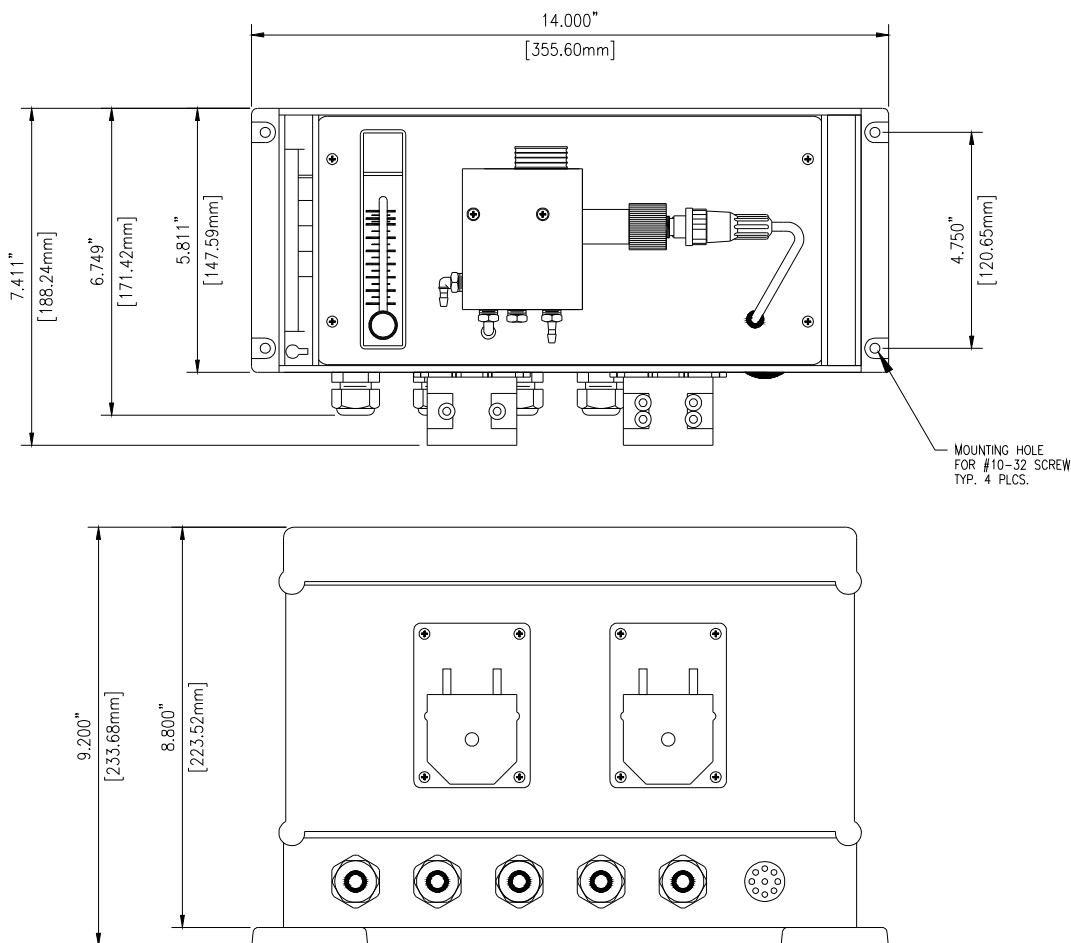

Figure 7 - Chemistry Module Dimensions

2.5 Sample Inlet Overflow

The water sample supplied to the monitor is connected to a special overflow chamber. This is done to insure that the sample flow rate to the monitor is sufficient to insure that fresh sample is always available at the sample pickup point. Most of the sample flowing to this assembly will simply go directly to the drain.

Figure 8 shows the sample overflow assembly with bracket. The bracket is supplied to hold the inlet assembly under the sample pump, and to allow waste from the chemistry module to flow back into the drain chamber. The overflow assembly should be mounted close to the chemistry module (as shown in Figure 8) to minimize system response time. Mounting further from the chemistry module will increase the sample transport time, thereby increasing the monitor response time. Once mounted, the sample pickup tube should be placed into the inlet chamber and the chemistry module drain tube should be placed into the drain chamber as shown.

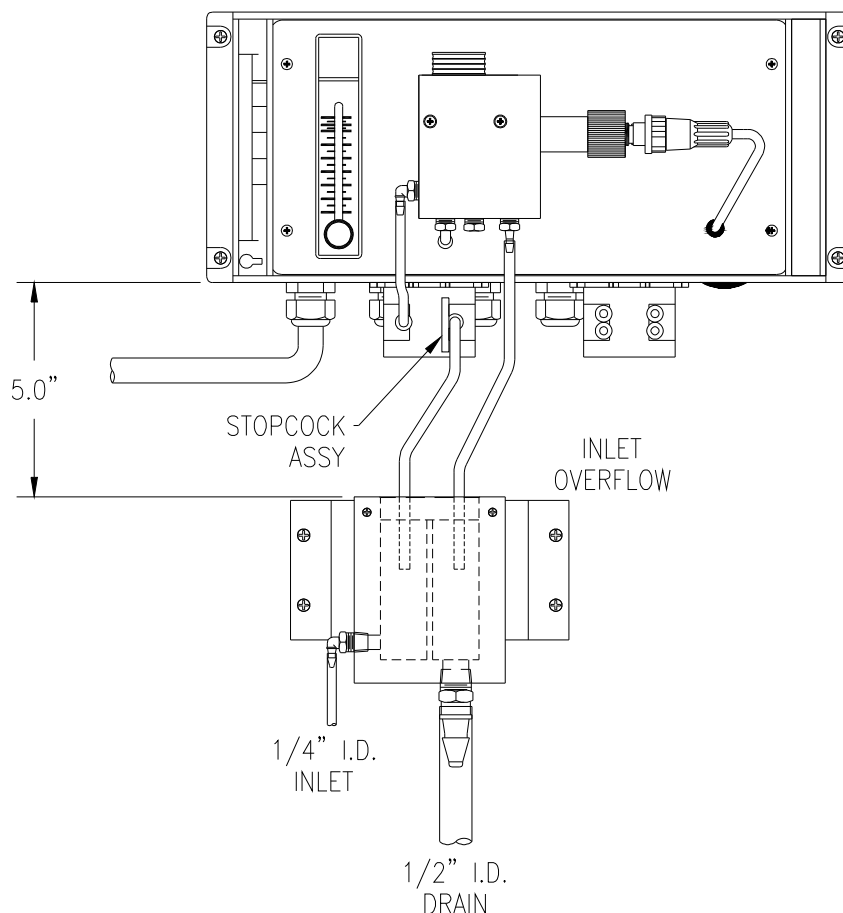

Figure 8 - Sample Inlet Overflow Location

2.6 Reagent Bottle Brackets

Two reagent bottle mounting bracket are supplied so that the buffer and KI solution can be located conveniently below the chemistry module. The brackets are designed for wall mounting, and will hold one gallon plastic containers. When mounting these brackets, be sure to leave enough room between the bottom of the chemistry module and the top of the bracket so that the bottles can be lifted from the brackets. **Note that these brackets are not supplied when the stainless steel mounting panel containing the reagent shelf is ordered with the analyzer.**

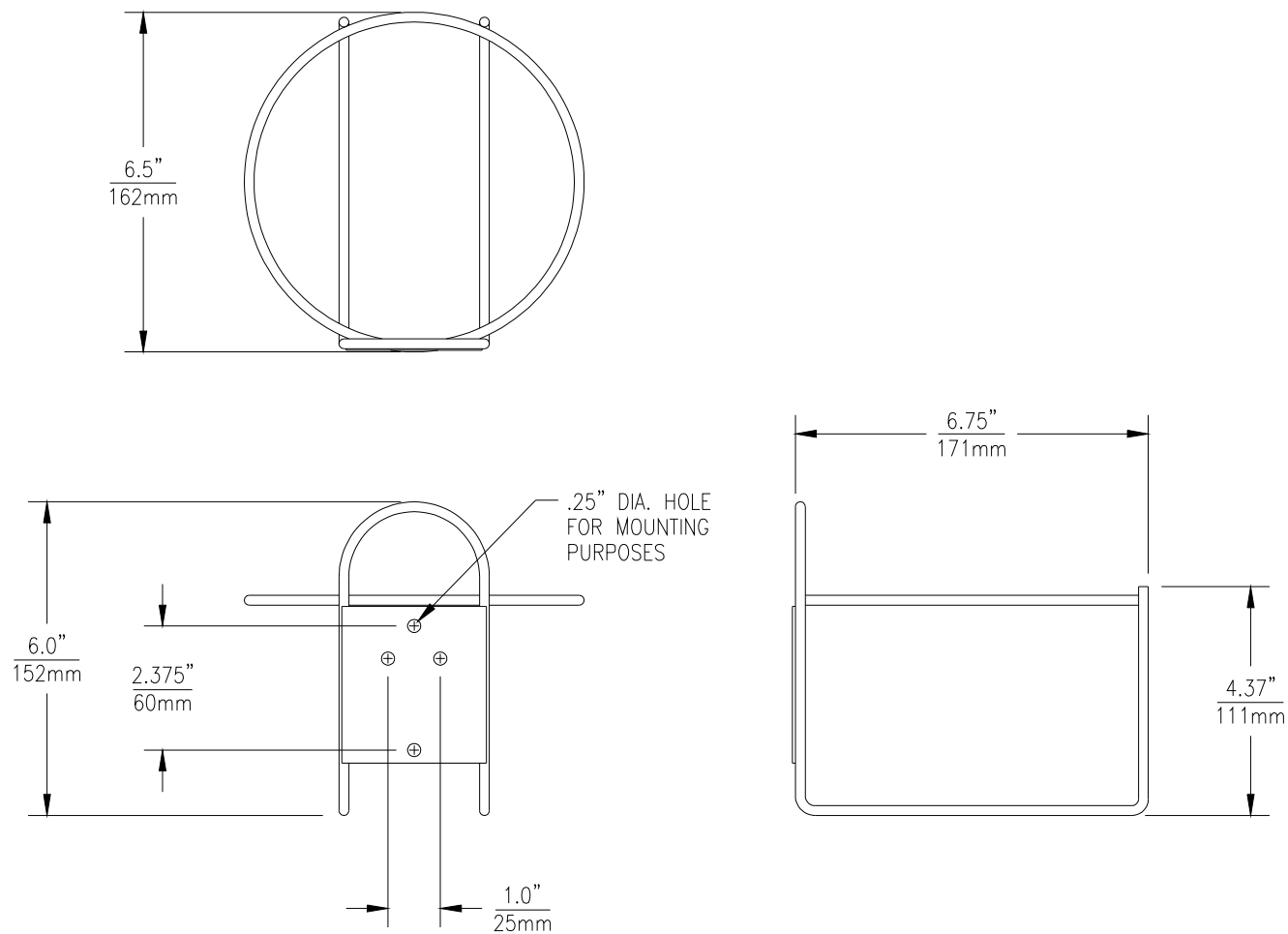

Figure 9 - Reagent Bottle Brackets

2.7 Reagent Pickup Assembly

A special rubber stopper with a ceramic support tube is supplied for each of the reagent bottles. If necessary, adjust the ceramic tube so that it does not hit the bottom of the solution bottles. A length of pickup tubing is also supplied for each of these pickup assemblies with a small filter attached to one end of the tubing. After the KI and vinegar solutions are ready, feed the end of the tubing opposite the filter up through the ceramic tube. Then insert the tube assembly into the solution and press the rubber stopper in place. When assembled, the reagent delivery system should conform to Figure 10.

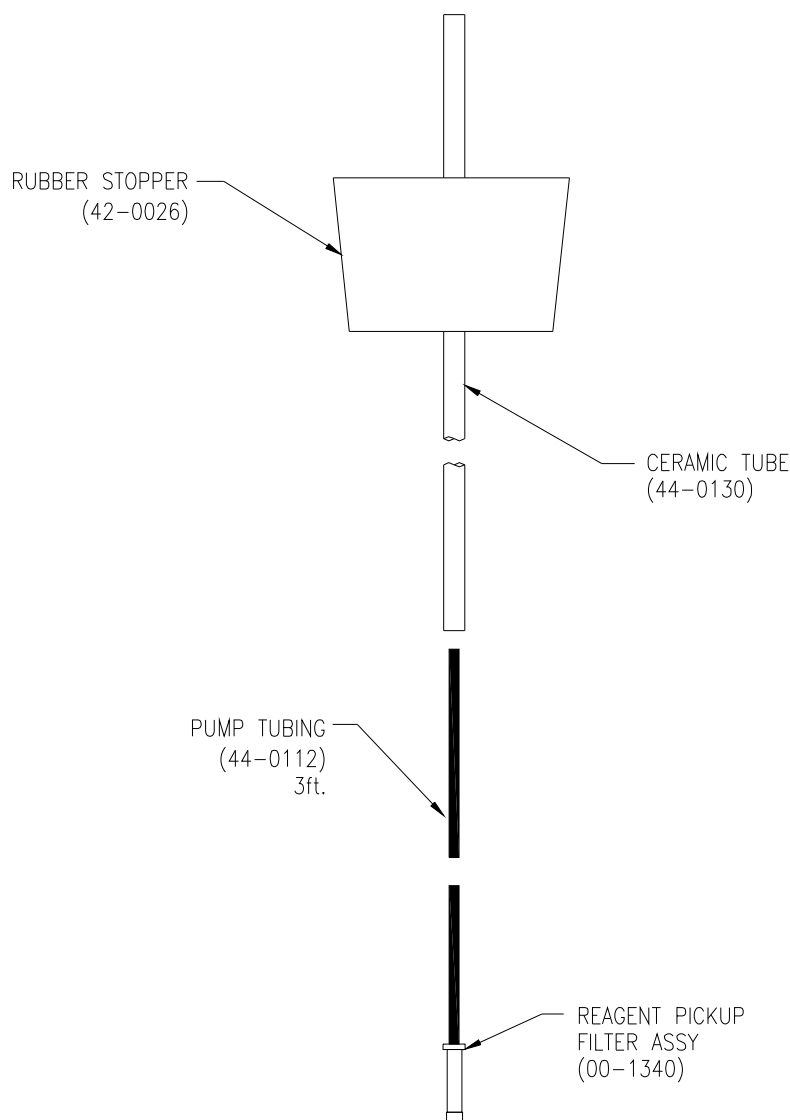

Figure 10 - Reagent Pickup Assembly

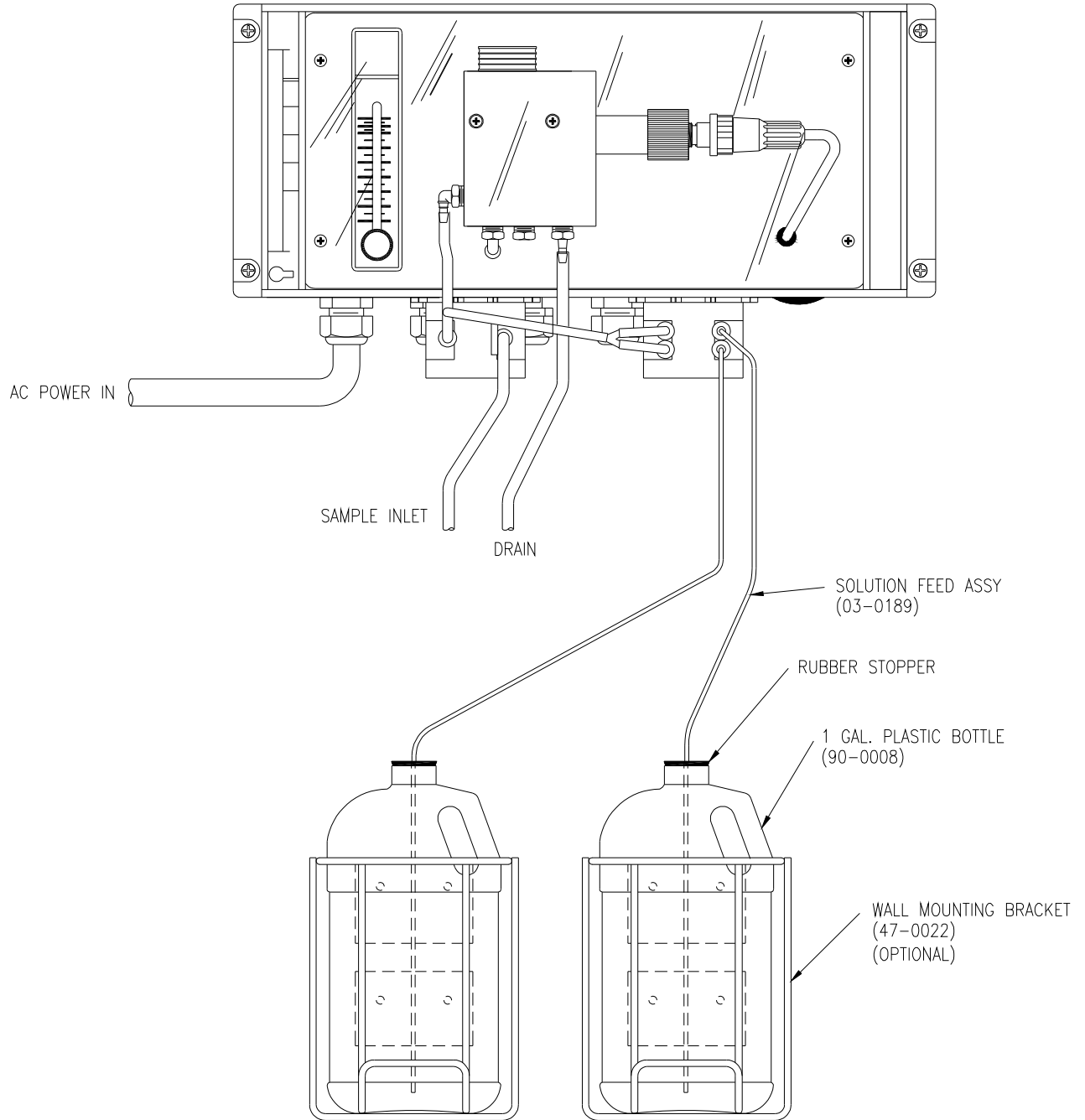

Figure 11 - Complete Reagent Feed Assembly

Part 3 – Electrical Installation

3.1 General

The Q45/83 requires either 115 or 230 VAC line power. Please verify the type of unit before connecting any power. AC power must be supplied to both the chemistry module and the electronic unit. Note that the chemistry module contains terminals for connection of AC power between the electronic monitor and the chemistry unit. Connection of the electronic monitor to these terminals allows for only one AC power input for the system. Alternatively, separate power feeds may be connected to the electronic monitor and chemistry module.

Important Notes:

1. Use wiring practices that conform to all national, state and local electrical codes. For proper safety as well as stable measuring performance, it is important that the earth ground connection be made to a solid ground point from terminal 12 (Figure 12). The AC power supply contains a single slo-blo fuse. The fuse is located adjacent to **TB5** and is easily replaceable.
2. Do NOT run sensor cables or instrument 4-20 mA output wiring in the same conduit that contains AC power wiring. AC power wiring should be run in a dedicated conduit to prevent electrical noise from coupling with the instrumentation signals.
3. This analyzer must be installed by specifically trained personnel in accordance with relevant local codes and instructions contained in this operating manual. Observe the analyzer's technical specifications and input ratings. Proper electrical disconnection means must be provided prior to the electrical power connected to this instrument, such as a circuit breaker - rated 250 VAC, 2 A minimum. If one line of the line power mains is not neutral, use a double-pole mains switch to disconnect the analyzer.

3.2 Monitor Power Connection

A DC power supply is mounted into the inside rear of the enclosure. The power supply must be ordered with the proper operating voltage. Verify that the unit requires either 115 VAC or 230 VAC before installing. Also verify that power is fully disconnected before attempting to wire.

Q45/83 electronic monitors are supplied with 3 cable gland fittings and two ½” conduit adapters. One of the cable glands has a larger hole in the rubber gland and should be used for the power cord entry if a flexible power cord will be used for installation. One of the cable glands with the smaller gland opening should normally be used for the sensor cable. Cable glands and conduit hubs will screw into any of the three threaded holes on the bottom of the enclosure.

Connect HOT, NEUTRAL, and GROUND to the matching designations on terminal strip **TB5**.

WARNING

Disconnect line power voltage BEFORE connecting line power wires to Terminal TB5 of the power supply. The power supply accepts only standard three-wire single phase power. The power supply is configured for 115 VAC or 230 VAC operation at the factory at time of order, and the power supply is labeled as such. Do NOT connect voltages other than the labeled requirement to the input.

The analog outputs from the system are present at terminals TB1 and TB2. The loop-load limitation in this configuration is 500 Ohms maximum for each output. Also note that these two outputs are completely isolated from each other to insure that ground loops do not result from the connection of both outputs to the same device such as a PLC or DCS.

A ribbon cable connects the power supply assembly with the microprocessor assembly located in the front section of the enclosure. This cable can be removed during installation to facilitate wiring if desired. It is best to unplug only one end. The ribbon cable has a marking stripe on one edge that is used to indicate proper orientation. The indicator stripe should be on the bottom edge of the cable when installed as shown in Figure 12.

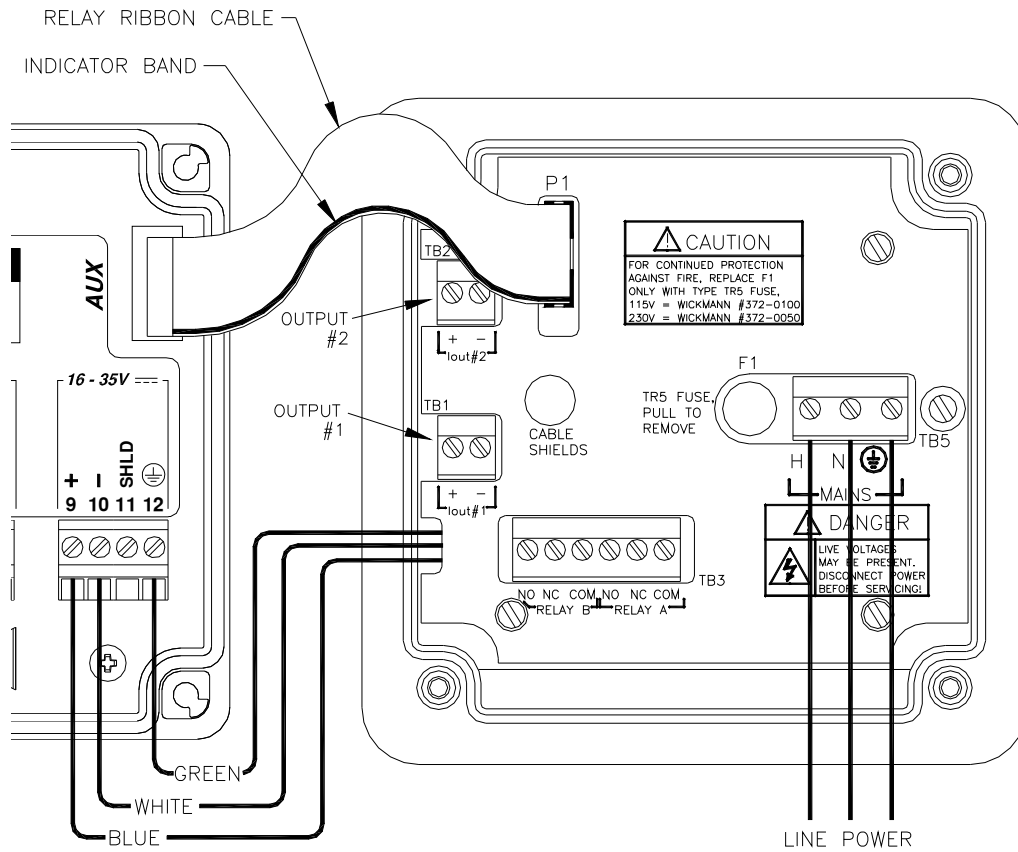

Figure 12 - Line Power Connection

The power strip, **TB5**, allows up to 12 AWG wire. A wire gauge of 16 AWG is recommended to allow for an easy pass-through into the M16 ports when wiring.

Two sets of SPDT relay contacts are provided on the power supply board. None of the relay contacts are powered. The user must supply the proper power to the contacts. For applications that require the same switched operating voltage as the Q45 (115 or 230 V), power may be jumpered from the power input terminals at **TB5**. Relay wiring is connected at **TB3** as shown below. Note that the relay contact markings are shown in the NORMAL mode. Programming a relay for “Failsafe” operation reverses the NO and NC positions in this diagram.

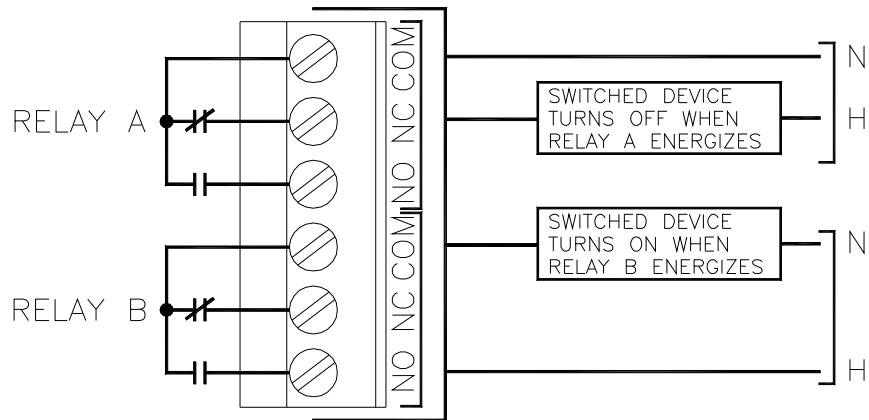

Figure 13 - Relay Contacts

3.3 Chemistry Module Power Connection

The chemistry module power requirements are the same as the monitor. Power connections are made at the terminals shown in Figure 14 below.

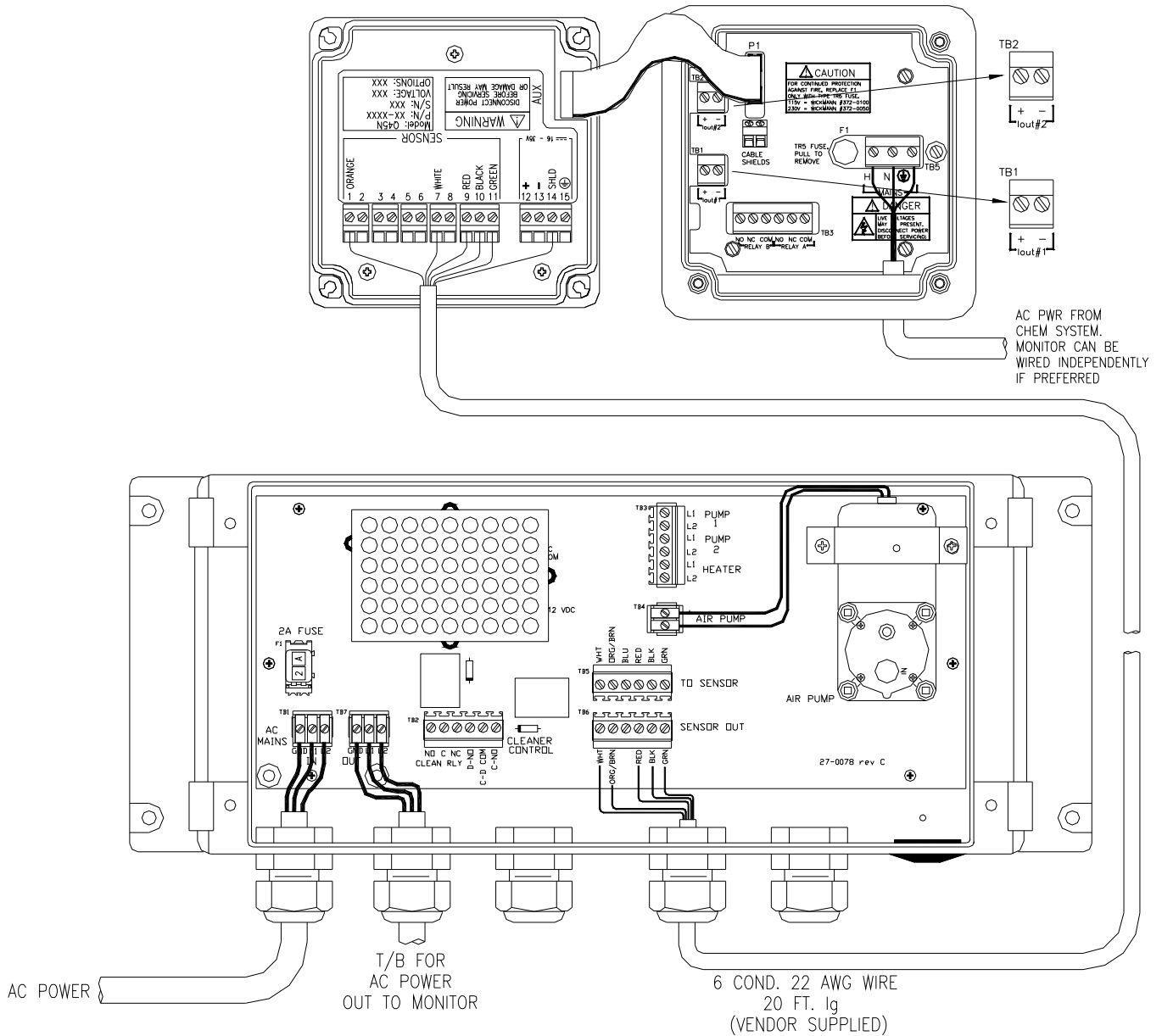

Figure 14 - Chemistry Module Electrical Connections

Part 4 – Chemistry System

4.1 Chemistry Module

The chemistry module is the heart of the permanganate monitor. Inside this module are the pumps, air supply, air control instruments, and sensor element required to make an accurate measurement. All items are housed in a protective enclosure, with the main components mounted on the front panel inside the clear cover. The front section of the enclosure is hinged in two places, with the clear cover able to swing in either direction. The center compartment is allowed to swing open on the right hand hinge only (open left release latch). Opening the center compartment allows access to the terminal circuit board, air pump, and sample and reagent pump wiring.

KMnO₄ measurement module is done by pumping a small amount of sample out of the inlet overflow chamber, mixing the sample with buffer and KI solution to convert permanganate to iodine, and then air stripping the I₂ for measurement in the gas phase. Figures 14 and 15 provide a view of the chemistry module components.

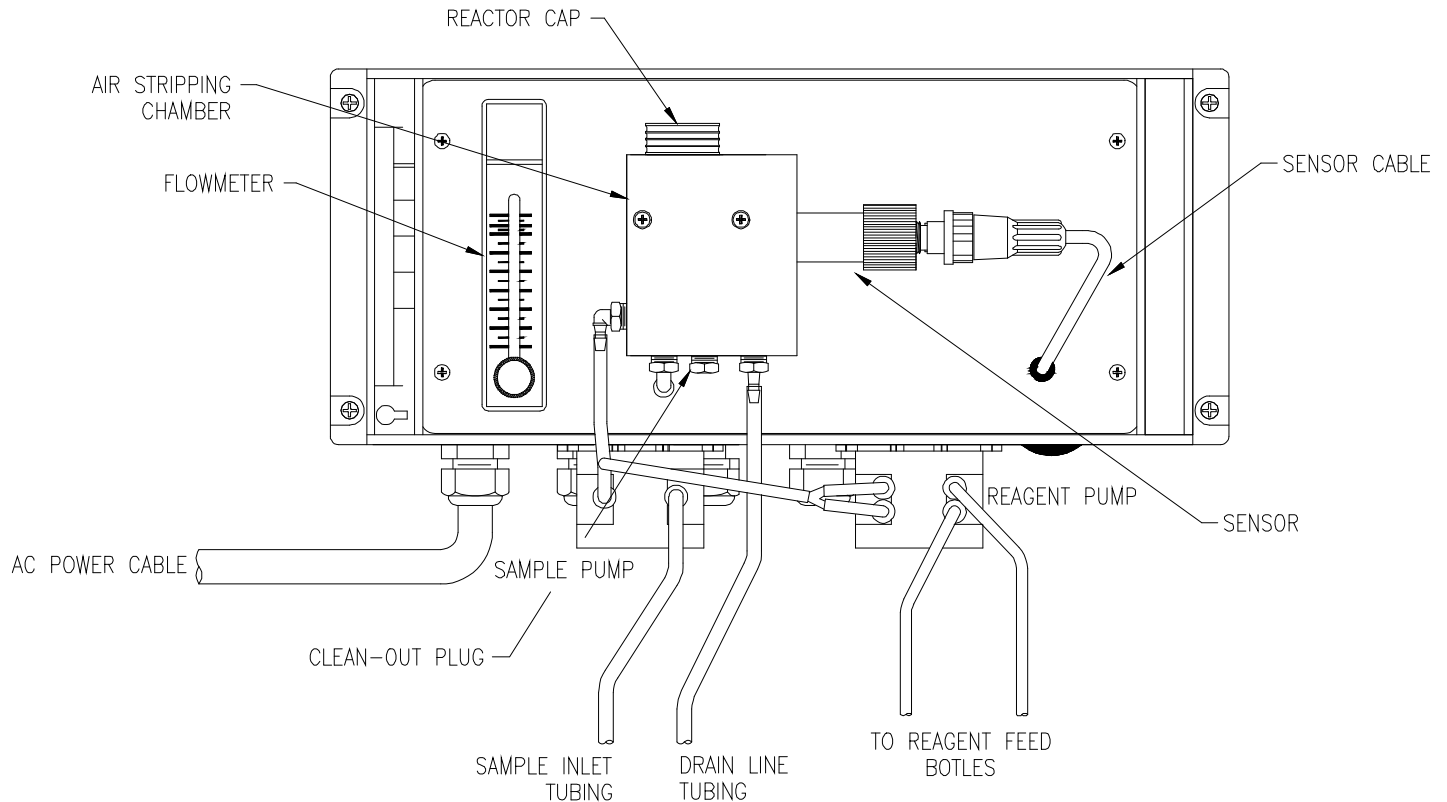
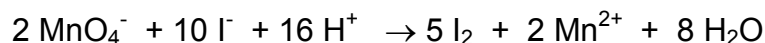

Figure 15 - Chemistry Module Components

4.2 Chemistry System Function

In operation, sample flows to the inlet chamber of the overflow assembly. Most of the sample overflows to waste. A small amount of sample (5 cc/min.) is pumped out of the inlet chamber. Both acetic acid buffer and potassium iodide solution are supplied by the second pump and mixed with the sample in the mixing “T”, converting the permanganate in solution to molecular iodine gas as follows.



The reacted sample then moves to the air stripping chamber. In the stripping chamber, air is injected into the incoming sample at a controlled rate. Iodine gas is stripped from the sample into this air stream and carried through a passage in the top of the reactor past the sensor that is inserted into a separate chamber in the side of the reactor. A special iodine gas sensor located in this flow chamber measures the iodine concentration, providing a signal to the electronics module.

Air for the stripping process is provided by an air pump located on the circuit board in the rear compartment of the chemistry module. Air from this pump is first filtered and then pumped through a rotameter with flow indicator. The rotameter is used to adjust the flow of stripping air to the rate required for the measurement, and should always be set to 400 cc/min. A check valve in the outlet of the air supply line prevents sample from flowing back into the air supply system.

Reacted sample from the stripping chamber flows through a liquid trap and into a drain chamber which is directly below the sensor. The stripping air and the reacted sample both exit through a tube at the bottom of the reactor and are directed into the drain side of the inlet overflow assembly as shown in Figure 8.

4.3 Sensor Preparation

The iodine gas sensor is shipped with a protective membrane but with no electrolyte inside. A new membrane and electrolyte must be installed in the sensor prior to operation. In addition, the membrane and internal electrolyte need replacement on 2-3 month schedule. Iodine sensors are three part assemblies as shown in Figure 16. Replacement membranes are supplied in boxes of 10 precut disks. The following procedure must be followed exactly to insure proper sensor operation.

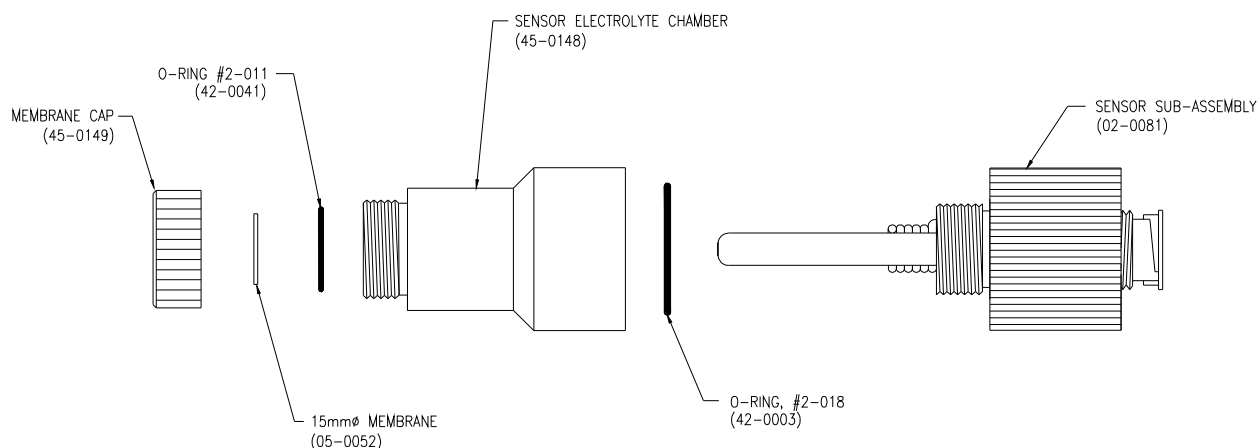

Figure 16 - Sensor Assembly

Follow the procedure below to prepare the sensor for operation:

1. Unscrew the electrolyte chamber from the body of the sensor. Discard the electrolyte inside.
2. Unscrew the membrane cap from the end of the electrolyte chamber and push out and discard the old membrane.
3. From the membrane container, carefully remove a white disc and place it in the membrane cap. **Handle membranes only with clean hands.** Place the membrane into the cap and carefully push it down so that it lies flat in the cap.
4. Check the end of the electrolyte chamber to be sure the o-ring is seated properly. Then screw the membrane cap onto the electrolyte chamber. Pour electrolyte into the chamber until the level is about $\frac{1}{4}$ " from the top.
5. Slowly screw the electrolyte chamber onto the sensor body. A small amount of electrolyte will run out the top, so it's best to do this over a sink.
6. Wipe excess electrolyte from the sides of the sensor, insert it into the flow chamber on the side of the reactor, and plug the sensor cable into the back.

CAUTION: The electrolyte used in this sensor will not harm your skin, but should be rinsed off after the sensor is assembled. Do not get electrolyte in your eyes as it will cause stinging. If eye contact occurs, flush with large amounts of water. Electrolyte can cause discoloration of clothing, so avoid getting the liquid on your garments.

4.4 Sensor Installation

Once the sensor has been prepared for use, it simply slides into the sensor location in the air stripping block. An o-ring seals the sensor into the block. A small amount of O-ring lubricant can be used on this o-ring to make sensor insertion and removal easier. A quick disconnect cable plugs into the back of the sensor.

4.5 Reagent Preparation

The Q45/83 requires two reagents for normal operation. These are designated Reagent A and Reagent B. These reagents are prepared on site and are stable for at least 3 months. One gallon of each will operate the system for approximately 45 days.

Reagent A

Reagent A is used to buffer the sample. This reagent is simply a 5% solution of acetic acid. For normal operation, we recommend the use of common white vinegar available from most supermarkets. The chemical is inexpensive and widely available. If preferred, a 5% solution of acetic acid can be mixed by the plant laboratory from reagent grade acetic acid.

Reagent B

Reagent B is a solution consisting of 50 grams of reagent grade potassium iodide to which 1 kernel of potassium hydroxide has been added for stability. Supplied with the Q45/83 is a container of potassium iodide for mixing 1 gallon of reagent B. Fill one of the reagent bottles about $\frac{3}{4}$ full with distilled water and dump the contents of #09-0031 KI reagent into the container. Mix to dissolve the KI and then fill to the top with distilled water.

Mark this bottle "Reagent B" and place the reagent pickup assembly into the mouth of the bottle.

Part 5 – Configuration

5.1 User Interface

The user interface for the Q45 Series instrument consists of a custom display and a membrane keypad. All functions are accessed from this user interface (no internal jumpers, pots, etc.).

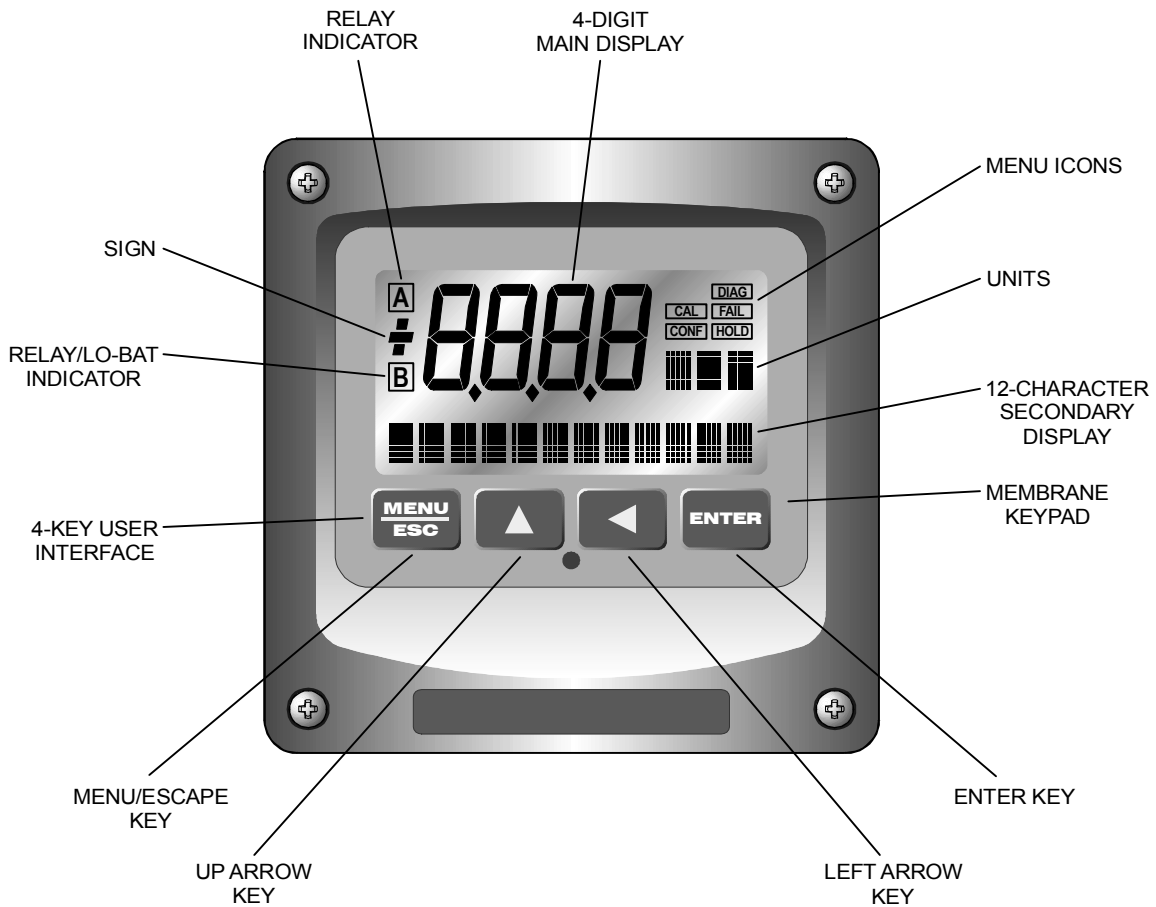

Figure 17 - User Interface

5.11 Keys

All user configurations occur through the use of four membrane keys. These keys are used as follows:

- | | |
|---------------------|---|
| MENU/ESC | To scroll through the menu section headers or to escape from anywhere in software. The escape sequence allows the user to back out of any changes in a logical manner. Using the escape key aborts all changes to the current screen and backs the user out one level in the software tree. The manual will refer to this key as either MENU or ESC, depending upon its particular function. In the battery-powered version of the Q45, this is also the ON button. |
| UP (arrow) | To scroll through individual list or display items and to change number values. |
| LEFT (arrow) | To move the cursor from right to left during changes to a number value. |
| ENTER | To select a menu section or list item for change and to store any change. |

5.12 Display

The large custom display provides clear information for general measurement use and user configuration. There are three main areas of the display: the main parameter display, the secondary message line, and the icon area.

- | | |
|-----------------------|--|
| Main Parameter | During normal operation, the main parameter display indicates the present process input with sign and units. This main display may be configured to display any of the main measurements that the system provides. During configuration, this area displays other useful set-up information to the user. |
|-----------------------|--|

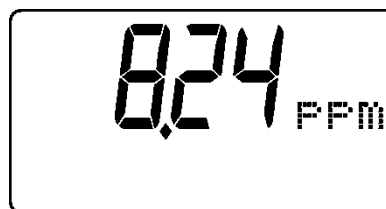

Lower Line

During normal operation, the lower line of the display indicates user-selected secondary measurements that the system is making. This also includes calibration data from the last calibration sequence and the transmitter model number and software version. During configuration, the lower line displays menu items and set-up prompts to the user. Finally, the lower line will display error messages when necessary. For a description of all display messages, refer to Section 9.5.



Icon Area

The icon area contains display icons that assist the user in set-up and indicate important states of system functions. The CAL, CONFIG, and DIAG icons are used to tell the user what branch of the software tree the user is in while scrolling through the menu items. This improves software map navigation dramatically. Upon entry into a menu, the title is displayed (such as CAL), and then the title disappears to make way for the actual menu item. However, the icon stays on.



HOLD

The HOLD icon indicates that the current output of the transmitter has been put into output hold. In this case, the output is locked to the last input value measured when the HOLD function was entered. HOLD values are retained even if the unit power is cycled.

FAIL

The FAIL icon indicates that the system diagnostic function has detected a problem that requires immediate attention. This icon is automatically cleared once the problem has been resolved.

Relay Area A/B

The relay area contains two icons that indicate the state of the system relays (if the relay card is installed). If the battery board is installed instead, the B icon indicates that the battery voltage is at a low level. The battery power option and the relay option cannot be installed together.

**5.2 Software**

The software of the Q45H is organized in an easy to follow menu-based system. All user settings are organized under five menu sections: Measure, Calibration [CAL], Configuration [CONFIG], Control [CONTROL] and Diagnostics [DIAG].

Note: The default Measure Menu is display-only and has no menu icon.

5.21 Software Navigation

Within the CAL, CONFIG, CONTROL, and DIAG menu sections is a list of selectable items. Once a menu section (such as CONFIG) has been selected with the MENU key, the user can access the item list in this section by pressing either the ENTER key or the UP arrow key. The list items can then be scrolled through using the UP arrow key. Once the last item is reached, the list wraps around and the first list item is shown again. The items in the menu sections are organized such that more frequently used functions are first, while more permanent function settings are later in the list. See Figure 18 for a visual description of the software.

Each list item allows a change to a stored system variable. List items are designed in one of two forms: simple single variable, or multiple variable sequences. In the single variable format, the user can quickly modify one parameter - for example, changing temperature display units from °F to °C. In the multiple variable sequence, variables are changed as the result of some process. For example, the calibration of permanganate generally requires more than one piece of information to be entered. The majority of the menu items in the software consist of the single variable format type.

Any data that may be changed will be flashing. This flashing indicates user entry mode and is initiated by pressing the ENTER key. The UP arrow key will increase a flashing digit from 0 to 9. The LEFT arrow key moves the flashing digit from right to left. Once the change has been completed, pressing ENTER again stores the variable and stops the flashing. Pressing ESC aborts the change and also exits user entry mode.

The starting (default) screen is always the Measure Menu. The UP arrow key is used to select the desired display. From anywhere in this section the user can press the MENU key to select one of the four Menu Sections.

The UP arrow icon next to all list items on the display is a reminder to scroll through the list using the UP arrow key.

To select a list item for modification, first select the proper menu with the MENU key. Scroll to the list item with the UP arrow key and then press the ENTER key. This tells the system that the user wishes to perform a change on that item. For single item type screens, once the user presses the ENTER key, part or all of the variable will begin to flash, indicating that the user may modify that variable using the arrow keys. However, if the instrument is locked, the transmitter will display the message **Locked!** and will not enter user entry mode. The instrument must be unlocked by entering the proper code value to allow authorized changes to user entered values. Once the variable has been reset, pressing the ENTER key again causes the change to be stored and the flashing to stop. The message **Accepted!** will be displayed if the change is within pre-defined variable limits. If the user decides not to modify the value after it has already been partially changed, pressing the ESC key aborts the modification and returns the entry to its original stored value.

In a menu item which is a multiple variable sequence type, once the ENTER key is pressed there may be several prompts and sequences that are run to complete the modification. The ESC key can always be used to abort the sequence without changing any stored variables.

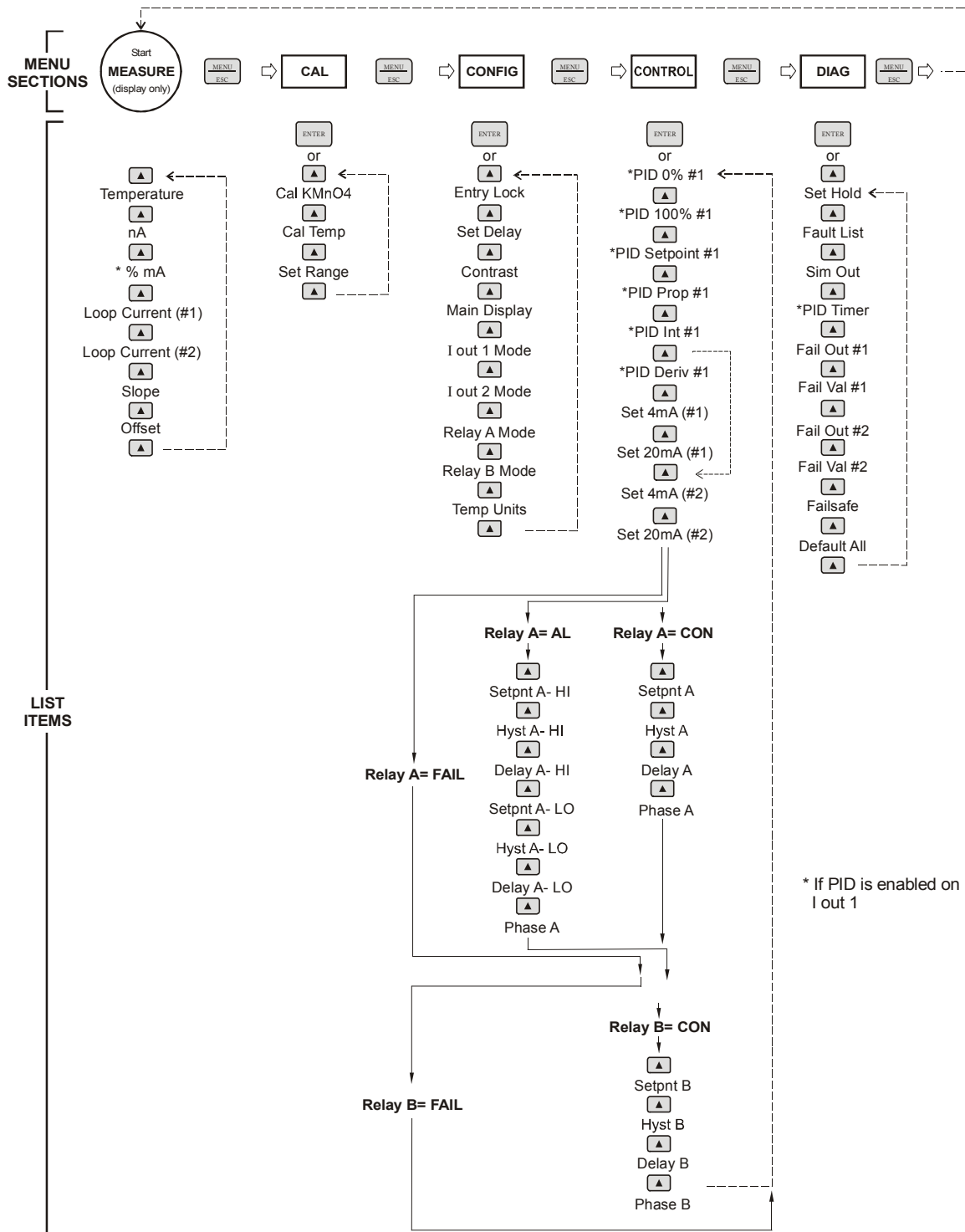

Figure 18 - Software Map

5.22 Measure Menu [MEASURE]

The default menu for the system is the display-only menu MEASURE. This menu is a display-only measurement menu, and has no changeable list items. When left alone, the instrument will automatically return to this menu after approximately 30 minutes. While in the default menu, the UP arrow allows the user to scroll through the secondary variables on the lower line of the display. A brief description of the fields in the basic transmitter version is as follows:

TRANSMITTER MEAS SCREENS:

25.7C	Temperature display. Can be displayed in C or F, depending on user selection. A small “m” on the left side of the screen indicates the transmitter has automatically jumped to a manual 25C setting due to a failure with the temperature signal input.
32.0 nA	Raw sensor current. Useful for diagnosing problems.
100% 20.00 mA	PID Status screen (if enabled.) Shows the present controller output level on left, and actual transmitter current on the right. The controller can be placed in manual while viewing this screen by pressing and holding the ENTER key for 5 seconds until a small flashing “m” appears on the screen. At that point the controller output can be adjusted up or down using the UP and LEFT arrow keys. To return to automatic operation, press and hold the ENTER key for 5 seconds and the “M” will disappear.
4.00 mA	Transmitter output current # 1.
20.00 mA	Transmitter output current # 2.
Slope = 100%	Sensor output response vs. ideal calibration. This value updates after each calibration. As the sensor ages, the slope reading will decay indicating sensor aging. Useful for resolving sensor problems.
Offset = 0.0 nA	Sensor output current at a zero ppm input. This value updates after a zero-calibration has been performed. Useful for resolving sensor problems.
Q45H v4.02	Transmitter software version number.

The MEASURE screens are intended to be used as a very quick means of looking up critical values during operation or troubleshooting.

Note: A display test (all segments ON) can be actuated by pressing and holding the ENTER key while viewing the model/version number on the lower line of the display.

The MEASURE screens are intended to be used as a very quick means of looking up critical values during operation or troubleshooting.

5.23 Calibration Menu [CAL]

The calibration menu contains items for frequent calibration of user parameters. There are four items in this list: Cal CL2, Cal Temp, Set Range, and Cal Zero.

Cal KMnO₄ The calibration function allows the user to adjust the transmitter span reading to match a reference solution, or to set the sensor zero point. See Part 6 - Calibration for more details.

Cal Temp The temperature calibration function allows the user to adjust the offset of the temperature response by a small factor of ± 5 °C. The temperature input is factory calibrated to very high accuracy. However, long cable lengths and junction boxes may degrade the accuracy of the temperature measurement in some extreme situations. Therefore, this feature is provided as an adjustment. See Part 6 - Calibration for more details.

Set Range This function allows the user to set the display range of the transmitter to a specific application. Once set, all output functions use this display range to establish configuration settings. Press ENTER to initiate user entry mode, and the value will flash. Use the arrow keys to modify value; available ranges include 2.000 ppm and 20.00 ppm. Press ENTER to store the new value. The display range does not affect the internal auto ranging scaler and, therefore, sensitivity is to specification in any user selected range.

5.24 Configuration Menu [CONFIG]

The Configuration Menu contains all of the general user settings:

Entry Lock

This function allows the user to lock out unauthorized tampering with instrument settings. All settings may be viewed while the instrument is locked, but they cannot be modified. The Entry Lock feature is a toggle-type setting; that is, entering the correct code will lock the transmitter and entering the correct code again will unlock it. The code is preset at a fixed value. Press ENTER to initiate user entry mode and the first digit will flash. Use arrow keys to modify value. **See Page 70 for the Q45H lock/unlock code.** Press ENTER to toggle lock setting once code is correct. Incorrect codes do not change state of lock condition.

Set Delay

The delay function sets the amount of damping on the instrument. This function allows the user to apply a first order time delay function to the measurements being made. Both the display and output value are affected by the degree of damping. Functions such as calibration are not affected by this parameter. The calibration routines contain their own filtering and stability monitoring functions to minimize the calibration timing. Press ENTER to initiate user entry mode, and the value will flash. Use the arrow keys to modify value; range is 0.1 to 9.9 minutes. Press ENTER to store the value.

Contrast

This function sets the contrast level for the display. The custom display is designed with a wide temperature range and provides the highest possible contrast and widest viewing angle under all conditions. Contrast control of this type of display is generally not necessary, so contrast control is provided as a means for possible adjustment due to aging at extreme ranges. The display contains a LED backlight for good visibility in the dark. Press ENTER to initiate user entry mode, and the value will flash. Use arrow keys to modify the value; range is 0 to 8 (0 being lightest). Press ENTER to update and store the new value.

Main Units

This function allows the user to select either PPM or mg/l for the permanganate measurement.

- Zero Filter** This function forces the reading to zero when reading is below the entered value. For example, If the entered value were 0.010 the display at 0.009 would then indicate 0.000. This feature is useful in blanking out zero noise.
- Main Display** This function allows the user to change the measurement in the primary display area. The user may select between permanganate, sensor temperature, or output current. Using this function, the user may choose to put temperature in the main display area and permanganate on the secondary, lower line of the display. Press ENTER to initiate user entry mode, and the entire value will flash. Use the UP arrow key to modify the desired display value. Press ENTER to store the new value.
- lout#1 Mode** This function sets analog output #1 to either track potassium permanganate (default) or enables the PID controller to operate on the KMnO_4 input. Press ENTER to initiate user entry mode, and the entire value will flash. Use the UP arrow key to modify the desired value; selections include 1-ppm for KMnO_4 tracking or 2-PID for PID control. Press ENTER to store the new value.
- lout#2 Mode** This function sets analog output #2 for either temperature (default) or KMnO_4 . Press ENTER to initiate user entry mode, and the entire value will flash. Use the UP arrow key to modify the desired value; selections include 1-C/F for temperature or 2-ppm for permanganate. Press ENTER to store the new value.
- Rly A Mode** Relay A can be used in three different ways: as a setpoint control, as a fail alarm, or as a HI-LO alarm band. The three settings for Rly A Mode are **CON**, **FAIL** and **AL**.
- The **CON** setting enables normal control operation for Relay A, with settings for setpoint, hysteresis, delay and phasing appearing in the CONFIG menu automatically. See Figure 19 for further details.
- The **FAIL** setting enables the fail alarm mode for Relay A. Relay A will then trip on any condition that causes the FAIL icon to be displayed on the LCD. Using this mode allows the User to send alarm indications to other remote devices.

The **AL** setting allows two setpoints to be selected for the same relay, producing a HI-LO alarm band. In this mode, Relay A will trip inside or outside of the band, depending upon the Phase selected. See Figure 20 for further details.

Relay B Mode

Relay B can be used in a number of ways: as a setpoint control, or as an alarm. The two settings for Relay B Mode are **CON** and **FAIL**.

The **CON** setting enables normal setpoint operation for Relay B. Relay B then operates identically to Relay A, with settings for setpoint, hysteresis, delay and phasing appearing in the CONFIG menu automatically. See Figure 19 for details.

The **FAIL** setting enables the fail alarm mode for Relay B. Relay B will then trip on any condition that causes the FAIL icon to be displayed on the LCD. Using this mode allows the User to send alarm indications to other remote devices. See Figure 20 for details.

Temp Units

This function sets the display units for temperature measurement. Press ENTER to initiate user entry mode, and the entire value will flash. Use the UP arrow key to modify the desired display value. The choices are °F and °C. Press ENTER to store the new value.

5.25 Control Menu [CONTROL]

The Control Menu contains all of the output control user settings:

Set 4 mA

Set 20 mA

[lout1=KMnO₄]

These functions set the main 4 and 20 mA current loop output points for the transmitter. The units displayed depend on the selection made in the CONFIG menu for lout #1 Mode.

The value stored for the 4 mA point may be higher or lower than the value stored for the 20 mA point. The entry values are limited to values within the range specified in “Set Range”, and the 4 mA and the 20 mA point must be separated by at least 1% of this range. Use the LEFT arrow key to select the first digit to be modified. Then use the UP and LEFT arrow keys to select the desired numerical value. Press ENTER to store the new value.

Set PID 0%
Set PID 100%
[lout1=PID]

If the PID is enabled, this function sets the minimum and maximum controller end points. Unlike the standard 4-20 mA output, the controller does not “scale” output values across the endpoints. Rather, the endpoints determine where the controller would normally force minimum or maximum output in an attempt to recover the setpoint (even though the controller can achieve 0% or 100% anywhere within the range.)

If the 0% point is lower than the 100% point, then the controller action will be “reverse” acting. That is, the output of the controller will increase if the measured value is less than the setpoint, and the output will decrease if the measured value is larger than the setpoint. Flipping the stored values in these points will reverse the action of the controller to “direct” mode.

The entry value is limited to a value within the range specified in “Set Range”, and the 0% and the 100% point must be separated by at least 1% of this range. Use the LEFT arrow key to select the first digit to be modified. Then use the UP and LEFT arrow keys to select the desired numerical value. Press ENTER to store the new value.

PID Setpnt
[lout1=PID]

The measured value which the controller is attempting to maintain by adjusting output value. It is the nature of the PID controller that it never actually gets to the exact value and stops. The controller is continually making smaller and smaller adjustments as the measured value gets near the setpoint.

PID Prop

[Iout1=PID]

Proportional gain factor. The proportional gain value is a multiplier on the controller error (difference between measured value and setpoint value.) Increasing this value will make the controller more responsive.

PID Int

[Iout1=PID]

Integral is the number of “repeats-per-minute” of the action of the controller. It is the number of times per minute that the controller acts on the input error. At a setting of 2.0 rpm, there are two repeats every minute. If the integral is set to zero, a fixed offset value is added to the controller (manual reset.) Increasing this value will make the controller more responsive.

PID Deriv

[Iout1=PID]

Derivative is a second order implementation of Integral, used to suppress “second-order” effects from process variables. These variables may include items like pumps or mixers that may have minor impacts on the measured value. The derivative factor is rarely used in water treatment process, and therefore, it is best in most cases to leave it at the default value. Increasing this value will make the controller more responsive.

Set 4 mA #2**Set 20 mA #2**[temp/KMnO₄]

These functions set the second 4 mA and 20 mA current loop output points for the transmitter. The output may be set to track temperature (default) or KMnO₄. The values stored for the 4 mA point may be higher or lower than the value stored for the 20 mA point.

The entry value is limited to a value between 0 and 55 °C if it is set for temperature, within the range specified in “Set Range” if the output is set to track permanganate. The 4 mA and the 20 mA point must be at least 20 units away from each other. Press ENTER to initiate user entry mode, and the value will flash. Use arrow keys to modify value. Press ENTER to store the new value.

- A Setpoint** This function establishes the trip point for relay A. The entry value is limited to a value within the range specified in “Set Range”. Use the LEFT arrow key to select the first digit to be modified. Then use the UP and LEFT arrow keys to select the desired numerical value. Press ENTER to store the new value.
- A Hysteresis** This function establishes the hysteresis, or “deadband”, for Relay A. Hysteresis is most often used to control relay chattering; however, it may also be used in control schemes to separate the ON/OFF trip points of the relay. Press ENTER to initiate user entry mode, and the value will flash. Use the arrow keys to modify value. Press ENTER to store the new value.
- A Delay** This function places an additional amount of time delay on the trip point for relay A. This delay is in addition to the main delay setting for the controller. The entry value is limited to a value between 0 and 999 seconds. Press ENTER to initiate user entry mode, and the value will flash. Use arrow keys to modify value; range is 0 to 999 seconds. Press ENTER to store the new value.
- A Phasing** This function establishes the direction of the relay trip. When phase is HI, the relay operates in a direct mode. Therefore, the relay energizes and the LCD indicator illuminates when the permanganate value **exceeds** the setpoint. When the phase is LO, the relay energizes and the LCD indicator illuminates when the permanganate level drops **below** the setpoint. The failsafe setting does have an impact on this logic. The description here assumes the failsafe setting is OFF. Press ENTER to initiate user entry mode, and the entire value will flash. Use the UP arrow key to modify the desired value; selections include **HI** for direct operation or **LO** for reverse operation. Press ENTER to store the new value.

See Figure 19 below for a visual description of a typical control relay application.

When value rises to ≥ 1.000 ppm, relay closes.

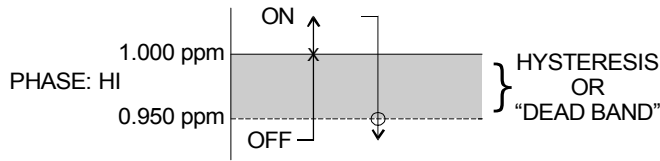

When value falls to ≤ 0.950 ppm, relay opens.

When value rises to ≥ 1.050 ppm, relay opens.

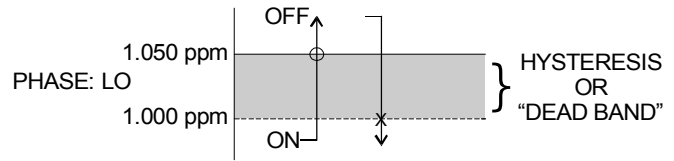

When value falls to ≤ 1.000 ppm, relay closes.

Settings:

Setpoint: 1.000 ppm
 Hyst: 0.050
 Delay: 000
 Failsafe: OFF

Figure 19 - Control Relay Example, Hysteresis & Two Phase Options

- *Setpnt A-HI
- *Hyst A-HI
- *Delay A-HI
- *Setpnt A-LO
- *Hyst A-LO
- *Delay A-LO

If Relay A Mode is set to Alarm Mode, **AL**, then the following settings will appear in the Config Menu list automatically. In this mode, two setpoints can be selected on the same relay, to create an alarm band. Phase HI selection causes the relay to energize outside of the band, and Phase LO causes the relay to energize inside of the band. This feature enables one relay to be used as a control relay while the other is used as a HI-LO Alarm relay at the same time. Setpoint A-LO must be set lower than Setpoint A-HI. When AL mode is first selected, Setpoint A-LO is defaulted to 0.

Figure 20 is a visual description of a typical alarm relay application.

When value rises to ≥ 1.000 ppm, relay closes, until value falls back to ≤ 0.950 ppm.

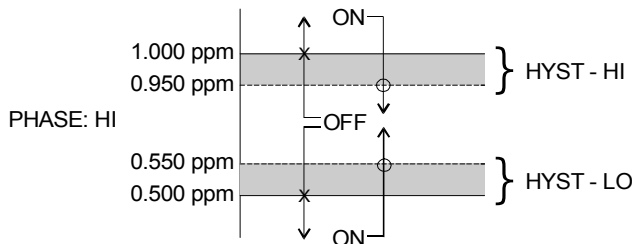

When value falls to ≤ 0.500 ppm, relay closes, until rises back to ≥ 0.550 ppm.

When value falls to ≤ 1.000 ppm, relay closes, until rises back to ≥ 1.050 ppm.

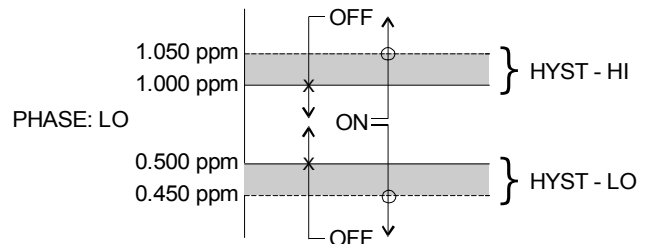

When value rises to ≥ 0.500 ppm, relay closes, until value falls back to ≤ 0.450 ppm.

Settings:

Setpoint	A-HI: 1.000 ppm	Setpoint	A-LO: .500 ppm
Hyst	A-HI: 0.050	Hyst	A-LO: .0.050
Delay	A-HI: 000	Delay	A-LO: 000

Figure 20 - Alarm Relay Example

***B Setpoint**
***B Hysteresis**
***B Delay**
***B Phasing**

If Relay B Mode is set to **CON** (see **Relay B Mode**, page 39), then Relay B will function identically to Relay A CON mode described earlier. Relay B settings appear in the CONFIG menu list automatically.

5.26 Diagnostics Menu [DIAG]

The diagnostics menu contains all of the user settings that are specific to the system diagnostic functions, as well as functions that aid in troubleshooting application problems.

Set Hold

The Set Hold function locks the current loop output values on the present process value, and halts operation of the PID controller. This function can be used prior to calibration, or when removing the sensor from the process, to hold the output in a known state. Once HOLD is released, the outputs return to their normal state of following the process input. The transfer out of HOLD is bumpless on both analog outputs - that is, the transfer occurs in a smooth manner rather than as an abrupt change. An icon on the display indicates the HOLD state, and the HOLD state is retained even if power is cycled. Press ENTER to initiate user entry mode, and entire value will flash. Use the UP arrow key to modify the desired value, selections are **ON** for engaging the HOLD function, and **OFF** to disengage the function. Press ENTER to store the new value.

Note: The Set Hold function holds BOTH current levels, as well as ALL relay settings.

The Set Hold function can also hold at an output value specified by the user. To customize the hold value, first turn the HOLD function on. Press the ESC key to go to the DIAG Menu and scroll to Sim Output using the UP arrow key. Press ENTER. Follow the instructions under Sim Output (see following page).

Fault List

The Fault List screen is a read-only screen that allows the user to display the cause of the highest priority failure. The screen indicates the number of faults present in the system and a message detailing the highest priority fault present. Note that some faults can result in multiple displayed failures due to the high number of internal tests occurring. As faults are corrected, they are immediately cleared.

Faults are not stored; therefore, they are immediately removed if power is cycled. If the problem causing the faults still exists, however, faults will be displayed again after power is re-applied and a period of time elapses during which the diagnostic system re-detects them. The exception to this rule is the calibration failure. When a calibration fails, no corrupt data is stored. Therefore, the system continues to function normally on the data that was present before the calibration was attempted.

After 30 minutes or if power to the transmitter is cycled, the failure for calibration will be cleared until calibration is attempted again. If the problem still exists, the calibration failure will re-occur. Press ENTER to initiate view of the highest priority failure. The display will automatically return to normal after a few seconds.

Sim Out

The Sim Out function allows the user to simulate the permanganate level in the user selected display range. The user enters a ppm value directly onto the screen, and the output responds as if it were actually receiving the signal from the sensor. This allows the user to check the function of attached monitoring equipment during set-up or troubleshooting. Escaping this screen returns the unit to normal operation. Press ENTER to initiate the user entry mode, and the right-most digit of the value will flash. Use arrow keys to modify desired value.

PID Timer

This function sets a timer to monitor the amount of time the PID controller remains at 0% or 100%. This function only appears if the PID controller is enabled. If the timer is set to 0000, the feature is effectively disabled. If the timer value is set to any number other zero, a FAIL condition will occur if the PID controller remains at 0% or 100% for the timer value. If one of the relays is set to FAIL mode, this failure condition can be signaled by a changing relay contact.

Press ENTER to initiate user entry mode, and the entire value will flash. Use the UP arrow key to modify desired value; range of value is 0-9999 seconds. Press ENTER to store the new value.

The starting display value will be the last read value of the input. The output will be under control of the SIM screen until the ESC key is pressed.

Note: If the HOLD function is engaged before the Sim Output function is engaged, the simulated output will remain the same even when the ESC key is pressed. Disengage the HOLD function to return to normal output.

Fail Out # 1

This function enables the user to define a specified value that the main current output will go to under fault conditions. When the Relay Option Board is installed, the display will read **Fail Out #1**. When enabled to **ON**, the output may be forced to the current value set in **Fail Val** (next item.) With the Fail Out setting of ON, and a Fail Val setting of 6.5 mA, any alarm condition will cause the current loop output to drop outside the normal operating range to exactly 6.5 mA, indicating a system failure that requires attention.

Press ENTER to initiate user entry mode, and the entire value will flash. Use the UP arrow key to modify desired value; selections are **ON**, **OFF**. Press ENTER to store the new value.

Fail Val # 1

Sets the output failure value for lout#1. When **Fail Out** above is set to **ON**, this function sets value of the current loop under a FAIL condition. When the Relay Option Board is installed, the display will read **Fail Out #1**. The output may be forced to any current value between 4-20 mA.

Press ENTER to initiate user entry mode, and the entire value will flash. Use the UP arrow key to modify desired value; selections are between **4mA**, and **20mA**. Press ENTER to store the new value.

Fail Out #2 This function sets the fail-mode of current loop output #2 under a FAIL condition. The settings and operation are identical to Fail Out for output #1.

Fail Val #2 This function sets the value of current loop output #2 under a FAIL condition. The settings and operation are identical to Fail Out for output #1.

Failsafe This function allows the user to set the optional system relays to a failsafe condition. In a failsafe condition, the relay logic is reversed so that the relay is electrically energized in a normal operating state. By doing this, the relay will not only change state when, for example, a concentration limit is exceeded, but also when power is lost to the controller.

When failsafe is selected to be ON, the normally-open contacts of the relay will be closed during normal operation. In an attempt to make this configuration less confusing, the LCD icon logic is reversed with this setting, and the icon is OFF under this normal condition. Therefore, when the trip condition occurs, the closed N.O. contacts will be opened (relay de-energized), and the LCD icon will illuminate. In addition, a power fail would also cause the same contacts to open.

Set Default The Set Default function allows the user to return the instrument back to factory default data for all user settings or for just the calibration default. It is intended to be used as a last resort troubleshooting procedure. All user settings or the calibration settings are returned to the original factory values. Hidden factory calibration data remains unchanged. Press ENTER to initiate user entry mode and select either **CAL** or **ALL** with the UP arrow key. The default CAL routine will reset the zero offset to 0.0 nA and reset the slope to 100%. The default ALL routine will reset all program variables to factory default and should be used with care since it will change any user settings that were programmed in the field.

Part 6 – Calibration

6.1 Chemistry System Startup

Prior to operating the chemistry module, connect inlet sample and drain tubing to the hose barbs provided on inlet overflow assembly. Recheck to be sure that the sample pickup tube from the sample pump and the drain tube from the stripping chamber are inserted into the proper chambers of the overflow assembly. The sample pickup tube must be completely submerged in the inlet chamber.

A 3-way valve on the inlet to the sample pump is supplied so that distilled water or a captured sample can be fed into the unit through a separate sample line. A 1/8" I.D. hose barb on the front of the valve is provided for connection of a pickup tube for distilled water or other sample. A length of silicon tubing is supplied for this purpose.

Once sample and drain connections are made, carefully turn on the sample flow so that sample is overflowing into the drain chamber. The rate of sample flow is not critical. However, the flow must not be so high that the drain cannot carry the excess away without overflowing the entire assembly. The drain chamber should remain almost empty during normal operation, with sample flowing freely out of the drain.

Once the sensor is in place, the sample pump pickup tube is located properly, and the reagent bottles are connected to the reagent pump, plug the AC power cord into any AC outlet. The two peristaltic pumps on the bottom of the module will start to turn and the rotameter on the panel should begin to indicate the air flow rate going to the bottom of the reactor. Use the air flow control valve to adjust the rotameter to 400 cc. per minute. Note that this air flow adjustment should not be made until sample has entered the stripping chamber. Observe the drain tubing and adjust the air flow after you see water draining from the reactor.

It is recommended that you start up the system with a bottle of distilled water connected to the second inlet port as mentioned above. Connect tubing to the 1/8" barb fitting and turn the 3-way valve so that the handle is down. This will close off the normal inlet and open the alternate inlet so that distilled water can be pumped into the system. The monitor needs to be zeroed initially, so it is best to start the system with water containing no permanganate.

The system will take some time to get sample into the reactor chamber and to begin to deliver reagents into the system. It is best to allow the system to run undisturbed for 30 – 60 minutes after initial startup. Note that the electronics module should also be powered up at this time. The sensor will not stabilize unless the power to the monitor is turned on. After about 2 minutes of operation, you should see an occasional small air bubble in the vertical tube section right after the “T” fitting where reagent is injected. This indicates that the reagent pump is running but reagent has not yet reached the mixing tee. When reagents have been drawn up through the delivery tube, these bubbles will stop, indicating that reagents are now being mixed.

After the chemistry module has been running for 60 minutes on distilled water, the sensor should be stable at zero. The LCD display on the electronic module may not be reading exactly zero, but the value should normally be less than 0.1 PPM and the value should be stable. If the system is not yet completely stable, the value may be decreasing very slowly. Wait to zero and calibrate the unit until the value stabilizes. Note that the zero value may vary by ± 0.005 PPM (5 PPB) both up and down once it reaches stability. This is the normal zero stability. At this point, the system is ready for zeroing and calibration as described in the operating section. However, you may want to first go through the configuration of the electronics to set the analog output range and configure any alarms you may wish to use. The next section covers the various configuration settings.

6.2 Permanganate Calibration

After power is applied, the sensor must be given time to stabilize. This is best done by operating the monitor on distilled water as described above. The sample to be monitored can be connected to the inlet overflow and the sample allowed to flow during this time.

6.11 Permanganate Zero Cal

In order to properly zero a permanganate system, it is necessary to run permanganate free water through the system for 15-30 minutes. **This should be done only after the monitor has been running for at least 1 hour to allow complete stabilization.**

The steps below assume that the sensor has been prepared in accordance with section 4.2, Sensor Assembly, earlier in this manual. It also assumes that the system has been running for 1 hour prior to attempting to zero the unit. If the stabilization procedure described in Section 6.1 was followed, the unit will be ready to zero after running distilled water for an hour. Proceed as follows:

1. With distilled water being fed through the alternate inlet port of the 3-way valve, observe the reading on the LCD display. The reading should be stable at a value less than 0.2 PPM KMnO_4 .
2. Scroll to the CAL menu section using the MENU key and press ENTER or the UP arrow key. **Cal KMnO_4** will then be displayed.
3. Press the ENTER key. The screen will display a flashing **1-Ref** for span calibration or a **2-Zer** for zero calibration. Using the UP arrow key, set for a **2-Zer** zero calibration and press ENTER.
4. The system now begins acquiring data for the sensor zero calibration value. As data is gathered, the units for sensor current in nanoamps (nA) and temperature may flash. Flashing units indicate that this parameter is unstable. The calibration data point acquisition will stop only when the data remains stable for a pre-determined amount of time. This can be overridden by pressing ENTER. If the data remains unstable for 10 minutes, the calibration will fail and the message **Cal Unstable** will be displayed.
5. If accepted, the screen will display the message **PASS** with the new sensor zero reading (offset), then it will return to the main measurement display. If the calibration fails, a message indicating the cause of the failure will be displayed and the FAIL icon will be turned on. The range of acceptable value for sensor offset is -25nA to +25 nA. Should a FAIL occur, carefully inspect the sensor for a tear in the membrane. It will probably be necessary to rebuild the sensor as described in section 4.2 Sensor Assembly. Should the offset value remain high and result in calibration failures, review the Service section of this manual, and then contact the service dept. at ATI for further assistance.

The sensor zero offset value in nA from the last zero calibration is displayed on the lower line of the Default Menus for information purposes.

6.12 Permanganate Span Cal

Span calibration of the system must be done against a laboratory measurement on the same sample that the sensor is measuring. A sample should be collected from the inlet line feeding the flow cell and quickly analyzed for permanganate using a test kit. When calibrating, it is best to have a reasonably high concentration of permanganate in the system. A value higher than 1.0 PPM is preferred to reduce the errors that might be introduced through errors in the test kit measurement at low concentrations.

Use the same sample inlet fitting and tube assembly for calibration that you used for the zero procedure. Collect a 1-liter sample containing permanganate treated water and use the test kit to determine the KMnO_4 level in a portion of this sample. Place the end of the inlet tube into this sample and let it run for 10 minutes. Then proceed as follows.

If the permanganate residual in the normal sample connected to the inlet assembly is sufficiently stable (should not vary by more than 0.05 PPM), then simply measure a sample from the inlet line and then let the analyzer run on normal sample. **Do not collect sample from the drain tube as this sample contains buffer and KI from the measured sample.**

It is possible to mix potassium permanganate standards for calibration if you have a high quality analytical balance and a supply of reagent grade potassium permanganate. Dissolve exactly 1 gram of KMnO_4 in 1 liter of distilled water. This will give you a solution very close to 750 mg/l as permanganate ion. Use this as a stock solution. It should be stable for about 1 week if stored in a dark, cool location.

Place 500 cc of distilled water in a container and add exactly 2 cc. of the permanganate stock solution. This will give you a 3 mg/l permanganate standard for use in calibration. Feed this solution into the inlet previously used for feeding distilled water. Continue to feed standard solution for 10 minutes.

Whatever method is used for delivering a known sample, proceed as follows to adjust the monitor.

1. Scroll to the CAL menu section using the MENU key and press ENTER or the UP arrow key. **Cal CL2** will then be displayed.
2. Press the ENTER key. The screen will display a flashing **1-Ref** for span calibration or a **2-Zer** for zero calibration. Using the UP arrow key, set for a **1-Ref** span calibration and press ENTER.
3. The system now begins acquiring data for the calibration value. As data is gathered, the units for ppm and temperature may flash. Flashing units indicate that this parameter is unstable. The calibration data point acquisition will stop only when the data remains stable for a pre-determined amount of time. This can be overridden by pressing ENTER. If the data remains unstable for 10 minutes, the calibration will fail and the message **Cal Unstable** will be displayed.
4. The screen will display the last measured ppm value and a message will be displayed prompting the user for the lab value. The user must then modify

the screen value with the arrow keys and press ENTER. The system then performs the proper checks.

5. If accepted, the screen will display the message **PASS** with the new sensor slope reading, then it will return to the main measurement display. If the calibration fails, a message indicating the cause of the failure will be displayed and the FAIL icon will be turned on. The range of acceptable values for sensor slope is 20% to 500%. It may be necessary to rebuild the sensor as described in section 5.4, Sensor Assembly. Should the slope value remain out of range and result in calibration failures, review the Service Section of this manual, then contact the service dept. at ATI for further assistance.
6. Turn the 3-way valve back to the normal operating position.

The sensor slope value in % from the last span calibration is displayed on the lower line of the Default Menu for information purposes.

6.2 Temperature Calibration

The temperature calibration sequence is essentially a 1-point offset calibration that allows adjustments of approximately ± 5 °C.

The sensor temperature may be calibrated on line, or the sensor can be removed from the process and placed into a known solution temperature reference. In any case, it is critical that the sensor be allowed to reach temperature equilibrium with the solution in order to provide the highest accuracy. When moving the sensor between widely different temperature conditions, it may be necessary to allow the sensor to stabilize as much as one hour before the calibration sequence is initiated. If the sensor is on-line, the user may want to set the output HOLD feature prior to calibration to lock out any output fluctuations.

1. Scroll to the CAL menu section using the MENU key and press ENTER or the UP arrow key.
2. Press the UP arrow key until **Cal Temp** is displayed.
3. Press the ENTER key. The message **Place sensor in solution then press ENTER** will be displayed. Move the sensor into the calibration reference (if it hasn't been moved already) and wait for temperature equilibrium to be achieved. Press ENTER to begin the calibration sequence.
4. The calibration data gathering process will begin. The message **Wait** will flash as data is accumulated and analyzed. The °C or °F symbol may flash periodically if the reading is too unstable.
5. The message **Adjust value - press ENTER** will be displayed, and the right-most digit will begin to flash, indicating that the value can be modified. Using the UP and LEFT arrow keys, modify the value to the known ref solution temperature. Adjustments up to ± 5 °C from the factory calibrated temperature are allowed. Press ENTER.

Once completed, the display will indicate **PASS** or **FAIL**. If the unit fails, the temperature adjustment may be out of range, the sensor may not have achieved complete temperature equilibrium, or there may be a problem with the temperature element. In the event of calibration failure, it is recommended to attempt the calibration again immediately.

Part 7 – PID Controller

7.1 PID Description

PID control, like many other control schemes, are used in chemical control to improve the efficiency of chemical addition or control. By properly tuning the control loop that controls chemical addition, only the amount of chemical that is truly required is added to the system, saving money. The savings can be substantial when compared to a system which may be simply adding chemical at a constant rate to maintain some minimal addition under even the worst case conditions. The PID output controller is highly advantageous over simple control schemes that just utilize direct (proportional only) 4-20 mA output connections for control, since the PID controller can automatically adjust the “rate” of recovery based on the error between the setpoint and the measured value – which can be a substantial efficiency improvement..

The PID controller is basically designed to provide a “servo” action on the 4-20 mA output to control a process. If the user requires that a measured process stay as close as possible to a specific setpoint value, the controller output will change from 0% to 100% in an effort to keep the process at the setpoint. To affect this control, the controller must be used with properly selected control elements (valves, proper chemicals, etc.) that enable the controller to add or subtract chemical rapidly enough. This is not only specific to pumps and valves, but also to line sizes, delays in the system, etc.

This section is included to give a brief description of tuning details for the PID controller, and is not intended to be an exhaustive analysis of the complexities of PID loop tuning. Numerous sources are available for specialized methods of tuning that are appropriate for a specific application.

7.2 PID Algorithm

As most users of PID controllers realize, the terminology for the actual algorithm terms and even the algorithms themselves can vary between different manufacturers. This is important to recognize as early as possible, since just plugging in similar values from one controller into another can result in dramatically different results. There are various basic forms of PID algorithms that are commonly seen, and the implementation here is the most common version; The ISA algorithm (commonly referred to as the “ideal” algorithm.)

$$\text{output} = P \left[e(t) + \frac{1}{I} \int e(t) dt + D \frac{de(t)}{dt} \right]$$

Where:

output =	controller output
P =	proportional gain
I =	integral gain
D =	derivative gain
t =	time
e(t) =	controller error (e=measured variable – setpoint)

Figure 21 - Q45 ISA PID Equation

The most notable feature of the algorithm is the fact the proportional gain term affects all components directly (unlike some other algorithms - like the “series” form.) If a pre-existing controller utilizes the same form of the algorithm shown above, it is likely similar settings can for made if the units on the settings are exactly the same. Be careful of this, as many times the units are the reciprocals of each other (i.e. reps-per-min, sec-per-rep.)

PID stands for “proportional, integral, derivative.” These terms describe the three elements of the complete controller action, and each contributes a specific reaction in the control process. The PID controller is designed to be used in a “closed-loop” control scheme, where the output of the controller directly affects the input through some control device, such as a pump, valve, etc.

Although the three components of the PID are described in the setting area (section 6.25), here are more general descriptions of what each of the PID elements contribute to the overall action of the controller.

- P** Proportional gain. With no “I” or “D” contribution, the controller output is simply a factor of the proportional gain multiplied by the input error (difference between the measured input and the controller setpoint.) Because a typical chemical control loop cannot react instantaneously to a correction signal, proportional gain is typically not efficient by itself – it must be combined with some integral action to be useful. Set the P term to a number between 2-4 to start. Higher numbers will cause the controller action to be quicker.
- I** Integral gain. Integral gain is what allows the controller to eventually drive the input error to zero – providing accuracy to the control loop. It must be used to affect the accuracy in the servo action of the controller. Like proportional gain, increasing integral gain results in the control action happening quicker. Set the I term to a number between 3-5 to start (1-2 more than P). Like proportional gain, increasing the integral term will cause the controller action to be quicker.

- D Derivative gain. The addition of derivative control can be problematic in many applications, because it greatly contributes to oscillatory behavior. In inherently slow chemical control processes, differential control is generally added in very small amounts to suppress erratic actions in the process that are non-continuous, such as pumps and valves clicking on and off. However, as a starting point for chemical process control, its best to leave the “D” term set to 0.

Based on these descriptions, the focus on tuning for chemical applications really only involves adjustment of “P” and “I” in most cases. However, increasing both increases the response of the controller. The difference is in the time of recovery. Although combinations of high “P’s” and low “I” will appear to operate the same as combinations of low “P’s” and high “I’s”, there will be a difference in rate of recovery and stability. Because of the way the algorithm is structured, large “P’s” can have a larger impact to instability, because the proportional gain term impacts all the other terms directly. Therefore, keep proportional gain lower to start and increase integral gain to achieve the effect required.

Many of the classical tuning techniques have the user start with all values at 0, and then increase the P term until oscillations occur. The P value is then reduced to $\frac{1}{2}$ of the oscillatory value, and the I term is increased to give the desired response. This can be done with the Q45H controller, with the exception that the I term should start no lower than 1.0.

If it appears that even large amounts of integral gain (>20) don’t appreciably increase the desired response, drop I back to about 1.0, and increase P by 1.00, and start increasing I again. In most chemical control schemes, I will be approximately 3 times the value of P.

7.3 Classical PID Tuning

Unlike many high speed position applications where PID loops are commonly used, the chemical feed application employed by this instrument does not require intense mathematical exercise to determine tuning parameters for the PID. In fact, the risk of instability is far greater with overly tuned PID control schemes. In addition, many of the classical mathematical exercises can be damaging or wasteful in the use of chemicals when the process is bumped with large amounts of input error to seek a response curve. Because of this, the general adjustment guidelines described in section 8.2 are sufficient for almost all application tuning for this instrument. Beyond this, many sources are available for classical tuning methods.

7.4 Manual PID Override Control

The Q45 PID output function allows the user to take manual control of the PID control signal. This is often useful when starting up a control loop, or in the event that you wish to bump the system manually to measure system response time.

To access the manual PID control, you must be in the MEASURE mode of operation and you must have the PID output displayed on the lower line. This line will indicate “XX.X% XX.X mA” with the X values simply indicating the current values. With this display on the screen, press and hold the ENTER key for about 5 seconds. You will see a small “m” show up between the % value and the mA value. This indicates you are now in manual mode.

Once in manual, you may increase the PID output by pressing the UP arrow or you may decrease the output by pressing the LEFT arrow. This will allow you to drive the PID output to any desired setting.

To revert to normal PID control, press and hold the ENTER key again until the “m” indicator disappears.

7.5 Common PID Pitfalls

The most common problem occurring in PID control applications involves the false belief that proper settings on only the PID controller can balance any process to an efficient level.

Close-loop control can only be effective if all elements in the loop are properly selected for the application, and the process behavior is properly understood. Luckily, the nature of simple chemical control processes is generally slow. Therefore, even a de-tuned controller (one that responds somewhat slowly) can still provide substantial improvements to setpoint control. In fact, damaging oscillatory behavior is far more likely in tightly tuned controllers where the user attempted to increase response too much.

When deciding on a PID control scheme, it is important to initially review all elements of the process. Sticking valves, undersized pumps, or delays in reaction times associated with chemical addition can have a dramatic effect on the stability of the control loop. When controlling a chemical mix or reaction, the sensor should be placed in a location that ensures proper mixing or reaction time has occurred.

The easiest processes to control with closed-loop schemes are generally linear, and symmetrical, in nature. For example, controlling level in tank where the opening of valve for a fixed period of time corresponds linearly to the amount that flows into a tank. Chemical control processes can be more problematic when the nature of the setpoint value is non-linear relative to the input of chemical added. For example, pH control of a process may appear linear only in a certain range of operation, and become highly exponential at the extreme ranges of the measuring scale. In addition, if a chemical process is not symmetrical, that means it responds differentially to the addition and subtraction of chemical. It is important in these applications to study steady-state impact as well as step-change impact to process changes. In other words, once the process has apparently been tuned under normal operating conditions, the user should attempt to force a dramatic change to the input to study how the output reacts. If this is difficult to do with the actual process input (the recommended method), the user can place the control in manual at an extreme control point such as 5% or 95%, and release it in manual. The recovery should not be overly oscillatory. If so, the loop needs to be de-tuned to deal with that condition (reduce P and/or I.)

Part 8 – System Maintenance

8.1 General

The Q45/83 Permanganate System will generally provide unattended operation over long periods of time. With proper care, the system should continue to provide measurements indefinitely. For reliable operation, maintenance on the system must be done on a regular schedule. Keep in mind that preventive maintenance on a regular schedule is much less troublesome than emergency maintenance that always seems to come at the wrong time.

8.2 Analyzer Maintenance

No unusual maintenance of the analyzer is required if installed according to the guidelines of this operating manual. If the enclosure door is frequently opened and closed, it would be wise to periodically inspect the enclosure sealing gasket for breaks or tears.

8.3 Sensor Maintenance

Sensor maintenance is required for accurate measurements. The primary requirement is simply to keep the sensor membrane clean. The membrane is a micro-porous polymer that is resistant to anything that will be encountered in water streams. However, deposits can form on the surface or in the pores of the membrane, and these deposits will reduce the sensitivity. Certain constituents in water, mainly iron and manganese, will precipitate when the water is chlorinated. These precipitates can sometimes form a coating on the membrane.

Because membranes are micro-porous, they can be relatively difficult to clean effectively. Immersing the tip of the sensor in 1N nitric acid solution will sometimes remove deposits that cause low sensitivity, but this is not always the case. The recommended practice is to simply replace the membrane when it becomes fouled. To change a membrane, follow the Sensor Assembly procedure on page 27 of this manual. Do not reuse the electrolyte from the sensor when changing a membrane. Always refill with fresh electrolyte. The electrolyte is stable and does not have a limited shelf life.

Refer again to the explanation of the sensor slope number after an accepted span calibration on the lower MEASURE screen. In normal operation, the slope of the sensor output will decrease over time as the membrane becomes fouled. This reduction indicates that the sensor is losing sensitivity to permanganate. It is good practice to replace the membrane if the slope number falls to 30-40%. The value will not go below 20%.

Even if no buildup is apparent on the membrane, it should be changed on a regular schedule. The recommended membrane change interval is every 3 months. For high purity water applications, this can probably be extended if desired, but a more frequent changing interval is a small price to pay for avoiding membrane failure at the wrong time.

While the sensor is disassembled for membrane changing, examine the condition of the o-rings on both ends of the electrolyte chamber. If the o-rings show any signs of damage, replace them with new ones from the spare parts kit. It is good practice to change these o-rings once a year, regardless of their condition.

8.31 Sensor Acid Cleaning

Over an extended operating period, sensors can slowly accumulate deposits on the surface of the measuring electrode. Typically, this type of buildup occurs over years of operation, but can sometimes occur more quickly in high levels of manganese, iron, or other metals are dissolved in the water. The measuring electrode can be “acid cleaned” using nitric acid solutions.

WARNING

THIS ACID CLEANING PROCEDURE INVOLVES THE USE OF HIGHLY CORROSIVE ACID SOLUTIONS. IT SHOULD ONLY BE COMPLETED BY TRAINED PERSONNEL USING PROTECTIVE EYEWEAR AND GLOVES. IF THERE IS ANY DOUBT ABOUT YOUR ABILITY TO SAFELY ACCOMPLISH THIS PROCEDURE, RETURN THE SENSOR TO ATI FOR FACTORY CLEANING!

To acid clean the electrode assembly, remove the electrolyte chamber from the sensor so that the so that the electrodes are exposed. Then follow the procedure below.

1. Place a small amount of 50% nitric acid solution in a beaker. Put in just enough so that the tip of the sensor can be submerged without any contact with the small electrode coil just above the tip.
2. Allow the sensor to soak in this acid solution for 2 minutes. Remove the sensor body and rinse the tip thoroughly with distilled water. Discard the nitric acid safely and according to all environmental regulations.

3. Fill the beaker with distilled water to the level sufficient to submerge both the entire electrode assembly. Do not allow the connector at the back of the sensor to be submerged. Allow the electrodes to soak in distilled water for 30 minutes.
4. Put a new membrane and fresh electrolyte in the electrolyte chamber and reassemble the sensor. Connect to the permanganate monitor electronics and allow the sensor to stabilize for at least 24 hours. The sensor can be placed in the flow cell with sample water running through it during stabilization. However, the readings will not be useful for 12-24 hours after an acid cleaning.

8.4 Stripping Chamber Maintenance

The maintenance on the stripping chamber is simple cleaning. The chamber is a white Teflon part used because iodine does not easily adhere to the surface. However, measurement of potassium permanganate results in the buildup of manganese inside the air stripping chamber. If not cleaned periodically, this can present operating problems after many months of use.

Removing the buildup of manganese inside the stripping chamber is relatively simple using a special chemical solution. One of the spare parts included with the analyzer is a container of "Red-B-Gone". This chemical is used to remove iron and manganese buildup on surfaces.

Pour 250 cc (8 oz.) of distilled water into a container and add 2 teaspoons of Red-B-Gone. Mix thoroughly to dissolve the chemical. Using the alternate inlet port normally used for feeding zero water or standard, feed this solution through the analyzer until all of it has been fed through the system. You may leave the sensor in place while feeding the cleaning chemical.

Cleaning of the stripping chamber with Red-B-Gone should be done every 2 months.

Change the o-ring in the sensor chamber yearly or if any damage is observed. If insertion of the sensor into the flow cell becomes difficult, use silicon grease to lubricate the o-ring that holds the sensor in place. Use only enough grease to provide surface lubrication. Excess grease could foul the sensor membrane.

8.5 Peristaltic Pump Service

Peristaltic pump tubing MUST be changed every 6 months. One set of replacement tubing is supplied with the unit and additional tube sets are available in packages of 5 for sample tube and 10 for reagent tube (see spare parts list). If tubing wear or leakage is noted in less than 6 months, tubing should also be replaced immediately. It is unlikely that reagent feed tubing will require more frequent replacement, but grit in the incoming sample can cause wear on the sample tubing, shortening the replacement interval.

Prior to replacing reagent tubing, disconnect the reagent pickup lines from the connectors at the inlet of the two pump tubes. Allow the system to run for 15 minutes to purge the inside the tubing with the clean water. Allow the pump to run for 2-3 minutes to pump out the entire sample.

Replacement of pump tubing is very simple with the quick loading pump heads used in this system. Follow the procedure below for both the sample and reagent pump heads. Turn off power to the chemistry module prior to replacing pump tubes.

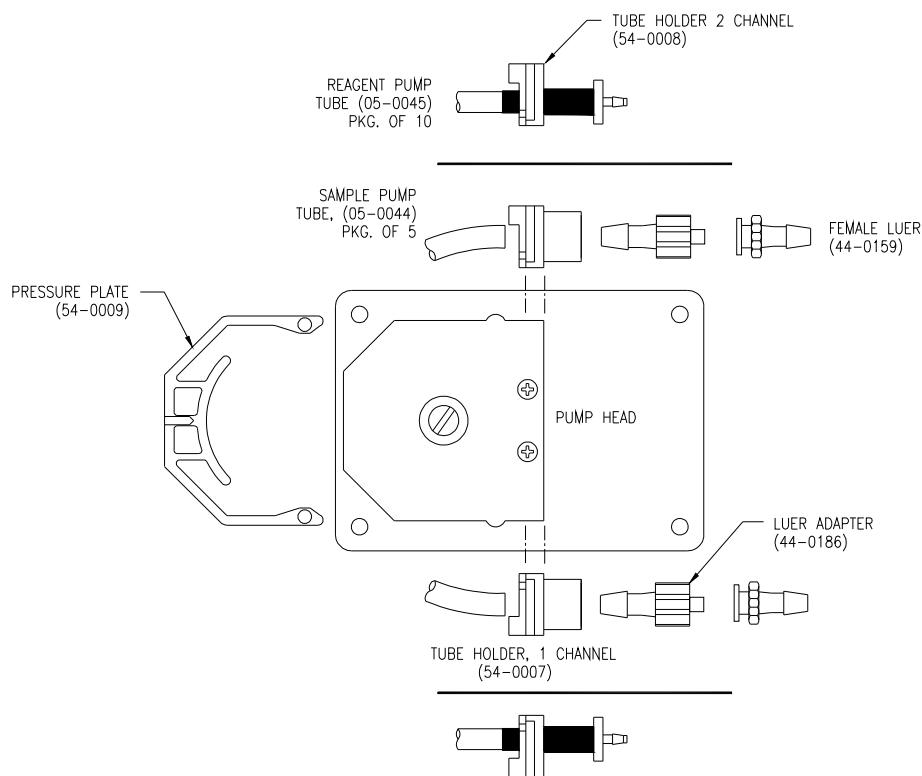

Figure 22 - Pumhead Assembly Exploded View

Part 9 – Troubleshooting

9.1 General

The information included in this section is intended to be used in an attempt to quickly resolve an operational problem with the system. During any troubleshooting process, it will save the most time if the operator can first determine if the problem is related to the analyzer, sensor, or some external source. Therefore, this section is organized from the approach of excluding any likely external sources, isolating the analyzer, and finally isolating the sensor. If these procedures still do not resolve the operational problems, any results the operator may have noted here will be very helpful when discussing the problem with the factory technical support group.

9.2 External Sources of Problems

To begin this process, review the connections of the system to all external connections.

1. Verify the analyzer is earth grounded. For all configurations of the analyzer, an earth ground connection **MUST** be present for the shielding systems in the electronics to be active. Grounded conduit provides no earth connection to the plastic enclosure, so an earth ground wiring connection must be made at the power input terminal strip. Verify metal shield is present over incoming power connections. This shield is for safety purposes, but also blocks electrical spikes from relay and power wiring.
2. Verify the proper power input is present (115/230 VAC or 16-35 VDC).
3. Verify the loads on any 4-20 mA outputs do not exceed the limits in the Instrument Specifications. During troubleshooting, it is many times helpful to disconnect all these outputs and place wire-shorts across the terminals in the instrument to isolate the system and evaluate any problems which may be coming down the analog output connections.
4. Do not run sensor cables or analog output wiring in the same conduits as power wiring. If low voltage signal cables must come near power wiring, cross them at 90° to minimize coupling.

5. If rigid conduit has been run directly to the Q45 enclosure, check for signs that moisture has followed conduit into the enclosure.
6. Check for ground loops. Although the membrane sensor is electrically isolated from the process water, high frequency sources of electrical noise may still cause erratic behavior in extreme conditions. If readings are very erratic after wiring has been checked, check for a possible AC ground loop by temporarily disconnecting feed and drain lines from the filter assembly. The reading should stabilize.
7. On relay based systems, check the load that is connected to the relay contacts. Verify the load is within the contact rating of the relays. Relay contacts which have been used for higher power AC current loads may become unsuitable for very low signal DC loads later on because a small amount of pitting can form on the contacts. If the load is highly inductive (solenoids, motor starters, large aux relays), note that the contact rating will be de-rated to a lower level. Also, due to the large amount of energy present in circuits driving these types of loads when they are switched on an off, the relay wiring placement can result in electrical interference for other devices. This can be quickly resolved by moving wiring, or by adding very inexpensive snubbers (such As Quencharcs) to the load.
8. Carefully examine any junction box connections for loose wiring or bad wire stripping. If possible, connect the sensor directly to the analyzer for testing.
9. Check sensor membrane for fouling. Look closely for signs of grease or oil which may be present. Replace membrane and electrolyte, allow to stabilize, and re-check. The procedure in Sensor Assembly, on page 27, must be followed when replacing the membrane.

9.3 Analyzer Tests

1. Disconnect power and completely disconnect all output wiring coming from the analyzer. Remove sensor wiring, relay wiring, and analog output wiring. Re-apply power to the analyzer.
2. Using the Simulate feature, check operation of analog outputs and relays with a DMM.
3. Check cell drive circuit. With a digital voltmeter (DVM), measure the voltage between the ORANGE and WHITE terminals on the back of the monitor to verify that the millivolt value is actually -400 mV.

4. Check TC drive circuit. Place a wire-short between the GREEN and BLACK terminals. With a digital voltmeter (DVM), measure the voltage between the BLACK and RED terminals on the back of the monitor to verify that the TC drive circuit is producing about 4.8-5.1 VDC open circuit. Remove DVM completely and connect a 100 Ohm resistor from the BLACK to RED terminals. The temperature reading should display approximately 0°C and the permanganate reading should display approximately 0 ppm.

9.4 Chemistry System Tests

Problems with the permanganate monitor are most likely to originate with the sample inlet filter, the sample and reagent pumps, or the sensor. If problems arise, the first thing to do is verify certain basic chemistry system functions.

1. Check the inlet tubing for any kind of blockage. Check to see that the sample pump outlet flow rate is approximately correct. The pump should deliver sample at about 5-6 cc/min. If the sample pickup is not functioning, check the tube on the sample pump and replace if necessary.
2. Check that the two reagent pumps are delivering reagent to the chemical injection fittings. To do this, disconnect the sample inlet so that the sample pump is only pulling in air. Also, **turn off the inlet flow to the filter assembly to avoid water backfeeding through the drain line when tubes are disconnected.** Stop the pumps temporarily by turning off power to the chemistry module. Disconnect the reagent outlet tubes from the two injection tees and then turn pump power back on. The pump delivers reagent at a rate of 0.05 cc/min. You should see a small drop of reagent slowly form at the outlet of each tube. If no reagent is being delivered, replace the reagent pump tubes on the peristaltic pump. These tubes should be replaced every 6 months.
3. Check the sensor for membrane fouling. Turn the pumps off and unplug the sensor cable. Remove the sensor from the flowcell (hold a small sponge or paper towel under the flowcell when removing the sensor to catch the small amount of sample that will spill out).

If all of these chemistry systems components are functioning properly, the permanganate monitor should produce valid readings and any problems are likely to be associated with the electronic monitor or the interconnecting cable.

9.5 Display Messages

The Q45 Series instruments provide a number of diagnostic messages which indicate problems during normal operation and calibration. These messages appear as prompts on the secondary line of the display or as items on the Fault List.

MESSAGE	DESCRIPTION	POSSIBLE CORRECTION
Max is 200	Entry failed, maximum user value allowed is 200.	Reduce value to ≤ 200
Min is 200	Entry failed, minimum value allowed is 200.	Increase value to ≥ 200
Cal Unstable	Calibration problem, data too unstable to calibrate. Icons will not stop flashing if data is too unstable. User can bypass by pressing ENTER.	Clean sensor, get fresh cal solutions, allow temperature and conductivity readings to fully stabilize, do not handle sensor or cable during calibration.
Out of Range	Input value is outside selected range of the specific list item being configured.	Check manual for limits of the function to be configured.
Locked!	Transmitter security setting is locked.	Enter security code to allow modifications to settings.
Unlocked!	Transmitter security has just been unlocked.	Displayed just after security code has been entered.
Offset High	The sensor zero offset point is out of the acceptable range of -20 to +20 nA.	Check wiring connections to sensor. Allow sensor to operate powered a minimum of 12 hours prior to first zero cal.
Sensor High	The raw signal from the sensor is too high and out of instrument range.	Check wiring connections to sensor.
Sensor Low	The raw signal from the sensor is too low.	Check wiring connections to sensor.
KMnO2 High	The permanganate reading is greater than the maximum of the User-selected range.	The permanganate reading is over operating limits. Set measuring range to the next highest level.
Temp High	The temperature reading is $> 55^{\circ}\text{C}$.	The temperature reading is over operating limits. Check wiring and expected temp level. Perform RTD test as described in sensor manual. Recalibrate sensor temperature element if necessary.
Temp Low	The temperature reading is $< -10^{\circ}\text{C}$	Same as "Temp High" above.
TC Error	TC may be open or shorted.	Check sensor wiring and perform RTD test as described in sensor manual. Check j-box connections.

Figure 23 - Q45 Display Messages

MESSAGE	DESCRIPTION	POSSIBLE CORRECTION
KMnO4 Cal Fail	Failure of calibration routine. FAIL icon will not extinguish until successful calibration has been performed, or 30 minutes passes with no keys being pressed.	Clean sensor redo zero and span calibration. If still failure, sensor slope may be less than 25% or greater than 250%. Perform sensor tests as described in section ?. Replace sensor if still failure.
TC Cal Fail	Failure of temperature calibration. FAIL icon will not extinguish until successful calibration has been performed, or 30 minutes passes with no keys being pressed.	Clean sensor, check cal solution temperature and repeat sensor temp calibration. TC calibration function only allows adjustments of +/- 6 °C. If still failure, perform sensor tests as described in section?. Replace sensor if still failure. .
EPROM Fail	Internal nonvolatile memory failure	System failure, consult factory.
Chcksum Fail	Internal software storage error.	System failure, consult factory.
Display Fail	Internal display driver fail.	System failure, consult factory.
Range Cal Fail	Failure of factory temperature calibration.	Consult factory.

9.6 Sensor Tests

1. Check the membrane condition. A membrane that is not stretched smoothly across the tip of the sensor will cause unstable measurements. If necessary, change membrane and electrolyte.
2. Permanganate sensors can be tested with a digital voltmeter (DVM) to determine if a major sensor problem exists. Follow the steps below to verify sensor integrity:
 - A. Disconnect the six sensor wires from the monitor. Those wires are color coded white, orange, blue, red, black, and green.
 - B. Remove the electrolyte chamber from the sensor and dry the electrodes with a paper towel.
 - C. Connect a DVM between the white and orange wires. Reading resistance, you should find an open circuit value of infinite resistance. There must be no measurable resistance at all between these wires. Any resistance at all indicates either water in the cable connector or the breakdown in an electrode seal.
 - D. Connect a DVM between the red and white wires. The red wire is part of the RTD circuit and the white wire is part of the measuring cell. There should be no connection. Reading resistance, you should find an open circuit value of infinite resistance. Any resistance at all indicates either water in the cable connector or the breakdown in an electrode seal.
 - E. Connect the DVM between the red and black wires. These are the RTD leads, and you should find a resistance value that depends on the temperature. The table below lists the resistance values for various temperatures. Reading resistance between the red and green wires should give exactly the same values as between red and black.

Temperature °C	Resistance Ω
0	100.0
5	101.9
10	103.9
15	105.8
20	107.8
25	109.7
30	111.7
35	113.6
40	115.5
45	117.5
50	119.4

Figure 24 - Pt100 RTD Table

If you suspect that water has gotten into a cable connection on a flow type sensor or into the plug connection of a submersible sensor, disconnect the cable and allow the parts of the sensor to sit in a warm place for 24 hours. If water in the connector is the problem, it should dry out sufficiently to allow normal sensor operation. However, steps 4 and 5 above will have to be repeated after drying to see if the problem is gone.

Spare Parts

<u>Part No.</u>	<u>Description</u>
07-0324	Complete permanganate monitor electronics, 120 VAC
07-0325	Complete permanganate monitor electronics, 230 VAC
00-0977	Gas phase Iodide sensor
03-0029	25 ft. Sensor cable
45-0090	Air Stripping chamber
03-0249	Air Stripping chamber cap w/o-ring
42-0024	Air Stripping chamber cap o-ring
42-0003	Sensor Chamber O-Ring
36-0009	Air pump
44-0119	Air Intake Filter (sold as each specify quantity)
55-0014	Rotameter with valve
03-0212	Sample Pump Assembly, 120 VAC
03-0213	Reagent Pump Assembly, 120 VAC
03-0234	Sample Pump Assembly, 220 VAC
03-0235	Reagent Pump Assembly, 220 VAC
05-0044	Sample pump tubing (pkg. of 5, precut)
05-0045	Reagent pump tubing (pkg. of 10)
05-0052	Sensor Membranes (10/pk)
09-0026	KMnO ₄ Electrolyte
09-0031	KI Reagent
05-0041	KMnO ₄ Accessories Kit
02-0081	Sensor Body
45-0149	Membrane Cap
45-0148	Sensor Electrolyte Chamber
31-0037	6 conductor cable (for interconnection of monitor to junction box)
23-0002	Fuse, 2 Amp Slow-Blow
03-0189	Reagent Feed Assembly
45-0153	3-Way Inlet Selector Valve
54-0007	Tube Holder – 1 channel (Sample Pump)
54-0008	Tube Holder – 2 channel (Reagent Pump)
44-0186	Luer Adapter
54-0009	Pressure Plate
44-0164	Male Luer Adapter
44-0114	Tube Connector
00-1340	Reagent Pickup Spare Filter Assy
00-1342	Reactor heater assembly
00-1343	Temperature Sensing Assembly, Pt100 RTD

Note: Instrument is supplied with sufficient spare parts for 6-12 months of operation. For 2 year spare parts inventory, 3 each of the items marked with an asterisk are required.

Lock/Unlock Code: 1456