

Model PQ45-84

Dissolved H₂O₂

Measurement

System

Home Office

Analytical Technology, Inc.
6 Iron Bridge Drive
Collegeville, PA 19426

Ph: 800-959-0299
610-917-0991

Fax: 610-917-0992

Email: sales@analyticaltechnology.com

European Office

ATI (UK) Limited
Unit 1 & 2 Gatehead Business Park
Delph New Road, Delph
Saddleworth OL3 5DE

Ph: +44 (0)1457-873-318

Fax: + 44 (0)1457-874-468

Email: sales@atiuk.com

PRODUCT WARRANTY

Analytical Technology, Inc. (Manufacturer) warrants to the Customer that if any part(s) of the Manufacturer's equipment proves to be defective in materials or workmanship within the earlier of 18 months of the date of shipment or 12 months of the date of start-up, such defective parts will be repaired or replaced free of charge. Inspection and repairs to products thought to be defective within the warranty period will be completed at the Manufacturer's facilities in Collegeville, PA. Products on which warranty repairs are required shall be shipped freight prepaid to the Manufacturer. The product(s) will be returned freight prepaid and allowed if it is determined by the manufacturer that the part(s) failed due to defective materials or workmanship.

This warranty does not cover consumable items, batteries, or wear items subject to periodic replacement including lamps and fuses.

Gas sensors carry a 12 months from date of shipment warranty and are subject to inspection for evidence of misuse, abuse, alteration, improper storage, or extended exposure to excessive gas concentrations. Should inspection indicate that sensors have failed due to any of the above, the warranty shall not apply.

The Manufacturer assumes no liability for consequential damages of any kind, and the buyer by acceptance of this equipment will assume all liability for the consequences of its use or misuse by the Customer, his employees, or others. A defect within the meaning of this warranty is any part of any piece of a Manufacturer's product which shall, when such part is capable of being renewed, repaired, or replaced, operate to condemn such piece of equipment.

This warranty is in lieu of all other warranties (including without limiting the generality of the foregoing warranties of merchantability and fitness for a particular purpose), guarantees, obligations or liabilities expressed or implied by the Manufacturer or its representatives and by statute or rule of law.

This warranty is void if the Manufacturer's product(s) has been subject to misuse or abuse, or has not been operated or stored in accordance with instructions, or if the serial number has been removed.

Analytical Technology, Inc. makes no other warranty expressed or implied except as stated above.

Table of Contents

TABLE OF FIGURES.....	4	PART 6 – CALIBRATION.....	33
PART 1 - INTRODUCTION	2	6.1 Hydrogen Peroxide Calibration	33
1.1 General.....	2	6.11 H ₂ O ₂ Zero Cal	33
1.2 Standard System	2	6.12 H ₂ O ₂ Span Cal	34
1.3 Features.....	3	6.2 Temperature Calibration	36
1.4 Q45H/62 System Specifications	5	PART 7 – DATA LOGGER (OPTION)	37
1.5 Q45S Performance Specifications	6	7.1 General.....	37
PART 2 – SYSTEM COMPONENTS.....	7	7.2 Removing the Data Logger	37
2.1 General.....	7	7.3 Starting Logger	37
PART 3 – SENSOR PREPARATION	11	7.4 Logger Battery Replacement	38
3.1 Peroxide Sensor Preparation	11	PART 8 – SYSTEM MAINTENANCE.....	39
PART 4 – ELECTRICAL CONNECTIONS.....	13	8.1 General.....	39
4.1 General.....	13	8.2 Analyzer Battery Replacement	39
4.2 Sensor Connections.....	13	8.3 Peroxide Sensor Maintenance	39
4.3 Battery / Power Circuit Board.....	14	8.3.1 Sensor Acid Cleaning	40
4.4 External Power / Output Connections.....	15	8.4 Flow Cell Maintenance	41
PART 5 – OPERATION	17	PART 9 – TROUBLESHOOTING	42
5.1 User Interface.....	17	9.1 General.....	42
5.2 Battery Power Circuit Board.....	18	9.2 External Sources of Problems	42
5.3 Voltage Outputs	18	9.3 Analyzer Tests	43
5.4 External Power.....	19	9.4 Display Messages	44
5.5 Data logger Module	19	9.5 Sensor Tests	46
5.6 Maintaining Sensor Stability.....	19	SPARE PARTS	48
5.7 User Interface.....	20		
5.7.1 Keys	21		
5.7.2 Display.....	21		
5.8 Software	23		
5.8.1 Software Navigation	23		
5.8.2 Measure Menu [MEASURE].....	26		
5.8.3 Calibration Menu [CAL].....	27		
5.8.4 Configuration Menu [CONFIG]	27		
5.8.5 Control Menu [CONTROL]	29		
5.8.6 Diagnostics Menu [DIAG].....	30		

Table of Figures

<i>FIGURE 1 - PQ45 PORTABLE MONITOR SYSTEM.....</i>	<i>3</i>
<i>FIGURE 2 - FRONT VIEW OF HINGED PANEL.....</i>	<i>7</i>
<i>FIGURE 3 - SENSOR AND FLOW COMPONENTS.....</i>	<i>8</i>
<i>FIGURE 4 – PEROXIDE SENSOR ASSEMBLY.....</i>	<i>11</i>
<i>FIGURE 6 - SENSOR CONNECTIONS, PQ45 H₂O₂ SYSTEM.....</i>	<i>13</i>
<i>FIGURE 7 - BATTERY CIRCUIT BOARD W/C-CELL BATTERIES</i>	<i>14</i>
<i>FIGURE 8 - BATTERY CIRCUIT BOARD W/EXT. POWER TERMINALS</i>	<i>16</i>
<i>FIGURE 9 - EXT. CONNETION CABLE COLOR CODE</i>	<i>16</i>
<i>FIGURE 10 - BATTERY BOARD CONNECTION.....</i>	<i>18</i>
<i>FIGURE 11 - USER INTERFACE</i>	<i>20</i>
<i>FIGURE 12 - SOFTWARE MAP.....</i>	<i>25</i>
<i>FIGURE 16 - Q45H DISPLAY MESSAGES.....</i>	<i>44</i>
<i>FIGURE 17 - DISPLAY MESSAGES (CONTINUED)</i>	<i>45</i>
<i>FIGURE 18 - PT100 RTD TABLE</i>	<i>47</i>

Part 1 - Introduction

1.1 General

The Model PQ45-84 Portable H₂O₂ Monitor is designed for short-term measurement and data logging of Hydrogen Peroxide in water systems. It may also be used for permanent monitoring in locations where solar power systems are available to provide continuous power.

Each system is a self-contained package that includes a battery-powered or externally powered analyzer, sensor, flowcell assembly, and sample flow controls. Sample and drain connections are provided on the outside of the case, and connectors and tubing to adapt to water samples are supplied. Sample lines with pressures up to 75 PSI (5 Bar) may be connected without pressure reduction. For samples subject to higher pressures, a pressure-reducing valve should be used to control sample pressure to less than 75 PSI (5 Bar).

Both the fittings installed in the case and the fittings supplied for sample tubing connection externally are equipped with shut-off valves. When both fittings are plugged in, sample will flow. When either the inlet or outlet fittings are disconnected, sample flow will stop. Sample flow rate is controlled internally by a special orifice flow control device that provides a fixed 400 cc/min. flow at sample inlet pressures between 5 and 75 PSI (0.3-5.0 Bar). An in-line y-strainer is installed to trap particles larger than 65 micron.

Most system components are mounted on a hinged panel inside the case. The electronic unit is mounted on the front of the panel. If the optional data logger was ordered, this is also mounted on the front. Opening up the internal panel allows access to the sensor, flowcell, and flow control assembly. Maintenance items, connectors, and extra tubing are stored in the space behind the panel.

1.2 Standard System

Standard PQ45 systems include a battery-powered electronic unit, a peroxide sensor and flowcell, flow control components, sample and drain tubing, and various accessories. The standard batteries consist of two standard alkaline C-cell batteries located inside the electronic assembly.

Optional items may be installed if specified when ordered. The optional item for this parameter is a removable battery-powered data logger with software



Figure 1 - PQ45 Portable Monitor System

1.3 Features

- Standard main module is designed to be a fully isolated, battery-powered instrument. An optional arrangement provides for external power from a 10-16 VDC supply.
- High accuracy, high sensitivity system, measures from 0.1 ppm to 200.0 ppm through 4 internal automatic ranges. User ranges of 2.000 ppm, 20.00 ppm, or 200.0 ppm.
- Two 10-bit, isolated, 0-2.5 VDC analog outputs may be configured to track hydrogen peroxide and temperature. Both analog outputs can be individually programmed to specific ranges. Optional data logger (removable module) allows the user to gather up to 32000 total data.

- Large, high contrast, custom LCD display with LED back light provides excellent readability in any light conditions. The secondary line of display utilizes 5x7 dot matrix characters for clear message display. Two of four measured parameters may be on the display simultaneously.
- Diagnostic messages provide a clear description of any problem with no confusing error codes to look up. Messages are also included for diagnosing calibration problems.
- Quick and easy one-point calibration method and sensor zero-cal. To provide high accuracy, all calibration methods include stability monitors that check temperature and main parameter stability before accepting data.
- High accuracy three-wire Pt100 temperature input. Temperature element can be user calibrated.
- Security lock feature to prevent unauthorized tampering with transmitter settings. All settings can be viewed while locked, but they cannot be changed.
- Low battery indicator on the display alerts operators that the C-cell batteries are nearing end of life. Normal operational life for two C-cell batteries is about 30 days of continuous operation.

1.4 Q45H/62 System Specifications

Displayed Parameters	Main input, 0.001 ppm to 200.0 ppm Sensor temperature, -10.0 to 55.0 °C (23 to 131 °F) Sensor Current, 0.0–999.9 nA, 0.000 to 99.99 uA Output Voltage, 0-2.5 VDC Sensor slope/offset Model number and software version
Main Parameter Ranges	Manual selection of one of the following ranges, 0.0 to 2.000 ppm 0.00 to 20.00 ppm 0.00 to 200.0 ppm
Display	0.75" (19.1 mm) high 4-digit main display with sign 12-digit secondary display, 0.3" (7.6 mm) 5x7 dot matrix.
Keypad	4-key membrane type with tactile feedback, polycarbonate with UV coating
Weight	17 lbs. (7.3 Kg.)
Ambient Temperature	Analyzer Service, 0 to 60 °C (-4 to 140 °F) Sensor Service, 0 to 55°C (32 to 131 °F) Storage, 0 to 70 °C (32 to 158 °F)
Ambient Humidity	0 to 95%, non-condensing.
EMI/RFI Influence	Designed to EN 61326-1
Output Isolation	600 V galvanic isolation
Filter	Adjustable 0-9.9 minutes additional damping to 90% step input
Temperature Input	Pt100 RTD with automatic compensation
Sensor	3-electrode polarographic membrane sensor for direct measurement of H ₂ O ₂
Sensor Materials	PVC
Sensor Cable	1ft. (.3 meter) cable with 6-pin plug.

Flow Cell	Sealed acrylic flowcell factory assembled with polyurethane sample and drain tubing.
Instrument Power	Two alkaline C-cell batteries standard. External 5-17 VDC (10 mA) supply optional.
Battery Life	Approximately 30 days of continuous operation with two high quality alkaline C-Cell batteries. .
Outputs	Two 0-2.5 VDC isolated outputs are provided for connection to data recorders, etc.
Optional Data logger	Removable data module holds total of 32000 points from two user configured channels, time of logging is user configurable.
Software	Data logger software supplied when optional data logger is ordered. Standard software package is PC compatible, but MAC version is available.

1.5 Q45S Performance Specifications

Accuracy	0.5% of selected range or 0.01 PPM
Repeatability	0.3% of selected range or 0.01 PPM
Sensitivity	0.05% of selected range
Non-linearity	0.1% of selected range
Warm-up Time	3 seconds to rated performance (electronics only)
Supply Voltage Effects	± 0.05% span
Instrument Response Time	60 seconds to 90% of step input at lowest damping



Equipment bearing this marking may not be discarded by traditional methods in the European community after August 12 2005 per EU Directive 2002/96/EC. End users must return old equipment to the manufacturer for proper disposal.

Part 2 – System Components

2.1 General

The PQ45 Portable Hydrogen Peroxide Monitoring System comes complete in a rugged molded case, and is designed to be operated by simply setting the case in the desired location, connecting sample and drain tubes, and turning on the power. However, when received, the sensors are not yet ready for use, and the user must first prepare the H₂O₂. Once the system has been readied for use, it can be turned on and off, and moved to various locations without requiring further service.

2.2 Front Panel Components

The PQ45 contains an internal hinged panel. Release the two main case latches and you will see the electronic monitor on the front of the panel with a graphic of the software map located below. The graphic is meant to be a reference for navigating the software in the analyzer. If the optional data logger was ordered, this component will be located just below the monitor, and will have two connectors plugged into the side.



Figure 2 - Front View of Hinged Panel

2.3 Internal Flow System

The “Wet” section of the analyzer is located on the back of the internal hinged panel. The panel is held in place by two captive screws on the right side. Loosen these screws to get access to the sensors and sample flow components. Figure 3 identifies the items located on the back of the panel.



Figure 3 - Sensor and Flow Components

The flow system inside the case consists of quick-disconnect sample and drain fittings, polyurethane tubing, flow control assembly, and either one or two flowcells with sensors. This system is completely assembled and is designed for connection to water sources with pressure between 5 and 75 PSI. Note that the drain tube **MUST** discharge to an unpressurized drain. You may not connect the drain to a pressurized line or the system will not function properly.

Most tubing connections are made using what are called “instant tube fittings”. These fittings are designed to allow tubing to be readily removed in case service is needed on a particular component. This is normally only needed to remove the flow control assembly to clean the y-strainer.

The instant tube fittings have a circular collar at the end of the fitting. This collar must be pushed toward the main body of the fitting while pulling the tubing in the opposite direction. When reinserting the tubing, simply press the tubing into the fitting and you will feel it slide into place.

2.4 Flow Control System

The sample flow to the sensors in this instrument is controlled by a special orifice control device that controls sample flow to approximately 400 cc/min. regardless of variations in inlet pressure. The flow control device is protected by a strainer with clear bowl. This strainer is designed to remove any large particles that might adversely affect the performance of the flow control.

The strainer should be inspected periodically and cleaned of accumulated solids. To do so, simply unscrew the clear bowl. Remove the screen and rinse as needed to remove any accumulated solids.

2.6 Water Sample Connections

On the hinged side of the case are two quick-disconnect fittings marked INLET and OUTLET. This is where you will connect your water sample. These connectors contain valves that automatically close when the mating connector is removed. Mating connectors also contain valves so that sample lines can be disconnected without closing the main tap valve.

A 20-foot (6 m.) length of 0.25” O.D. x 0.17” I.D. polyurethane tubing is supplied for connection to water lines. In addition, tube fittings that mate with either 1/8” NPT or 1/4” NPT sample lines are supplied for convenience.

2.7 Spare Parts

Behind the internal panel in the area of the flowcell and sensor is a molded foam area that holds spare parts that might be needed in the field. The following items are normally supplied.

Qty. 1	Pack of 10 spare sensor membranes
Qty. 1	120 cc. Bottle of sensor electrolyte
Qty. 1	Misc. screw and O-ring kit for sensors.
Qty. 1	Data Logger Software (if purchased with system)
Qty. 2	Quick-disconnect fittings for sample & drain connection
Qty. 4	Water system adapter fittings – two each of 1/8" NPT & 1/4" NPT
20 feet	1/4" O.D. x 0.17" I.D. sample / drain tubing

Any other accessories, spare sensors, membranes, or adapter fittings that were ordered with the system will be stored there if space allows.

Attached inside the front cover is a plastic pouch containing the O&M manual for the instrument.

Part 3 – Sensor Preparation

3.1 Peroxide Sensor Preparation

The H₂O₂ sensor supplied with the PQ45-84 is shipped dry. It will not operate until it is prepared by adding electrolyte and a membrane. Preparation of the sensor for operation must be done carefully. The procedure should be done by a qualified technician, and it should only be done when the system is ready for operation. Until then, it is best to leave the sensor in the condition in which it is received.

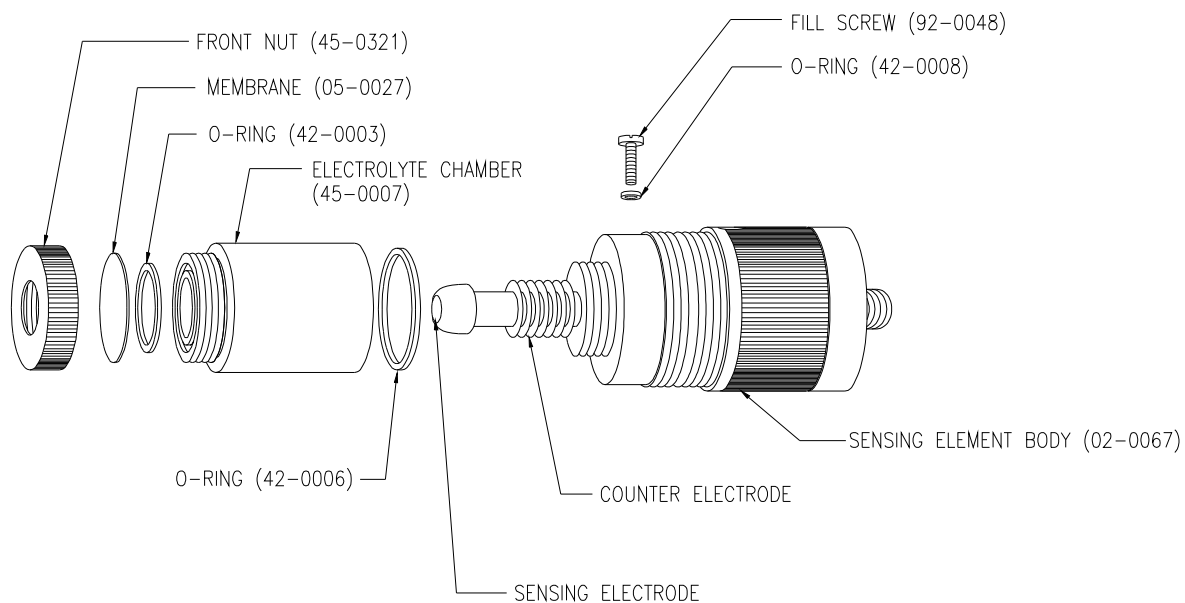

Figure 4 – Peroxide Sensor Assembly

Follow the procedure below to prepare the sensor for operation:

1. Unscrew the electrolyte chamber from the assembled sensor and also remove the fill screw (vent screw) from the side of the sensor body.
2. Remove the front nut from the bottom of the chamber and discard the protective membrane. O-rings are contained in grooves on both the bottom and top of the chamber. Be sure that these o-rings remain in place.
3. From the package of membranes supplied with the sensor, place a new membrane into the front nut. **The membrane is white in color and is separated from other membranes by a light blue paper spacer.**

4. Screw the front nut on to the chamber until you feel the o-ring compress. Hand tight compression is all that is needed. Do not use tools to tighten. The membrane should be flat across the bottom of the chamber without wrinkles.
5. Fill the chamber with electrolyte until the level reaches the bottom of the internal threads.

CAUTION: Use care in handling the sensor electrolyte. Electrolyte contains sulfuric acid that can cause both skin and eye irritation. Should eye contact occur, immediately flush eyes with water and consult a physician. The use of latex gloves is advisable when filling the sensor. Do not get electrolyte on clothing as damage may result.

6. Slowly screw the chamber onto the sensor body. A small amount of electrolyte will run out of the hole from which the vent screw was removed. Place a paper towel around the sensor to absorb the electrolyte overflow. Tighten the chamber until the o-ring at the top of the chamber is compressed. Once again, do not use tools to tighten.
7. Shake excess electrolyte from the vent hole on the side of the sensor and replace the fill screw.

The sensor is now ready for operation. The membrane should be stretched tightly across the tip of the sensor. Screw the sensor into the flowcell on the back of the hinged panel. Note that you do not need to screw the sensor in completely. The seal is made using an o-ring on the body. Simply screw it in until you can easily plug in the connector for the sensor cable. The flowcell should contain enough water to keep the membrane area wet for proper storage. **Be sure to have the drain fitting plugged into the outside port when inserting and removing sensors. When fittings are not connected, trying to remove or insert a sensor will be extremely difficult.**

CAUTION: When handling the assembled sensor, do not set the sensor on its tip or damage to the membrane will result. Severe impacts on the tip of the sensor from dropping or other misuse may cause permanent damage to the sensor.

Part 4 – Electrical Connections

4.1 General

PQ45 Portable Analyzers are factory wired and are ready to operate as received. If units were supplied with the optional data logger, voltage output cables that plug into the logger will be supplied. If no logger was purchased with the unit, these cables will not be installed. Units supplied with the external power and output connector will be provided with a mating cable assembly.

4.2 Sensor Connections

Figure 5 below provides information on the proper connection of sensor cables. This information is for reference only as the connections are made at the factory.

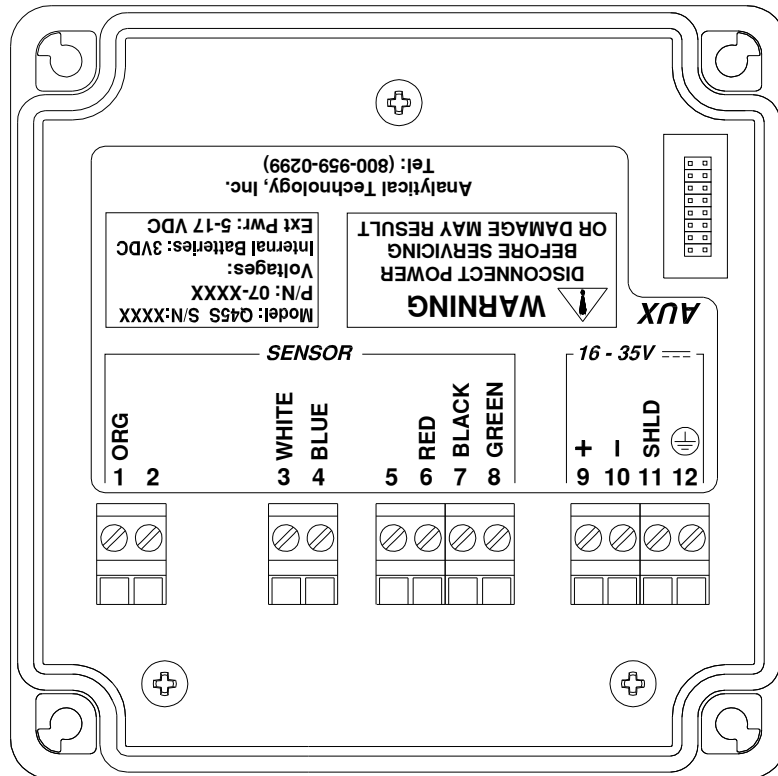

Figure 5 - Sensor Connections, PQ45 H₂O₂ System

4.3 Battery / Power Circuit Board

PQ45S monitors are normally powered by internal C-cell alkaline batteries or by an external power connection. Figure 6 shows this board assembly with batteries installed. Figure 7 shows the same board with terminals installed for external power connection.

The battery circuit board contains 3 switch assemblies as shown in the drawings.

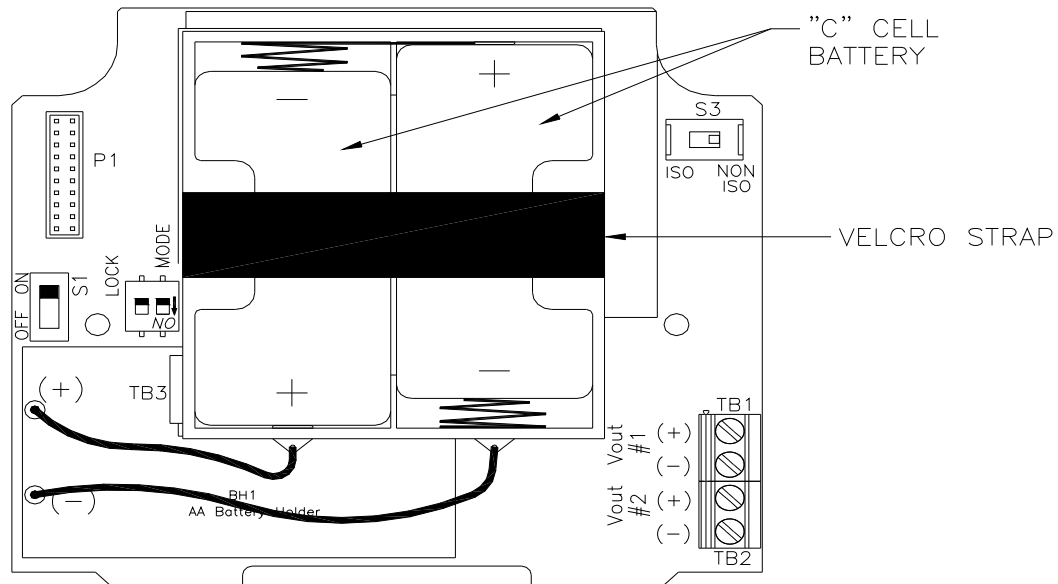

Figure 6 - Battery Circuit Board w/C-Cell Batteries

The first (**S1**) is an On/Off slide switch. This switch must be in the ON position for operation. Turn it to OFF if you do not intend to operate the monitor in the next week or two.

The second switch assembly (**S2**) contains two switches, the one on the left marked LOCK and the one on the right marked MODE. The function of these two slide switches are as follow:

LOCK This switch is used to define how the monitor will turn on and off. This switch is normally in the OFF position. With the lock switch off, the monitor will be turned on manually using the MENU key on the front of the monitor. With the lock switch in the ON position, the monitor will always be on when there is enough power to run the monitor. The ON position is normally used when operating from an external power supply intended for continuous operation.

MODE This switch is used to set the voltage at which monitor will shut off when powered by internal batteries. Alkaline batteries can normally be run down to about 0.75 volts. However, the monitor can be operated using rechargeable nickel-metal hydride (NiMH) batteries as well. This type of battery should not be discharged below about 1 volt before recharging. When using alkaline batteries, the mode switch is in the OFF position (factory default). If rechargeable NiMH batteries are substituted, place the MODE switch in the ON position. Note that rechargeable NiMH batteries have only about 35% of the capacity of an alkaline C-cell, so operation will be limited to about 10 days on a charge. However, NiMH batteries can be recharged hundreds of times.

The third switch assembly is a single slide switch (**S3**) which defines whether the 0-2.5 VDC signals from the monitor are isolated or non-isolated. Output isolation is not required when outputs are connected to the internal data logger. However, if the outputs are connected to external devices through the external connection cable, putting this switch in the ISO position will protect against possible ground loops. The isolation circuit will slightly increase the power requirement for the monitor, resulting in a bit less battery life.

4.4 External Power / Output Connections

PQ45S units ordered with the external connection option are designed for applications where power is to be supplied from an external source, and the two voltage outputs are to be wired to an external device. If that option has been supplied, an interface cable will be provided.

Figure 7 below identifies the terminal connections for external power and voltage outputs. These terminal are factory wired to a connector on the side of the case, and are connected to the outside using the supplied interface cable.

Figure 8 below identifies the color code for signals carried by this interface cable. External power is connected to the red and black wires. The other conductors carry the voltage outputs.

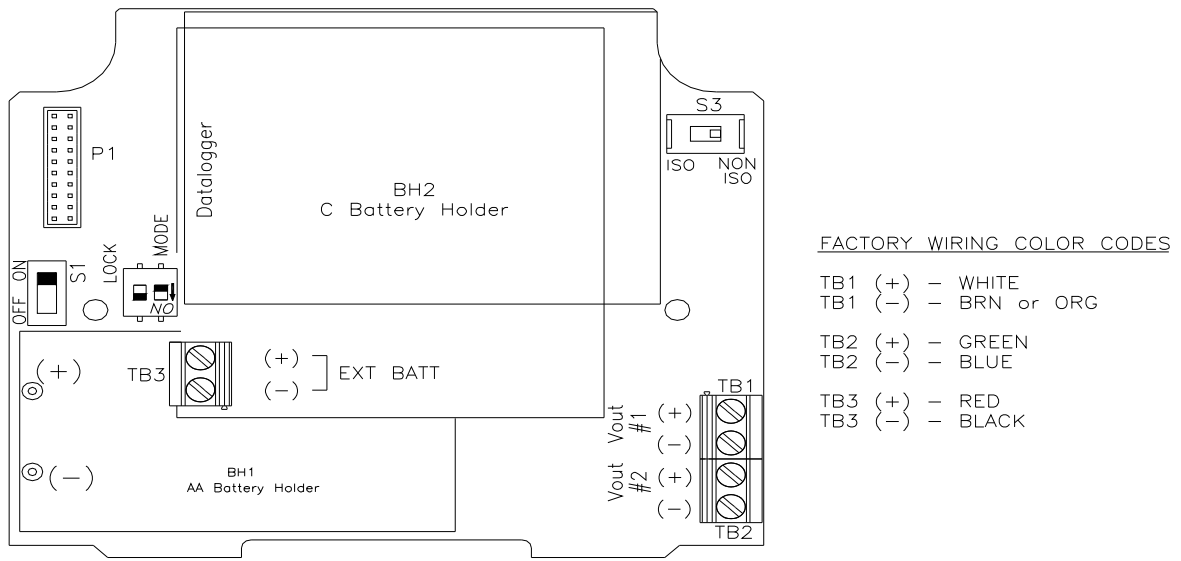

Figure 7 - Battery Circuit Board w/Ext. Power Terminals

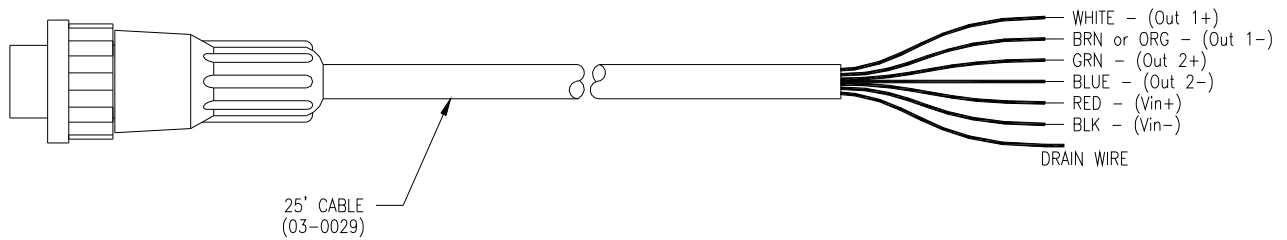

Figure 8 - Ext. Connection Cable Color Code

Part 5 – Operation

5.1 User Interface

To turn the system ON, simply press the MENU key and the display will come on.

Once the instrument is turned on, it will run continuously until it is turned off manually or the batteries are consumed. **To turn the unit off, press and hold the ENTER key until the display shuts off (about 3 seconds). Note that the unit must be in the MEASURE menu in order for the 3-second key press to operate.**

An automatic shut-off feature may be turned on if desired in software. Activating this function will cause the instrument to shut off after 60 minutes of operation. If you wish to operate in this way, turn the Auto-OFF feature to ON in the DIAG menu. This mode is useful when doing short-term measurements.

The normal continuous operating mode is intended for use with the data logger or when the instrument outputs are used for transmitting data. In this mode, the instrument will run continuously until the battery reaches the shutdown level. With the standard two C-cell alkaline batteries, the unit should operate for around 30 days continuously. Using NiMH batteries will decrease this period to about 10 days. Keep in mind that battery life in either case will be influenced by ambient temperature. Cold temperatures will reduce battery capacity.

There is a power (PWR) switch on the battery circuit board that disconnects the batteries. This is normally used only when the system is not to be used for a long period of time (> 3 months of storage). Otherwise, leave this switch in the ON position.

There is a display flag "B" that will flash next to the main measurement indication when the instrument requires battery replacement. If the battery is not replaced, eventually the unit may not turn on in the normal operating mode. Once the low battery condition is indicated, the instrument will only stay powered for about 5 minutes and then will shut down automatically.

Once the electronics are running, connect sample and drain lines from the water source to be monitored. Flow is controlled internally so all that needed is to connect sample and turn on the valve at the water source. Always connect the drain fitting first, followed by the sample inlet, to reduce pressure effects on the sensor.

5.2 Battery Power Circuit Board

The Q45 portable instrument is primarily operated by software settings. However, there are also a few hardware details on the battery circuit board to note.

The battery board is a circuit board that sits in the rear of the Q45 enclosure, and connects to the Q45 AUX port through a ribbon cable. The battery board contains the battery clips for the two C-cell batteries and the output terminal strip for the two 0-2.5 VDC outputs. Along the left side below the ribbon cable is an ON/OFF slide switch. This switch can be used to turn the instrument completely OFF when not intending to use the unit for an extended period. When storing for more than 30 days, remove the batteries.

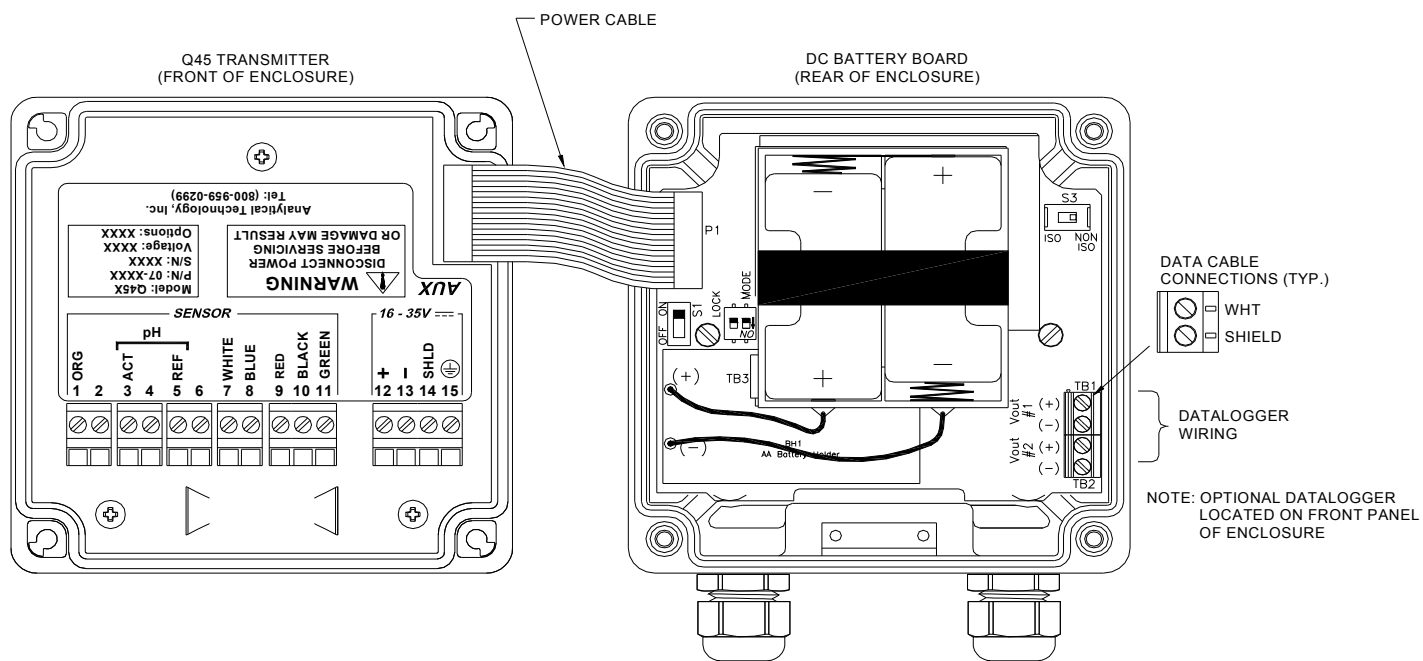

Figure 9 - Battery Board Connection

5.3 Voltage Outputs

There are two analog voltage outputs on the battery board with a terminal strip located in the lower right corner. The outputs are 0-2.5 VDC and may be used to send isolated data the optional PQ45 data logger or to remotely located recorders, PLC's, etc. Output #1 is used only for residual chlorine, and Output #2 can be used for either temperature or peroxide.

5.4 External Power

PQ45 monitors can be powered from external DC supplies. This type of power requires that units be purchased with the optional external connector and mating adapter cable. This cable is used to run external DC power (5-17 VDC) into the unit, and can also be configured to carry the analog output voltage signals to external devices.

5.5 Data logger Module

For local data recording using the two voltage outputs, the optional data logger is mounted on the PQ45 front panel below the monitor display unit. Interface cables are factory wired to the logger with plugs that easily disconnect when removing the logger for downloads.

For the interface cables, the white lead from the plug connects to (+) and the outer braid connects to (-). The 0 – 2.5 VDC signals from the Q45 are designed to exactly match the input requirement for the data logger module. Once connected, Output #1 and #2 signals are sent directly into the data logger module. The logger is held in place with two screw clips. For downloading of data contained on the data logger module, the module can be quickly removed (and swapped if necessary.) The data-loaded module can be brought to a PC for easy recovery of data, without the requirement of having to bring a PC to the Q45 installation.

5.6 Maintaining Sensor Stability

Sensor stability is maintained as long as the PQ45S electronic unit is turned on. When the electronics are shut off, the sensor bias is removed and time will be required for restabilization when power is turned on again.

5.7 User Interface

The user interface for the Q45 Series instrument consists of a custom display and a membrane keypad. All functions are accessed from this user interface (no internal jumpers, pots, etc.).

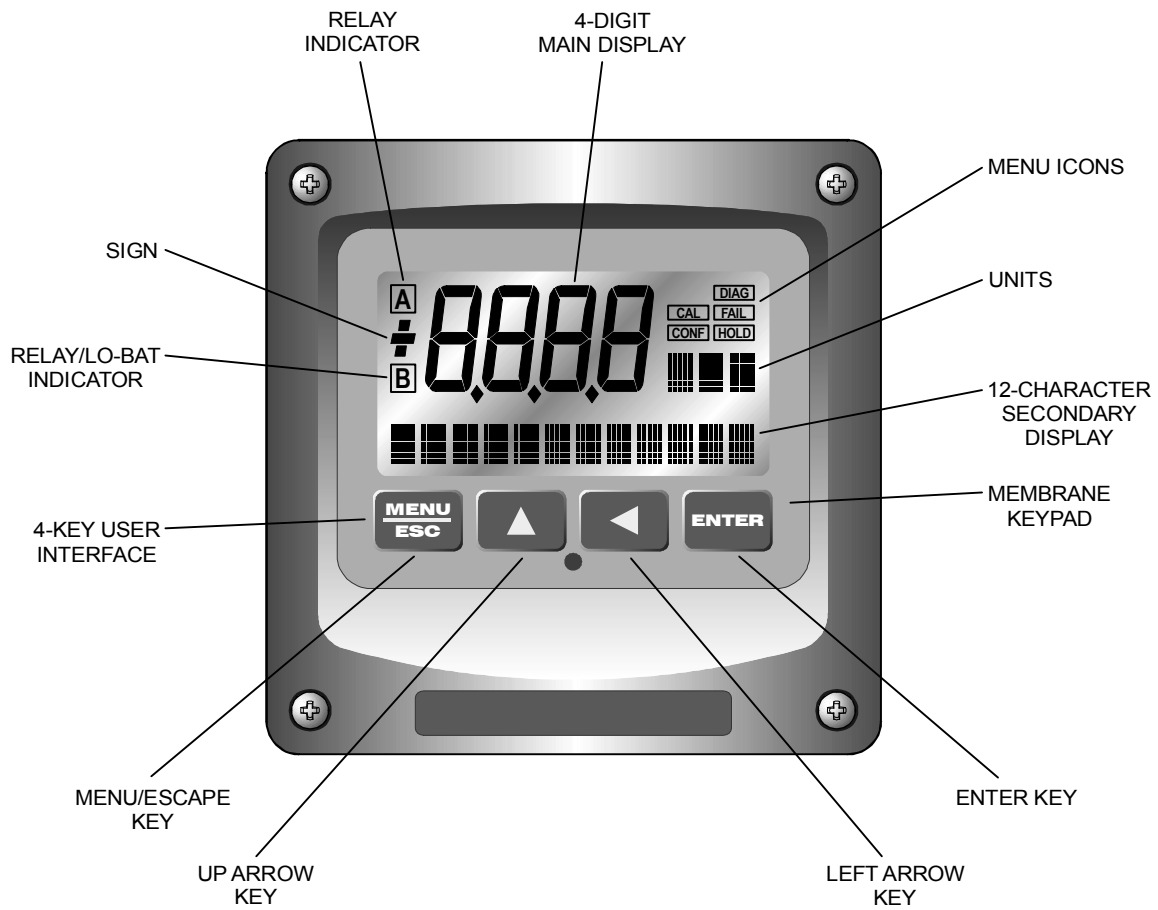

Figure 10 - User Interface

5.71 Keys

All user configurations occur through the use of four membrane keys. These keys are used as follows:

- MENU/ESC** To scroll through the menu section headers or to escape from anywhere in software. The escape sequence allows the user to back out of any changes in a logical manner. Using the escape key aborts all changes to the current screen and backs the user out one level in the software tree. The manual will refer to this key as either MENU or ESC, depending upon its particular function. This is also the ON button.
- UP (arrow)** To scroll through individual list or display items and to change number values.
- LEFT (arrow)** To move the cursor from right to left during changes to a number value.
- ENTER** To select a menu section or list item for change and to store any change.

5.72 Display

The large custom display provides clear information for general measurement use and user configuration. The display contains a back-light to allow good visibility under any conditions. In the default mode of operation, the back-light will come on when any key is pressed and will remain on for about 30 seconds after a key has been pressed. The back-light can be turned on or off in the DIAG menu.

There are three main areas of the display: the main parameter display, the secondary message line, and the icon area.

Main Parameter During normal operation, the main parameter display indicates the present process input with sign and units. This main display may be configured to display any of the main measurements that the system provides. During configuration, this area displays other useful set-up information to the user.

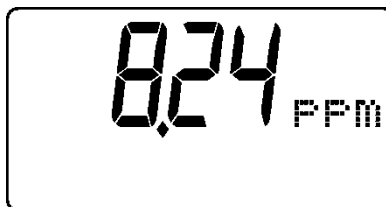

Lower Line

During normal operation, the lower line of the display indicates user-selected secondary measurements that the system is making. This also includes calibration data from the last calibration sequence and the transmitter model number and software version. During configuration, the lower line displays menu items and set-up prompts to the user. Finally, the lower line will display error messages when necessary. For a description of all display messages, refer to Section 9.4 Display Messages

**Icon Area**

The icon area contains display icons that assist the user in set-up and indicate important states of system functions. The CAL, CONFIG, and DIAG icons are used to tell the user what branch of the software tree the user is in while scrolling through the menu items. This improves software map navigation dramatically. Upon entry into a menu, the title is displayed (such as CAL), and then the title disappears to make way for the actual menu item. However, the icon stays on.

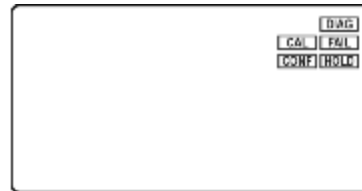
**HOLD**

The HOLD icon indicates that the current output of the transmitter has been put into output hold. In this case, the output is locked to the last input value measured when the HOLD function was entered. HOLD values are retained even if the unit power is cycled.

FAIL

The FAIL icon indicates that the system diagnostic function has detected a problem that requires immediate attention. This icon is automatically cleared once the problem has been resolved.

Icon B

The left screen area contains one “B” icon that indicates that the battery voltage is at a low level. (The “A” indicator is not used in battery-powered units).

**5.8 Software**

The software of the Q45S is organized in an easy to follow menu-based system. All user settings are organized under five menu sections: Measure, Calibration [CAL], Configuration [CONFIG], Control [CONTROL] and Diagnostics [DIAG].

Note: The default Measure Menu is display-only and has no menu icon.

5.81 Software Navigation

Within the CAL, CONFIG, CONTROL, and DIAG menu sections is a list of selectable items. Once a menu section (such as CONFIG) has been selected with the MENU key, the user can access the item list in this section by pressing either the ENTER key or the UP arrow key. The list items can then be scrolled through using the UP arrow key. Once the last item is reached, the list wraps around and the first list item is shown again. The items in the menu sections are organized such that more frequently used functions are first, while more permanent function settings are later in the list. See Figure 11 for a visual description of the software.

Each list item allows a change to a stored system variable. List items are designed in one of two forms: simple single variable, or multiple variable sequences. In the single variable format, the user can quickly modify one parameter - for example, changing temperature display units from °F to °C. In the multiple variable sequence, variables are changed as the result of some process. For example, the calibration of peroxide generally requires more than one piece of information to be entered. The majority of the menu items in the software consist of the single variable format type.

Any data that may be changed will be flashing. This flashing indicates user entry mode and is initiated by pressing the ENTER key. The UP arrow key will increase a flashing digit from 0 to 9. The LEFT arrow key moves the flashing digit from right to left. Once the change has been completed, pressing ENTER

again stores the variable and stops the flashing. Pressing ESC aborts the change and also exits user entry mode.

The starting (default) screen is always the Measure Menu. The UP arrow key is used to select the desired display. From anywhere in this section the user can press the MENU key to select one of the four Menu Sections.

The UP arrow icon next to all list items on the display is a reminder to scroll through the list using the UP arrow key.

To select a list item for modification, first select the proper menu with the MENU key. Scroll to the list item with the UP arrow key and then press the ENTER key. This tells the system that the user wishes to perform a change on that item. For single item type screens, once the user presses the ENTER key, part or all of the variable will begin to flash, indicating that the user may modify that variable using the arrow keys. However, if the instrument is locked, the transmitter will display the message **Locked!** and will not enter user entry mode. The instrument must be unlocked by entering the proper code value to allow authorized changes to user entered values. Once the variable has been reset, pressing the ENTER key again causes the change to be stored and the flashing to stop. The message **Accepted!** will be displayed if the change is within pre-defined variable limits. If the user decides not to modify the value after it has already been partially changed, pressing the ESC key aborts the modification and returns the entry to its original stored value.

In a menu item which is a multiple variable sequence type, once the ENTER key is pressed there may be several prompts and sequences that are run to complete the modification. The ESC key can always be used to abort the sequence without changing any stored variables.

Note that some menu items do not always show up on the display.

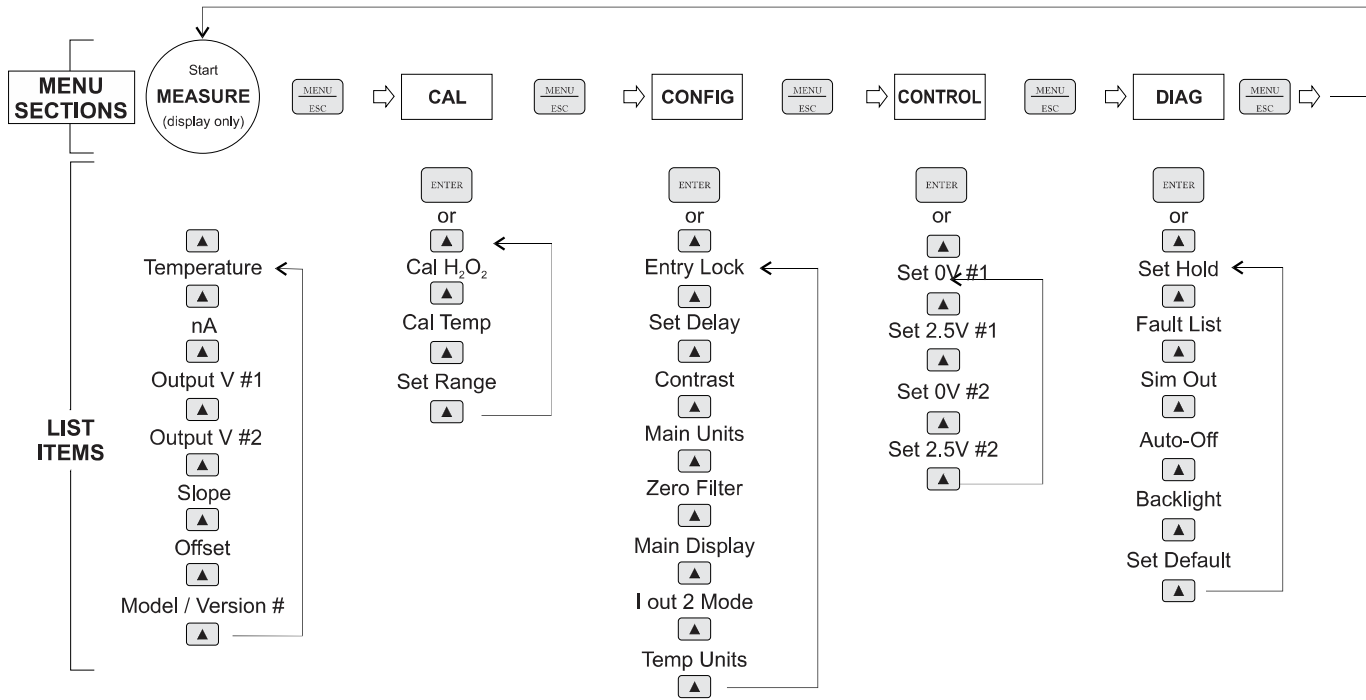

Figure 11 - Software Map

5.82 Measure Menu [MEASURE]

The default menu for the system is the display-only menu MEASURE. This menu is a display-only measurement menu, and has no changeable list items. When left alone, the instrument will automatically return to this menu after approximately 30 minutes. While in the default menu, the UP arrow allows the user to scroll through the secondary variables on the lower line of the display. A brief description of the fields in the basic transmitter version is as follows:

TRANSMITTER MEAS SCREENS:

25.7°C	Temperature display. Can be displayed in °C or °F, depending on user selection. A small “m” on the left side of the screen indicates the transmitter has automatically jumped to a manual 25°C setting due to a failure with the temperature signal input.
32.0 nA	Raw sensor current. Useful for diagnosing problems.
#1 1.05 Vdc	Instrument output signal #1.
#2 0.66 Vdc	Instrument output signal #2.
Slope = 100%	Sensor output response vs. ideal calibration. This value updates after each calibration. As the sensor ages, the slope reading will decay indicating sensor aging. Useful for resolving sensor problems.
Offset = 0.0 nA	Sensor output current at a zero ppm input. This value updates after a zero-calibration has been performed. Useful for resolving sensor problems.
Q45S0 v X.XX	Transmitter software version number.

Note: A display test (all segments ON) can be actuated by pressing and holding the ENTER key while viewing the model/version number.

The MEASURE screens are intended to be used as a very quick means of looking up critical values during operation or troubleshooting.

5.83 Calibration Menu [CAL]

The calibration menu contains items for frequent calibration of user parameters. There are four items in this list: Cal H₂O₂, Cal Temp, and Cal Zero.

Cal H₂O₂ The Hydrogen Peroxide calibration function allows the user to adjust the transmitter span reading to match a reference solution, or to set the sensor zero point. See Part 6 – Calibration for more details.

Cal Temp The temperature calibration function allows the user to adjust the offset of the temperature response by a small factor of $\pm 5^{\circ}\text{C}$. The temperature input is factory calibrated to very high accuracy. However, long cable lengths and junction boxes may degrade the accuracy of the temperature measurement in some extreme situations. Therefore, this feature is provided as an adjustment. See Part 6 – Calibration for more details.

Set Range This function allows the user to set the display range of the transmitter to a specific application. Once set, all output functions use this display range to establish configuration settings. Press ENTER to initiate user entry mode, and the value will flash. Use the arrow keys to modify value; available ranges include 200.0 ppb, 2.000 ppm, 20.00 ppm, and 200.0 ppm. Press ENTER to store the new value. The display range does not affect the internal auto ranging scaler and therefore, sensitivity is to specification in any user selected range.

5.84 Configuration Menu [CONFIG]

The Configuration Menu contains all of the general user settings:

Entry Lock This function allows the user to lock out unauthorized tampering with instrument settings. All settings may be viewed while the instrument is locked, but they cannot be modified. The Entry Lock feature is a toggle-type setting; that is, entering the correct code will lock the transmitter and entering the correct code again will unlock it. The code is preset at a fixed value. Press ENTER to initiate user entry mode and the first digit will flash. Use arrow keys to modify value. **See end of manual for the Q45S lock/unlock code.** Press ENTER to toggle lock setting once code is correct. Incorrect codes do not change state of lock condition.

- Set Delay** The delay function sets the amount of damping on the instrument. This function allows the user to apply a first order time delay function to the peroxide measurements being made. Both the display and the output value are affected by the degree of damping. Functions such as calibration are not affected by this parameter. The calibration routines contain their own filtering and stability monitoring functions to minimize the calibration timing. Press ENTER to initiate user entry mode, and the value will flash. Use the arrow keys to modify value; range is 0.1 to 9.9 minutes. Press ENTER to store the new value.
- Contrast** This function sets the contrast level for the display. The custom display is designed with a wide temperature range, Super-Twist Nematic (STN) fluid.
- The STN display provides the highest possible contrast and widest viewing angle under all conditions. Contrast control of this type of display is generally not necessary, so contrast control is provided as a means for possible adjustment due to aging at extreme ranges. In addition, the display has an automatic temperature compensation network. Press ENTER to initiate user entry mode, and the value will flash. Use arrow keys to modify the value; range is 0 to 8 (0 being lightest). Press ENTER to update and store the new value.
- Main Units** This function sets the display units for peroxide measurement. Press ENTER to initiate user entry mode, and the entire value will flash. Use the UP arrow key to modify the desired display value. The choices are PPM or mg/l. Press ENTER to store the new value.
- Zero Filter** This function forces the reading to zero when reading is below the entered value. For example, If the entered value were 0.0020 the display at 0.0019 would then indicate 0.0000. This feature is useful in blanking out zero noise.

- Main Display** This function allows the user to change the measurement in the primary display area. The user may select between peroxide, Auto (Auto-Ranging), or sensor temperature. Using this function, the user may choose to put temperature in the main display area and peroxide on the secondary, lower line of the display. Press ENTER to initiate user entry mode, and the entire value will flash. Use the UP arrow key to modify the desired display value. Press ENTER to store the new value.
- *Iout#2 Mode** This function sets analog output #2 for temperature or H₂O₂.
- Temp Units** This function sets the display units for temperature measurement. Press ENTER to initiate user entry mode, and the entire value will flash. Use the UP arrow key to modify the desired display value. The choices are °F and °C. Press ENTER to store the new value.

5.85 Control Menu [CONTROL]

The Control Menu contains all of the output control user settings:

- Set 0V #1
- Set 2.5V #1
- Set 0V #2
- Set 2.5V #2

These functions set the output range for each of the two instrument outputs. The value stored for the 0V point may be higher or lower than the value stored for the 2.5V point.

The entry values are limited to values within the range selected in the “Set Range” parameter under the CAL Menu and must be separated by at least 1% of this range. Use the LEFT arrow key to select the first digit to be modified. Then use the UP and LEFT arrow keys to select the desired numerical value. Press ENTER to store the new value.

Output #1 will always be in units of ppm, as it is fixed to track Hydrogen Peroxide. Output #2 will be in either units of ppm, or °C/°F, depending on whether Hydrogen Peroxide, or temperature is set for Out#2 in the CONFIG menu.

NOTE: If the temperature units are changed between °C and °F (see Temp Units in this section), the default settings for this output will be stored (present data is not converted.)

5.86 Diagnostics Menu [DIAG]

The diagnostics menu contains all of the user settings that are specific to the system diagnostic functions, as well as functions that aid in troubleshooting application problems.

Set Hold

The Set Hold function locks the current loop output values on the present process value, and halts operation of the PID controller. This function can be used prior to calibration, or when removing the sensor from the process, to hold the output in a known state. Once HOLD is released, the outputs return to their normal state of following the process input. The transfer out of HOLD is bumpless on the both analog outputs - that is, the transfer occurs in a smooth manner rather than as an abrupt change. An icon on the display indicates the HOLD state, and the HOLD state is retained even if power is cycled. Press ENTER to initiate user entry mode, and entire value will flash. Use the UP arrow key to modify the desired value, selections are **ON** for engaging the HOLD function, and **OFF** to disengage the function. Press ENTER to store the new value.

The Set Hold function can also hold at an output value specified by the user. To customize the hold value, first turn the HOLD function on. Press the ESC key to go to the DIAG Menu and scroll to Sim Output using the UP arrow key. Press ENTER. Follow the instructions under Sim Output (see following page).

Fault List

The Fault List screen is a read-only screen that allows the user to display the cause of the highest priority failure. The screen indicates the number of faults present in the system and a message detailing the highest priority fault present. Note that some faults can result in multiple displayed failures due to the high number of internal tests occurring. As faults are corrected, they are immediately cleared.

Faults are not stored; therefore, they are immediately removed if power is cycled. If the problem causing the faults still exists, however, faults will be displayed again after power is re-applied and a period of time elapses during which the diagnostic system re-detects them. The

exception to this rule is the calibration failure. When a calibration fails, no corrupt data is stored. Therefore, the system continues to function normally on the data that was present before the calibration was attempted.

After 30 minutes or if power to the transmitter is cycled, the failure for calibration will be cleared until calibration is attempted again. If the problem still exists, the calibration failure will re-occur. Press ENTER to initiate view of the highest priority failure. The display will automatically return to normal after a few seconds.

Sim Out

The Sim Out function allows the user to simulate the peroxide level of the instrument in the user selected display range. The user enters a ppm value directly onto the screen, and the output responds as if it were actually receiving the signal from the sensor. This allows the user to check the function of attached equipment during set-up or troubleshooting. Escaping this screen returns the unit to normal operation. Press ENTER to initiate the user entry mode, and the right-most digit of the value will flash. Use arrow keys to modify desired value.

The starting display value will be the last read value of the input. The output will be under control of the SIM screen until the ESC key is pressed.

Note: If the HOLD function is engaged before the Sim Output function is engaged, the simulated output will remain the same even when the ESC key is pressed. Disengage the HOLD function to return to normal output.

Auto-Off

Enables the automatic shut-off feature for the instrument. If ON, the instrument will automatically shut-off in 60 minutes after no keys are pressed to save power. If OFF, the meter will stay powered continuously until either the internal power switch on the battery board is turned OFF, or the battery voltage drops to the cut-off point (approximately 30 days on a two C-cell alkaline batteries). Press ENTER to initiate user entry mode, and the entire value will flash. Use the UP arrow key to modify the desired display value. The choices are **OFF** and **ON**. Press ENTER to store the new value

BackLight

The Back-light screen is used to set the operating conditions under which the backlight will turn on. The default is AUTO, which configures the light to come on whenever any key is pressed. The light will automatically shut off if no key is pressed for 30 seconds. Other selections are OFF (always off), AL for Alarm, where the light comes on in alarm condition and flashes under a Fail condition, and ON (always on). Do not select ON when using internal batteries for operation, as battery life will be greatly reduced.

Set Default

The Set Default function allows the user to return the instrument back to factory default data for all user settings or for just the calibration default. It is intended to be used as a last resort troubleshooting procedure. All user settings or the calibration settings are returned to the original factory values. Hidden factory calibration data remains unchanged. Press ENTER to initiate user entry mode and select either **CAL** or **ALL** with the UP arrow key. The default CAL routine will reset the zero offset to 0.0 nA and reset the slope to 100%. The default ALL routine will reset all program variables to factory default and should be used with care since it will change any user settings that were programmed in the field.

Part 6 – Calibration

6.1 Hydrogen Peroxide Calibration

Once power is applied, the sensor must be given time to stabilize. This is best done by following the zeroing procedure below. Establishing a stable zero is critical to the proper operation of the monitor. A complete calibration will include zeroing and spanning the sensor. It is generally unnecessary to set the zero at every calibration, however, it should be done during the initial installation.

6.11 H₂O₂ Zero Cal

Hydrogen peroxide sensors have extremely low offset currents at zero. For this reason, it is normally sufficient to simply leave the zero at the factory default of 0.0 nA. As an alternative, an electronic zero can be set by disconnecting the sensor from the cable and performing steps 1-5 below.

The steps below assume that the sensor has been prepared in accordance with section 5.1, Sensor Assembly, earlier in this manual. Note that the 8 hour waiting time in step 2 below is not required if the monitor has been running for 24 hours prior to zeroing. If the unit has been running with the sensor connected, the sensor will normally return to a stable zero within 15 minutes.

1. Connect the sensor to the electronics by plugging the cable plug into the receptacle on the top of the sensor.
2. Place about an inch of water in a small beaker or other convenient container and immerse the tip of the sensor. The water used need not be distilled, but it must not contain hydrogen peroxide. If the sensor is being used for the first time, allow the sensor to sit undisturbed for at least 4 hours. If the sensor has been in use, 30 –60 minutes is normally enough to establish a good zero.
3. Scroll to the CAL menu section using the MENU key and press ENTER or the UP arrow key. **Cal H₂O₂** will then be displayed.
4. Press the ENTER key. The screen will display a flashing **1-Ref** for span calibration or a **2-Zer** for zero calibration. Using the UP arrow key, set for a **2-Zer** zero calibration and press ENTER. The system now begins acquiring data for the sensor zero calibration value. As data is gathered, the units for sensor current in nanoamps (nA) and temperature may flash. Flashing units indicate that this parameter is unstable. The calibration data point acquisition will stop only when the data remains stable for a pre-determined amount of time. This can be overridden by pressing ENTER. If the data remains

unstable for 10 minutes, the calibration will fail and the message **Cal Unstable** will be displayed.

5. If accepted, the screen will display the message **PASS** with the new sensor zero reading (offset), then it will return to the main measurement display. If the calibration fails, a message indicating the cause of the failure will be displayed and the FAIL icon will be turned on. The range of acceptable value for sensor offset is -16nA to +16 nA. Should a FAIL occur, carefully inspect the sensor for a tear in the membrane. It will probably be necessary to rebuild the sensor as described in section 5.4, H₂O₂ Sensor Assembly. Should the offset value remain high and result in calibration failures, review the Service section of this manual, and then contact the service dept. at ATI for further assistance.

The sensor zero offset value in nA from the last zero calibration is displayed on the lower line of the Default Menus for information purposes.

6.12 H₂O₂ Span Cal

Span calibration of the system must be done against a laboratory measurement on the same sample that the sensor is measuring. A sample should be collected from the inlet line feeding the flow cell and quickly analyzed for H₂O₂. When calibrating, it is best to have a reasonably high concentration of H₂O₂ in the system. The higher the value, the smaller will be the calibration errors caused by errors in the laboratory analytical procedure. It is generally preferable to calibrate at values above 2 PPM to reduce calibration errors.

Start flow cell and calibrate system as follows:

1. Place the previously zeroed sensor into the sensor chamber of the flow cell assembly. The sensor is inserted into the side of the flow cell and is sealed in place with a double o-ring. The o-rings are lubricated at the factory to allow the sensor to slide smoothly into place. If insertion becomes difficult, use a small amount of silicon grease to lubricate the o-rings. If the low-volume flow cell is used, screw the sensor into the flow cell until the membrane cap bottoms out on the acrylic flow cell. Do not over-tighten
2. Turn on the inlet water flow to the flow cell and adjust the inlet flow rate so that water is overflowing from the inlet chamber. The best performance will be obtained when some water is always overflowing. This maintains constant flow and pressure on the sensor at all times.
3. Allow the system to operate undisturbed for 10 minutes. Assuming the water contains H₂O₂, the display will be reading positive sensor current values. If the system is stable, the value on the display will increase to some PPM value and remain at that level. At that point, calibration can continue.

4. If the sensor is on-line, the user may want to set the output HOLD feature prior to calibration to lock out any output fluctuations.
5. Scroll to the CAL menu section using the MENU key and press ENTER or the UP arrow key. **Cal H₂O₂** will then be displayed.
6. Press the ENTER key. The screen will display a flashing **1-Ref** for span calibration or a **2-Zer** for zero calibration. Using the UP arrow key, set for a **1-Ref** span calibration and press ENTER.
7. The system now begins acquiring data for the calibration value. As data is gathered, the units for ppm and temperature may flash. Flashing units indicate that this parameter is unstable. The calibration data point acquisition will stop only when the data remains stable for a pre-determined amount of time. This can be overridden by pressing ENTER. If the data remains unstable for 10 minutes, the calibration will fail and the message **Cal Unstable** will be displayed.
8. The screen will display the last measured ppm value and a message will be displayed prompting the user for the lab value. The user must then modify the screen value with the arrow keys and press ENTER. The system then performs the proper checks.
9. If accepted, the screen will display the message **PASS** with the new sensor slope reading, then it will return to the main measurement display. If the calibration fails, a message indicating the cause of the failure will be displayed and the FAIL icon will be turned on. The range of acceptable values for sensor slope is 20% to 250%. It may be necessary to rebuild the sensor as described in section 5.4, H₂O₂ Sensor Assembly. Should the slope value remain out of range and result in calibration failures, review the Service Section of this manual, then contact the service dept. at ATI for further assistance.

The sensor offset value in % from the last span calibration is displayed on the lower line of the Default Menus for information purposes.

6.2 Temperature Calibration

The temperature calibration sequence is essentially a 1-point offset calibration that allows adjustments of approximately ± 5 °C.

The sensor temperature may be calibrated on line, or the sensor can be removed from the process and placed into a known solution temperature reference. In any case, it is critical that the sensor be allowed to reach temperature equilibrium with the solution in order to provide the highest accuracy. When moving the sensor between widely different temperature conditions, it may be necessary to allow the sensor to stabilize as much as one hour before the calibration sequence is initiated. If the sensor is on-line, the user may want to set the output HOLD feature prior to calibration to lock out any output fluctuations.

1. Scroll to the CAL menu section using the MENU key and press ENTER or the UP arrow key.
2. Press the UP arrow key until **Cal Temp** is displayed.
3. Press the ENTER key. The message **Place sensor in solution then press ENTER** will be displayed. Move the sensor into the calibration reference (if it hasn't been moved already) and wait for temperature equilibrium to be achieved. Press ENTER to begin the calibration sequence.
4. The calibration data gathering process will begin. The message **Wait** will flash as data is accumulated and analyzed. The °C or °F symbol may flash periodically if the reading is too unstable.
5. The message **Adjust value - press ENTER** will be displayed, and the right-most digit will begin to flash, indicating that the value can be modified. Using the UP and LEFT arrow keys, modify the value to the known ref solution temperature. Adjustments up to ± 5 °C from the factory calibrated temperature are allowed. Press ENTER.

Once completed, the display will indicate **PASS** or **FAIL**. If the unit fails, the temperature adjustment may be out of range, the sensor may not have achieved complete temperature equilibrium, or there may be a problem with the temperature element. In the event of calibration failure, it is recommended to attempt the calibration again immediately.

Part 7 – Data Logger (Option)

7.1 General

The data logger module is an entirely separate device from the Q45 and is supported by a complete software suite for the PC. The required download cable and software are available as an option (only one download cable and one piece of software is required to download an unlimited number of modules.) The software also sets the recording interval, time stamps, and scaling for the module. The module is removed from the analyzer when setting up or configuring the settings. The logger module itself is a self-contained, battery powered device.

7.2 Removing the Data Logger

The data logger is held in place on the front panel with two screws. The logger clips onto the screws and slides down about ¼". To remove the logger, push it up slightly. You will feel it slide on the retaining screws. After sliding it up, pull it toward you to disengage the screws. Reverse the process to remount the logger.

7.3 Starting Logger

The data logging function is activated using a computer connected through a USB port. The software package is called HOBOWare Pro for Windows (a MAC version is also available). The software and an instruction manual for the software are provided when ordered. The software and the USB to Logger cable are provided in the foam insert behind the hinged panel of the PQ45H.

Prior to operating the logger, the software must be installed on your computer. Insert the software CD into your CD drive and follow the instructions on your computer screen for installation. For convenience, you may wish to install a shortcut icon on your desktop for starting up the HOBOWare Pro software.

The manufacturer of the data logger and software provides a convenient on-line video instruction for using HOBOWare Pro software. From your internet command line, type:

http://www.onsetcomp.com/files/flash/software/HOBOWare_Demo_Launch.swf.

The demo lasts for about 3 minutes and will give you good primer on setting up your logger.

The cable supplied with the software provides a USB connector on one end and a special connector that plugs into the data logger on the other end. If you are using an older computer equipped only with an RS-232 port, special RS-232 to USB cables are available commercially that will allow you to adapt to the logger.

Your data logger will have an initial setup already programmed into it from the factory. This setup is done in order to check the unit prior to shipment. You will need to change the channel scaling to fit your specific requirements. The factory default for the logging interval is 1 minute, which again can be easily changed to suit specific application requirements.

Consult the software manual supplied with the system for details on programming the logger, activating the logging cycle, downloading the logged data, and other aspects of data handling. The HOBOWare Pro software allows you to convert the data contained in the file to either Excel, Lotus 123, or comma delimited text files for manipulation using other programs.

7.4 Logger Battery Replacement

The data logger contains a disposable battery that will normally last over 6 months in continuous operation. The battery condition can be seen on the setup screen in the HOBOWare Pro software. To change the battery, remove the 2 screws from the back of the logger and open the plastic case. Slide the battery out of the holder and replace it with a new battery. The battery type is Sony CR-2032 or equivalent and is widely available in electronics stores, camera stores, and some drug stores and supermarkets. They can also be purchased from ATI if required.

Part 8 – System Maintenance

8.1 General

The PQ45S Dissolved Peroxide System will generally provide unattended operation over long periods of time. With proper care, the system should continue to provide measurements indefinitely. For reliable operation, maintenance on the system must be done on a regular schedule. Keep in mind that preventive maintenance on a regular schedule is much less troublesome than emergency maintenance that always seems to come at the wrong time.

8.2 Analyzer Battery Replacement

No maintenance of the analyzer is required. All that's required is to replace the C-Cell batteries when they become discharged. The batteries are located inside the electronic unit. Loosen the 4 screws in the corners of the electronics and allow the front section to hinge down. A Velcro strap holds the batteries in place. Carefully pull out the strap and then remove and replace the batteries. Pay attention to battery polarity to insure proper operation. Use only high quality batteries in this instrument. Use of poor quality batteries often results in battery acid leakage that will damage the electronics. **If the system will not be used for a period of more than 30 days, remove the batteries from the instrument to avoid possible damage.**

8.3 Peroxide Sensor Maintenance

Sensor maintenance is required for accurate measurements. The primary requirement is simply to keep the sensor membrane clean. The membrane is a micro-porous polymer that is resistant to anything that will be encountered in water streams. However, deposits can form on the surface or in the pores of the membrane, and these deposits will reduce the sensitivity. Certain constituents in water, mainly iron and manganese, will form precipitates. These precipitates can sometimes form a coating on the membrane.

Because membranes are micro-porous, they can be relatively difficult to clean effectively. Immersing the tip of the sensor in 1N nitric acid solution will sometimes remove deposits that cause low sensitivity, but this is not always the case. The recommended practice is to simply replace the membrane when it becomes fouled. To change a membrane, follow the Sensor Assembly procedure on page 14 of this manual. Do not reuse the electrolyte from the sensor when changing a membrane. Always refill with fresh electrolyte. The electrolyte is stable and does not have a limited shelf life.

Refer again to the explanation of the sensor slope number after an accepted span calibration on the lower MEASURE screen. In normal operation, the slope of the sensor output will decrease over time as the membrane becomes fouled. This reduction indicates that the sensor is losing sensitivity to H_2O_2 . It is good practice to replace the membrane if the slope number falls to 30-40%. The value will not go below 20%.

Even if no buildup is apparent on the membrane, it should be changed on a regular schedule. The recommended membrane change interval is every 3 months. For high purity water applications, this can probably be extended if desired, but a more frequent changing interval is a small price to pay for avoiding membrane failure at the wrong time.

While the sensor is disassembled for membrane changing, examine the condition of the o-rings on both ends of the electrolyte chamber. If the o-rings show any signs of damage, replace them with new ones from the spare parts kit. It is good practice to change these o-rings once a year, regardless of their condition.

8.31 Sensor Acid Cleaning

Over an extended operating period, peroxide sensors can slowly accumulate deposits on the surface of the platinum electrode. Typically, this type of buildup occurs over years of operation, but can sometimes occur more quickly in high levels of manganese, iron, or other metals are dissolved in the water. The platinum electrode can be “acid cleaned” using nitric acid solutions.

WARNING

THIS ACID CLEANING PROCEDURE INVOLVES THE USE OF HIGHLY CORROSIVE ACID SOLUTIONS. IT SHOULD ONLY BE COMPLETED BY TRAINED PERSONNEL USING PROTECTIVE EYEWEAR AND GLOVES. IF THERE IS ANY DOUBT ABOUT YOUR ABILITY TO SAFELY ACCOMPLISH THIS PROCEDURE, RETURN THE SENSOR TO ATI FOR FACTORY CLEANING!

To acid clean the electrode assembly, remove the electrolyte chamber from the sensor so that the so that both electrodes are exposed. Then follow the procedure below.

1. Place a small amount of 50% nitric acid solution in a beaker. Put in just enough so that the platinum tip of the sensor can be submerged without any contact with the silver coil.
2. Allow the sensor to soak in this acid solution for 2 minutes. Remove the sensor body and rinse the platinum tip thoroughly with distilled water. Discard the nitric acid safely and according to all environmental regulations.
3. Fill the beaker with distilled water to the level sufficient to submerge both the tip and the silver coil. Do not allow the connector at the back of the sensor to be submerged. Allow the electrodes to soak in distilled water for 30 minutes.
4. Put a new membrane and fresh electrolyte in the electrolyte chamber and reassemble the sensor. Connect to the peroxide monitor electronics and allow the sensor to stabilize for at least 24 hours. The sensor can be placed in the flow cell with chlorinated water running through it during stabilization. However, the readings will not be useful for 24 hours.

8.4 Flow Cell Maintenance

The maintenance on the flow cell is simple cleaning. The flow cell is clear to make examination of the condition of the sensor easier without interfering with operations. The flow cell may be cleaned by wiping or by washing with detergents or dilute acids. Do not try to clean with solvents as the acrylic may craze or crack.

Change the o-ring in the flow cell yearly or if any damage is observed. If insertion of the sensor into the flow cell becomes difficult, use silicon grease to lubricate the o-rings that hold the sensor in place. Use only enough grease to provide surface lubrication. Excess grease could foul the sensor membrane.

Part 9 – Troubleshooting

9.1 General

The information included in this section is intended to be used in an attempt to quickly resolve an operational problem with the system. During any troubleshooting process, it will save the most time if the operator can first determine if the problem is related to the analyzer, sensor, or some external source. Therefore, this section is organized from the approach of excluding any likely external sources, isolating the analyzer, and finally isolating the sensor. If these procedures still do not resolve the operational problems, any results the operator may have noted here will be very helpful when discussing the problem with the factory technical support group.

9.2 External Sources of Problems

To begin this process, review the connections of the system to all external connections.

1. Carefully examine any junction box connections for loose wiring or bad wire stripping. If possible, connect the sensor directly to the analyzer for testing.
2. Check sensor membrane for fouling. Look closely for signs of grease or oil, which may be present. Replace membrane and electrolyte, allow to stabilize, and re-check. The procedure in Section 3.1 Peroxide Sensor Preparation, must be followed when replacing the membrane.
3. Check for ground loops. Although the membrane sensor is electrically isolated from the process water, high frequency sources of electrical noise may still cause erratic behavior in extreme conditions. If readings are very erratic after wiring has been checked, check for a possible AC ground loop by temporarily disconnecting feed and drain lines from the flow cell while there is still water on the inside. The reading should be initially stable and then fall very slowly in a smooth fashion as peroxide is depleted in the static sample.

9.3 Analyzer Tests

1. Disconnect power and completely disconnect all output wiring coming from the analyzer. Remove sensor wiring, relay wiring, and analog output wiring. Re-apply power to the analyzer.
2. Using the Simulate feature, check analog outputs and relays with a DVM.
3. Check cell drive circuit. Place a wire short between terminals WHITE and BLUE. With a digital voltmeter (DVM), measure the voltage between terminals ORANGE and BLUE on the back of the monitor to verify that the millivolt value is actually -400 mV.
4. Check TC drive circuit. Place a wire-short between the GREEN and BLACK terminals. With a DVM, measure the voltage between terminals BLACK and RED to verify the TC drive voltage of about 4.8-5.1 Vdc open circuit. Remove DVM completely and connect a 100 Ohm resistor from the BLACK to RED terminals. The temperature reading should display approximately 0°C and the H₂O₂ reading should display approximately 0 ppm.

9.4 Display Messages

The Q45 Series instruments provide a number of diagnostic messages which indicate problems during normal operation and calibration. These messages appear as prompts on the secondary line of the display or as items on the Fault List.

MESSAGE	DESCRIPTION	POSSIBLE CORRECTION
Max is 200	Entry failed, maximum user value allowed is 200.	Reduce value to ≤ 200
Min is 200	Entry failed, minimum value allowed is 200.	Increase value to ≥ 200
Cal Unstable	Calibration problem, data too unstable to calibrate. Icons will not stop flashing if data is too unstable. User can bypass by pressing ENTER.	Clean sensor, get fresh cal solutions, allow temperature and conductivity readings to fully stabilize, do not handle sensor or cable during calibration.
Out of Range	Input value is outside selected range of the specific list item being configured.	Check manual for limits of the function to be configured.
Locked!	Transmitter security setting is locked.	Enter security code to allow modifications to settings.
Unlocked!	Transmitter security has just been unlocked.	Displayed just after security code has been entered.
Offset High	The sensor zero offset point is out of the acceptable range of -25 to +25 nA.	Check wiring connections to sensor. Allow sensor to operate powered a minimum of 12 hours prior to first zero cal.
Sensor High	The raw signal from the sensor is too high and out of instrument range.	Check wiring connections to sensor.
Sensor Low	The raw signal from the sensor is too low.	Check wiring connections to sensor.
H2O2 High	The Peroxide reading is greater than the maximum of the User-selected range.	The Peroxide reading is over operating limits. Set measuring range to the next highest level.
Temp High	The temperature reading is > 55°C.	The temperature reading is over operating limits. Check wiring and expected temp level. Perform RTD test as described in sensor manual. Recalibrate sensor temperature element if necessary.
Temp Low	The temperature reading is < -10 °C	Same as “Temp High” above.
TC Error	TC may be open or shorted.	Check sensor wiring and perform RTD test as described in sensor manual. Check j-box connections.

Figure 12 - Q45H Display Messages

MESSAGE	DESCRIPTION	POSSIBLE CORRECTION
H2O2 Cal Fail	Failure of Peroxide calibration. FAIL icon will not extinguish until successful calibration has been performed, or 30 minutes passes with no keys being pressed.	Clean sensor redo zero and span calibration. If still failure, sensor slope may be less than 25% or greater than 250%. Perform sensor tests as described in section 9.5. Replace sensor if still failure.
TC Cal Fail	Failure of temperature calibration. FAIL icon will not extinguish until successful calibration has been performed, or 30 minutes passes with no keys being pressed.	Clean sensor, check cal solution temperature and repeat sensor temp calibration. TC calibration function only allows adjustments of +/- 6 °C. If still failure, perform sensor tests as described in section 9.5. Replace sensor if still failure. .
EPROM Fail	Internal nonvolatile memory failure	System failure, consult factory.
Chcksum Fail	Internal software storage error.	System failure, consult factory.
Display Fail	Internal display driver fail.	System failure, consult factory.
Range Cal Fail	Failure of factory temperature calibration.	Consult factory.

Figure 13 - Display Messages (continued)

9.5 Sensor Tests

1. Check the membrane condition. A membrane that is not stretched smoothly across the tip of the sensor will cause unstable measurements. If necessary, change membrane and electrolyte.
2. Residual H₂O₂ sensors can be tested with a digital voltmeter (DVM) to determine if a major sensor problem exists. Follow the steps below to verify sensor integrity:
 - A. Disconnect the six sensor wires from the back of the H₂O₂ monitor. Those wires are color coded white, brown, red, black, and green. Note that the brown wire may be replaced with an orange wire in some cables.
 - B. Remove the electrolyte chamber from the sensor and dry the electrodes with a paper towel.
 - C. Connect a DVM between the white and orange wires. Reading resistance, you should find an open circuit value of infinite resistance. Repeat this test between white and blue wires. There must be no measurable resistance at all between these wires. Any resistance at all indicates either water in the cable connector or the breakdown in an electrode seal.
 - D. Connect a DVM between the red and white wires. The red wire is part of the RTD circuit and the white wire is part of the measuring cell. There should be no connection. Reading resistance, you should find an open circuit value of infinite resistance. Any resistance at all indicates either water in the cable connector or the breakdown in an electrode seal.
 - E. Connect the DVM between the red and black wires. These are the RTD leads, and you should find a resistance value that depends on the temperature. The table below lists the resistance values for various temperatures. Reading resistance between the red and green wires should give exactly the same values as between red and black.

Temperature °C	Resistance Ω
0	100.0
5	101.9
10	103.9
15	105.8
20	107.8
25	109.7
30	111.7
35	113.6
40	115.5
45	117.5
50	119.4

Figure 14 - Pt100 RTD Table

If you suspect that water has gotten into a cable connection on a flow type sensor or into the plug connection of a submersible sensor, disconnect the cable and allow the parts of the sensor to sit in a warm place for 24 hours. If water in the connector is the problem, it should dry out sufficiently to allow normal sensor operation. However, steps 4 and 5 above will have to be repeated after drying to see if the problem is gone.

3. Acid clean the sensor electrodes in accordance with the procedure in section 8.31 Sensor Acid Cleaning.

Spare Parts

<u>Part No.</u>	<u>Description</u>
07-0402	PQ45-84 Dissolved Hydrogen Peroxide Analyzer Electronic Assembly
01-0240	Battery circuit board with dual 0-2.5 VDC output
00-1522	Flowcell for H ₂ O ₂ Sensor
42-0014	O-ring for 00-1522 flowcell
55-0057	Fixed flow regulator, 0.4 LPM
55-0063	Tee Strainer, 80 micron
00-0725	A10-84 D. H ₂ O ₂ Sensor (Flow Type)
31-0177	Sensor cable
05-0027	Membranes, H ₂ O ₂
05-0004	Spare Parts Kit, screw & o-ring, (for flow/In-line sensor)
09-0023	Electrolyte, 4 oz (120 cc), H ₂ O ₂
44-0287	Panel mount inlet/outlet fitting
44-0288	Inlet/Outlet plug in connector

Note: Instrument is supplied with sufficient spare parts for 6-12 months of operation.

Lock/Unlock Code: 1457