



O & M Manual



Model Q46UV Q-Clean System Addendum

Home Office

Analytical Technology, Inc.
6 Iron Bridge Drive
Collegeville, PA 19426
Phone: 800-959-0299
610-917-0991
Fax: 610-917-0992
Email: sales@analyticaltechnology.com

European Office

ATI (UK) Limited
Unit 1 & 2 Gatehead Business Park
Delph New Road, Delph
Saddleworth OL3 5DE
Phone: +44 (0)1457-873-318
Fax: + 44 (0)1457-874-468
Email: sales@atiuk.com

Table of Contents

PART 1 - INTRODUCTION.....	3	PART 3 – MAINTENANCE	7
1.1 General	3	3.1 General	7
1.2 Standard System.....	3	3.2 Tube Replacement	7
1.2 Cleaner Panel Assembly	4	SPARE PARTS.....	9
1.3 Q-Clean Pump.....	5		
1.4 Electrical Wiring.....	6		

Table of Figures

FIGURE 1 – Q46UV PANEL WITH CHEMICAL CLEANER.....	4
FIGURE 2 – Q-CHEM ELECTRICAL CONNECTIONS.....	6

Part 1 - Introduction

1.1 General

This manual is a supplement to the manual for the UV-254/Turbidity Monitor. It covers the installation and operation of the Q-Clean automatic sensor cleaning system.

The Q-Clean is an automatic system that periodically cleans the UV sensor by filling the sensor flowcell with a cleaning chemical. The chemical used is a solution of “Red-B-Gone”, which is used to remove iron and manganese buildup. Red-B-Gone is manufactured by Pro Products and an SDS on this chemical is available at: <https://proproducts.com/sds-sheets/>.

1.2 Standard System

The Q46UV system with chemical cleaner is supplied as an integrated assembly that includes the UV monitor, UV sensor and flowcell assembly, an automatic chemical injection system, a sample flow control valve, and a chemical reservoir. All components are mounted on a support panel and the system is ready for operation once it is mounted and sample is connected.



1.2 Cleaner Panel Assembly

As mentioned previously, Q46UV system with chemical cleaning are supplied already mounted on a 1/4" thick HDPE plate. Figure 1 below shows the assemble system with mounting plate dimensions.

Mount the panel in a location that allows easy access for calibration and maintenance.

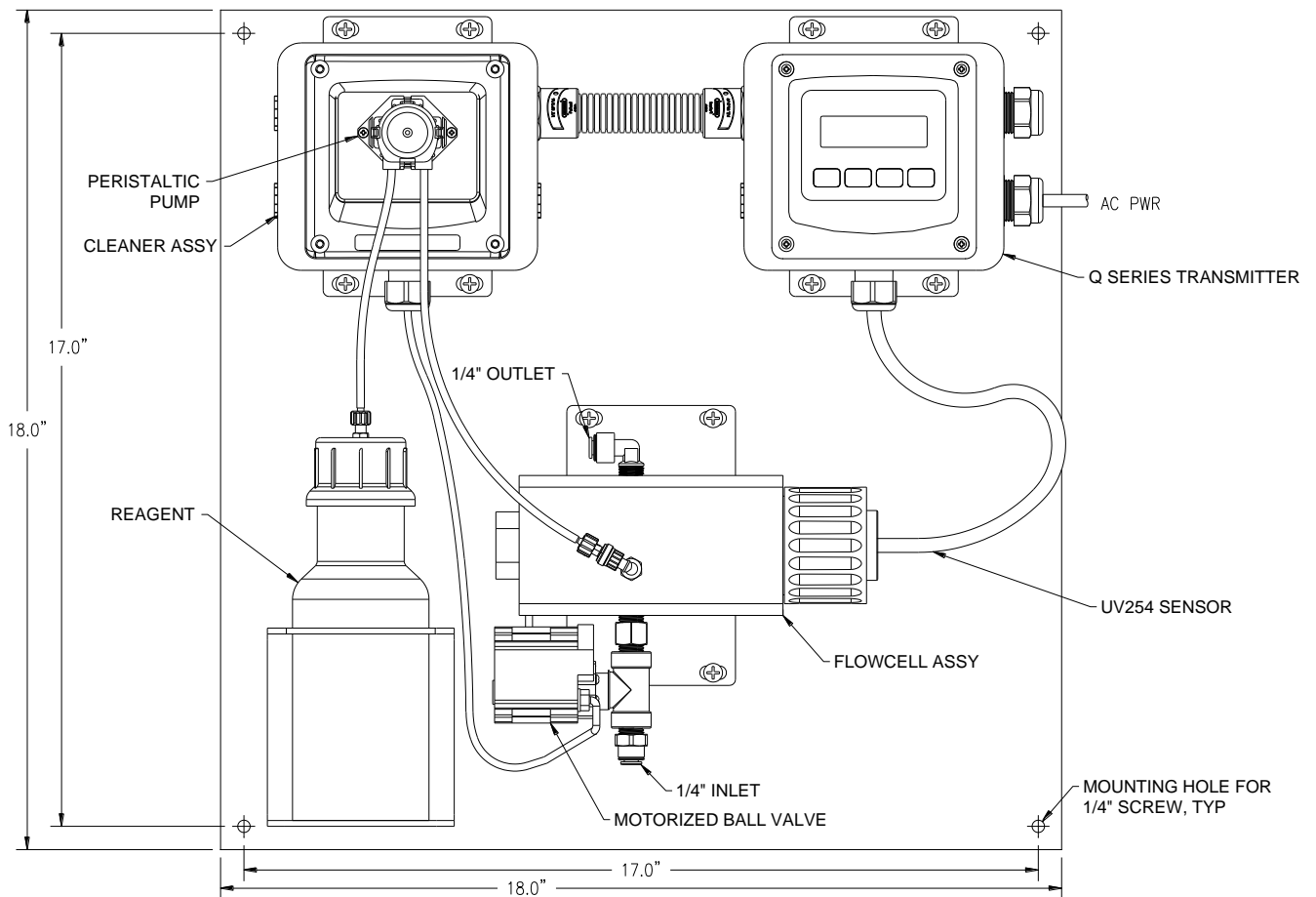

Figure 1 – Q46UV Panel with Chemical Cleaner

1.3 Q-Clean Pump

The Q-Clean assembly uses a peristaltic pump mounted on the front of a control enclosure. The pump operates for approximately 30 seconds during each cleaning sequence. Pump operating time and the frequency of cleaning are controlled by program settings in the Q46UV and can be adjusted to meet specific application requirements.

A typical cleaning cycle will consume approximately 25 ml. of cleaning solution. A 500 ml. chemical bottle is supplied and a bottle bracket is mounted to the panel assembly. Cleaning frequency is normally somewhere between once a day and once a week, depending on the severity of fouling. Only through experience can you determine required frequency.

1.4 Cycle Description

When the Q46 monitor calls for a cleaning cycle to begin, the cleaner assembly will close the ball valve, stopping sample flow into the system. Analog outputs and relays in the Q46 will be held at pre-cleaning values. Once flow has stopped, the peristaltic pump will activate, filling the flowcell with cleaning fluid. After filling, the cleaning solution will remain in the flowcell for the programmed time period (normally about 15 minutes) to clean optical surfaces.

At the end of the cleaning period, the ball valve will reopen and flush out the cleaning solution. Analog and relay outputs will remain in the “hold” state for the period of time defined in the Q46UV program. Once that time period has expired, outputs will update as normal.

1.4 Cleaning Fluid Mixing

The Q-Clean system is supplied with a bottle assembly for holding 500 ml. of cleaning solution. The solution must be mixed on site. A bottle of “Red-B-Gone” cleaner is supplied with the system.

Disconnect the tube fitting at the top of the cleaner bottle and remove the cap. Fill the bottle $\frac{3}{4}$ full of tap water. Add two tablespoons of Red-B-Gone, close the container, and mix for a 30 seconds. Fill the bottle the rest of the way to the neck of the bottle and replace the cap. Place the bottle in the bottle holder and reconnect the tube fitting. Note that the exact amount of chemical is not critical. If using a disposable plastic spoon, simply add 3 or 4 spoonful. A little extra will do no harm and possibly help the cleaning process.

1.4 Electrical Wiring

The Q-Chem pump has two external items connected. A 3-conductor cable connects the Q46UV monitor and a 2-conductor cable connects the sample inlet control valve. In addition, AC power is connected from the Q46UV with a short power cable. If desired, this can be removed and a separate AC power cord used. Shown below are electrical terminal connections for the pump system.

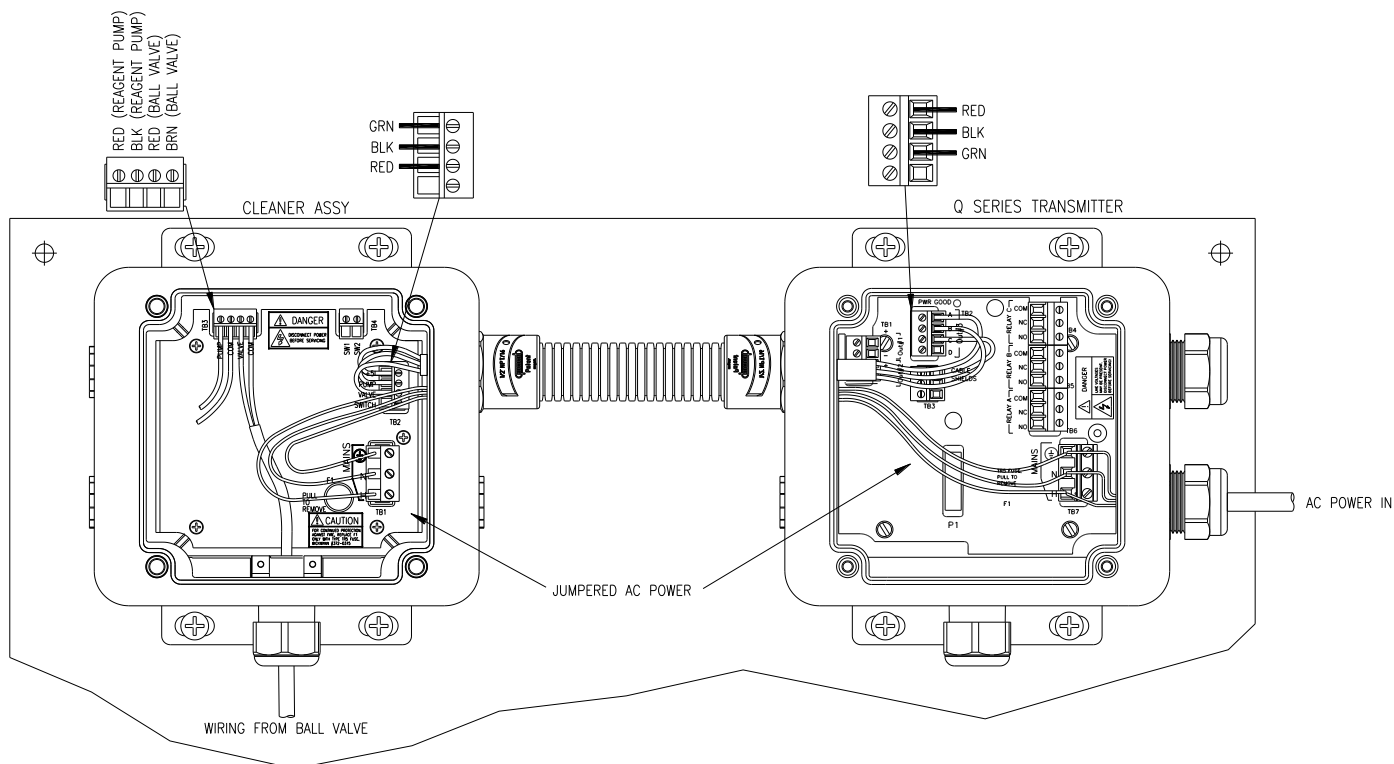

Figure 2 – Q-Chem Electrical Connections

Part 3 – Maintenance

3.1 General

The cleaner system requires very little maintenance. The only maintenance item in the assembly is the peristaltic pump head.

The tubing in the pump is a replaceable part and will need to be changed periodically. The frequency will depend on how often cleaning is done. The pump will normally run about 15 seconds during each cleaning cycle. Assuming one cleaning cycle per day, you can probably go a year without problems. As a preventive procedure, replace the peristaltic pump tubing once per year.

The entire pump and pump motor should last 2-3 years or more, again depending on cleaning frequency. The pumps are inexpensive and replacements are available from ATI.

3.2 Tube Replacement

Tube replacement is a simple process. The peristaltic pump head is first removed from the drive by pinching the tabs on either side inward and then pulling the pump head off of the drive shaft.

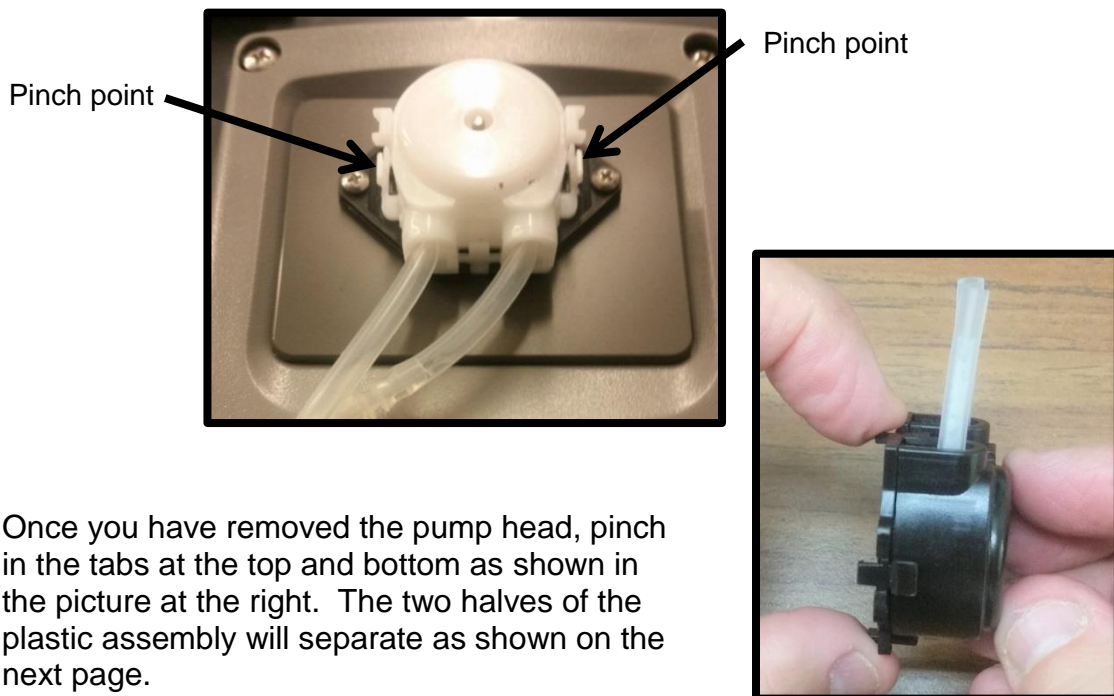

Once you have removed the pump head, pinch in the tabs at the top and bottom as shown in the picture at the right. The two halves of the plastic assembly will separate as shown on the next page.

Inside the pump you'll find a roller assembly and the tube with retainer clips. Take a new piece of tubing from the spares supplied. Place the retainer clips on the new tube. They should be spaced exactly 1" from each end.

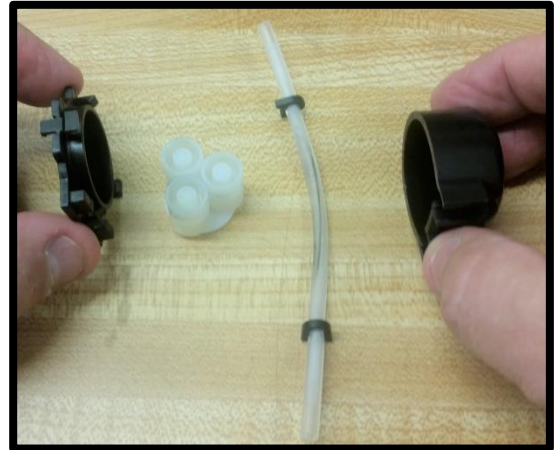

After clips are in place on the tube, wrap the tube around the roller assembly taking care that the clips line up with the slots in the front plastic housing. The opening in the clips faces outward when inserting into the pump head. Press them into place and then replace the back piece.



Once the pump tube is in place, put the pump head back onto the drive shaft and press in until the pinch points click into place so that the pump head is secure.

Spare Parts – Cleaner Pump Assy

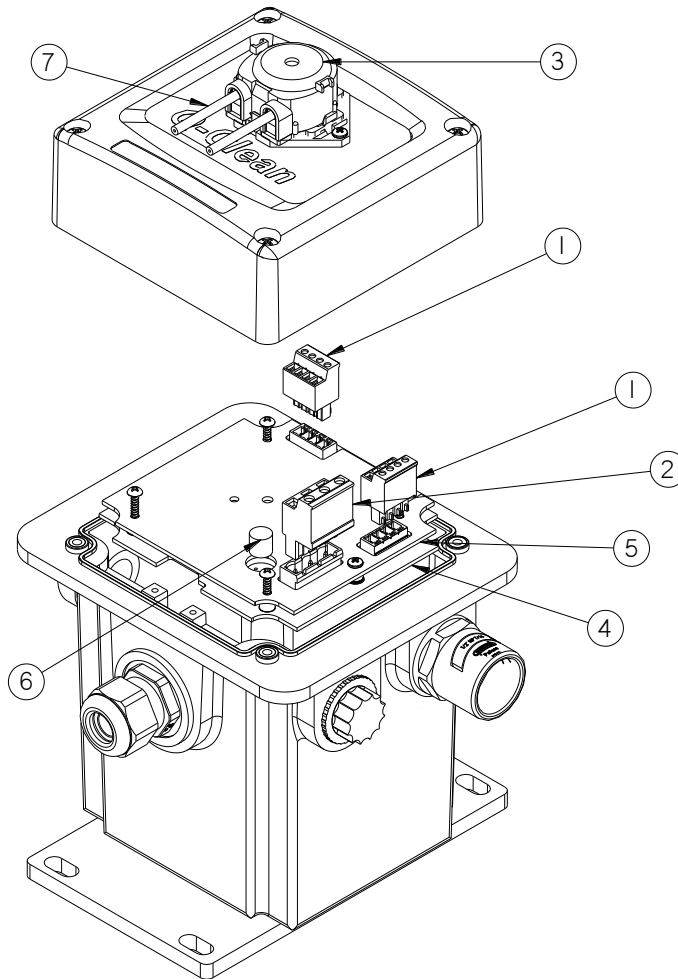

Item Number	ATI_PN	Title
1	38-0073	Plug, 3.81mm, 4 Pos
2	38-0076	Plug, 2 Pos, 3.81mm
3	03-0544	Spare Peristaltic Pump Assy
4	01-0353	Q-Blast P/S PCB Assy
5	01-0354	Q-Blast P/S Cover Board
6	23-0029	Fuse, 630mA
7	05-0143	Pump Tubing Kit

Spare Parts – Flowcell Assy

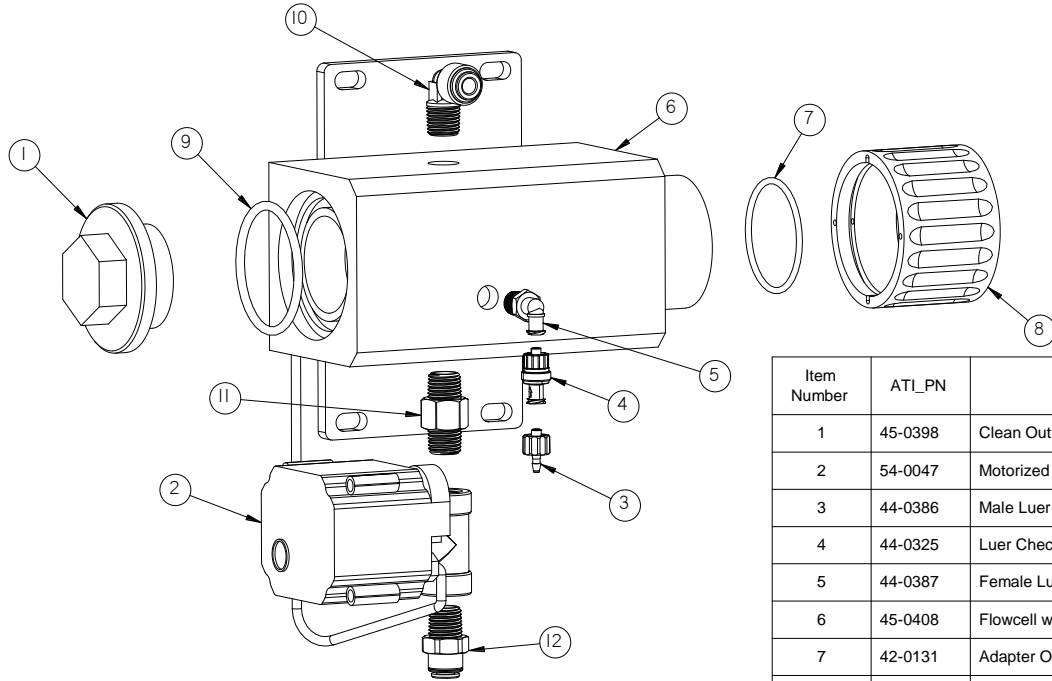

Item Number	ATI_PN	Title
1	45-0398	Clean Out Plug
2	54-0047	Motorized Ball Valve
3	44-0386	Male Luer Fitting x .093" Barb
4	44-0325	Luer Check Valve Fitting
5	44-0387	Female Luer x .125"
6	45-0408	Flowcell w/Cleaner Option
7	42-0131	Adapter O-Ring, 2-131
8	45-0397	Flowcell Cap
9	42-0037	Flowcell O-Ring
10	44-0296	1/4" NPT x 1/4" OD Instant Elbow Fitting
11	47-0135	1/4" S.S. Hex Nipple
12	44-0270	1/4" NPT x 1/4" OD Instant Fitting

PRODUCT WARRANTY

Analytical Technology, Inc. (Manufacturer) warrants to the Customer that if any part(s) of the Manufacturer's equipment proves to be defective in materials or workmanship within the earlier of 18 months of the date of shipment or 12 months of the date of start-up, such defective parts will be repaired or replaced free of charge. Inspection and repairs to products thought to be defective within the warranty period will be completed at the Manufacturer's facilities in Collegeville, PA. Products on which warranty repairs are required shall be shipped freight prepaid to the Manufacturer. The product(s) will be returned freight prepaid and allowed if it is determined by the manufacturer that the part(s) failed due to defective materials or workmanship.

This warranty does not cover consumable items, batteries, or wear items subject to periodic replacement including lamps and fuses.

Gas sensors carry a 12 months from date of shipment warranty and are subject to inspection for evidence of misuse, abuse, alteration, improper storage, or extended exposure to excessive gas concentrations. Should inspection indicate that sensors have failed due to any of the above, the warranty shall not apply.

The Manufacturer assumes no liability for consequential damages of any kind, and the buyer by acceptance of this equipment will assume all liability for the consequences of its use or misuse by the Customer, his employees, or others. A defect within the meaning of this warranty is any part of any piece of a Manufacturer's product which shall, when such part is capable of being renewed, repaired, or replaced, operate to condemn such piece of equipment.

This warranty is in lieu of all other warranties (including without limiting the generality of the foregoing warranties of merchantability and fitness for a particular purpose), guarantees, obligations or liabilities expressed or implied by the Manufacturer or its representatives and by statute or rule of law.

This warranty is void if the Manufacturer's product(s) has been subject to misuse or abuse, or has not been operated or stored in accordance with instructions, or if the serial number has been removed.

Analytical Technology, Inc. makes no other warranty expressed or implied except as stated above.

WATER QUALITY MONITORS

Dissolved Oxygen
Free Chlorine
Combined Chlorine
Total Chlorine
Residual Chlorine Dioxide
Potassium Permanganate
Dissolved Ozone
pH/ORP
Conductivity
Hydrogen Peroxide
Peracetic Acid
Dissolved Sulfide
Residual Sulfite
Fluoride
Dissolved Ammonia
Turbidity
Suspended Solids
Sludge Blanket Level
MetriNet Distribution Monitor

GAS DETECTION PRODUCTS

NH ₃	Ammonia
CO	Carbon Monoxide
H ₂	Hydrogen
NO	Nitric Oxide
O ₂	Oxygen
CO	Cl ₂ Phosgene
Br ₂	Bromine
Cl ₂	Chlorine
ClO ₂	Chlorine Dioxide
F ₂	Fluorine
I ₂	Iodine
H _x	Acid Gases
C ₂ H ₄ O	Ethylene Oxide
C ₂ H ₆ O	Alcohol
O ₃	Ozone
CH ₄	Methane (Combustible Gas)
H ₂ O ₂	Hydrogen Peroxide
HCl	Hydrogen Chloride
HCN	Hydrogen Cyanide
HF	Hydrogen Fluoride
H ₂ S	Hydrogen Sulfide
NO ₂	Nitrogen Dioxide
NO _x	Oxides of Nitrogen
SO ₂	Sulfur Dioxide
H ₂ Se	Hydrogen Selenide
B ₂ H ₆	Diborane
GeH ₄	Germane
AsH ₃	Arsine
PH ₃	Phosphine
SiH ₄	Silane
HCHO	Formaldehyde
C ₂ H ₄ O ₃	Peracetic Acid
DMA	Dimethylamine