

Model Q46N

Dissolved Ammonia Measurement System

Home Office

Analytical Technology, Inc.
6 Iron Bridge Drive
Collegeville, PA19426

Ph: 800-959-0299
610-917-0991

Fax: 610-917-0992

Email: sales@analyticaltechnology.com

European Office

ATI (UK) Limited
Unit 1 & 2 Gatehead Business Park
Delph New Road, Delph
Saddleworth OL3 5DE
Ph: +44 (0)1457-873-318

Fax: + 44 (0)1457-874-468

Email: sales@atiuk.com

PRODUCT WARRANTY

Analytical Technology, Inc. (Manufacturer) warrants to the Customer that if any part(s) of the Manufacturer's equipment proves to be defective in materials or workmanship within the earlier of 18 months of the date of shipment or 12 months of the date of start-up, such defective parts will be repaired or replaced free of charge. Inspection and repairs to products thought to be defective within the warranty period will be completed at the Manufacturer's facilities in Collegeville, PA. Products on which warranty repairs are required shall be shipped freight prepaid to the Manufacturer. The product(s) will be returned freight prepaid and allowed if it is determined by the manufacturer that the part(s) failed due to defective materials or workmanship.

This warranty does not cover consumable items, batteries, or wear items subject to periodic replacement including lamps and fuses.

Gas sensors carry a 12 months from date of shipment warranty and are subject to inspection for evidence of misuse, abuse, alteration, improper storage, or extended exposure to excessive gas concentrations. Should inspection indicate that sensors have failed due to any of the above, the warranty shall not apply.

The Manufacturer assumes no liability for consequential damages of any kind, and the buyer by acceptance of this equipment will assume all liability for the consequences of its use or misuse by the Customer, his employees, or others. A defect within the meaning of this warranty is any part of any piece of a Manufacturer's product which shall, when such part is capable of being renewed, repaired, or replaced, operate to condemn such piece of equipment.

This warranty is in lieu of all other warranties (including without limiting the generality of the foregoing warranties of merchantability and fitness for a particular purpose), guarantees, obligations or liabilities expressed or implied by the Manufacturer or its representatives and by statute or rule of law.

This warranty is void if the Manufacturer's product(s) has been subject to misuse or abuse, or has not been operated or stored in accordance with instructions, or if the serial number has been removed.

Analytical Technology, Inc. makes no other warranty expressed or implied except as stated above

Table of Contents

TABLE OF FIGURES.....	4	PART 6 – CALIBRATION	52
PART 1 - INTRODUCTION	5	6.1 Ammonia Calibration.....	52
1.1 General.....	5	6.11 Ammonia ZeroCal	52
1.2 Standard System	6	6.12 Ammonia SpanCal.....	53
1.3 Features.....	6	6.2 Temperature Calibration	55
1.4 Q46N System Specifications	7	PART 7 – PID CONTROLLER DETAILS	56
1.5 Q46N Performance Specifications.....	9	7.1 PID Description	56
PART 2 – MECHANICAL INSTALLATION	10	7.2 PID Algorithm	56
2.1 General.....	10	7.3 Classical PID Tuning.....	58
2.2 Wall or Pipe Mount.....	13	7.4 Common PID Pitfalls.....	59
2.3 Panel Mount.....	15	PART 8 – SYSTEM MAINTENANCE.....	60
2.4 Chemistry Module Mounting Dimensions	16	8.1 General.....	60
PART 3 – ELECTRICAL INSTALLATION.....	17	8.2 Analyzer Maintenance	60
3.1 General.....	17	8.3 Sensor Maintenance	60
3.2 Monitor Power Connection.....	17	8.31 Sensor Acid Cleaning	61
3.3 Chemistry Module Power Connection.....	22	8.4 Inlet Filter Maintenance	62
PART 4 – CHEMISTRY SYSTEM ASSY	23	8.5 Flow Cell Maintenance	62
4.1 Chemistry Module	23	PART 9 – TROUBLESHOOTING	65
4.2 Sensor Preparation	23	9.1 General.....	65
4.3 Sensor Installation.....	25	9.2 External Sources of Problems.....	65
4.4 Reagent Preparation	25	9.3 Analyzer Tests	66
4.5 Reagent Connections	27	9.4 Chemistry System Tests.....	67
4.6 Reagent Bottle Holders.....	28	9.5 Display Messages	68
4.7 Inlet Filter Assembly.....	29	9.6 Sensor Tests	70
PART 5 – CONFIGURATION.....	30	SPARE PARTS	72
5.1 User Interface.....	30	SPARE PARTS	73
5.11 Keys	31		
5.12 Display.....	31		
.....	31		
5.2 Software.....	33		
5.21 Software Navigation	33		
5.22 Measure Menu [MEASURE].....	36		
5.23 Calibration Menu [CAL].....	37		
5.24 Configuration Menu [CONFIG]	38		
5.25 Control Menu [CONTROL]	42		
5.26 Diagnostics Menu [DIAG].....	47		

Table of Figures

FIGURE 1 - Q46N STANDARD INSTALLATION.....	11
FIGURE 2 - Q46 ENCLOSURE DIMENSIONS.....	12
FIGURE 3 - WALL OR PIPE MOUNT BRACKET.....	13
FIGURE 4 - WALL MOUNTING DIAGRAM.....	14
FIGURE 5 - PIPE MOUNTING DIAGRAM.....	14
FIGURE 6 - PANEL MOUNT AND CUTOUT.....	15
FIGURE 7 - CHEMISTRY SYSTEM DIMENSIONAL.....	16
FIGURE 8 - Q46N AC POWER CONNECTION.....	18
FIGURE 9 - Q46N EXTERNAL CONNECTIONS.....	19
FIGURE 10 - RELAY CONTACTS.....	20
FIGURE 11 - OPTIONAL RELAY BOARD WIRING.....	21
FIGURE 12 - OPTIONAL ANALOG OUTPUT WIRING.....	21
FIGURE 13 - ELECTRICAL CONNECTIONS, SEPARATED SYSTEM.....	22
FIGURE 14 - SENSOR ASSEMBLY.....	24
FIGURE 15 - REAGENT PICKUP ASSEMBLY.....	27
FIGURE 16 - REAGENT BOTTLE HOLDER.....	28
FIGURE 17 - CUSTOMER INLET ASSEMBLY.....	29
FIGURE 18 - USER INTERFACE.....	30
FIGURE 19 - SOFTWARE MAP.....	35
FIGURE 20 - CONTROL RELAY EXAMPLE.....	45
FIGURE 21 - ALARM RELAY EXAMPLES.....	46
FIGURE 22 - ISA (IDEAL) EQUATION.....	57
FIGURE 23 - INLET FLOWBLOCK EXPLODED VIEW.....	63
FIGURE 24 - SYSTEM FITTINGS EXPLODED VIEW.....	64
FIGURE 25 - Q46N DISPLAY MESSAGES.....	68
FIGURE 26 - Q46N DISPLAY MESSAGES (CONT'D).....	69
FIGURE 27 - PT100 RTD TABLE.....	71

Part 1 - Introduction

1.1 General

The Model Q46N is an on-line monitoring system designed for the continuous measurement of dissolved ammonia in aqueous solution. The full scale display range of the system is 0-20.00 ppm, but the chemistry used in the monitor limits the reliable range of operation to 0-5.00 PPM. The sensing system will operate on water streams with temperatures ranging from 5 to 40°C. The Q46N Dissolved Ammonia Measurement System is well suited for potable water systems and wastewater treatment effluents.

The Q46N Dissolved Ammonia Measurement System uses reaction chemistry that converts ammonia in solution to a stable monochloramine compound equivalent in concentration to the original ammonia level. The chloramine concentration is then measured with a unique amperometric sensor that responds linearly to chloramines, while eliminating interference from excess free chlorine in solution.

Sample connections are made to an inlet filtration system attached to the right side of the chemistry system. The inlet filter housing contains two ½" FNPT ports, one on the bottom for inlet and one on the side for outlet. An adapter for ¼" ID tubing is supplied for the inlet and a right angle adapter for 3/8" ID drain tubing is supplied for the outlet. These fittings can be replaced by customer supplied fittings if preferred. The outlet size should always be larger than the inlet to avoid pressurizing the filter system.

The Q46N Ammonia Monitor consists of two separate parts, a wall mounted electronic unit and a separate chemistry system. Because of the special wiring required for communication options available on the Q46, the single box system available in the Q46N model is not available.

Two separate reagents are required for operation. Reagent filter assemblies are included for each, and must be used to insure that no obstructions occur in the reagent tubing. Three feet of pickup tubing is supplied for each reagent.

Reagent pickup assemblies, sensor membranes and electrolyte, spare parts, and a copy of the manual are packed inside the chemistry module for shipment.

1.2 Standard System

The standard model Q46N system includes two main components, the Q46N analyzer and the Chemistry Module. Refer to Figure 1 on page 11 for a typical Q46N installation drawing.

A 25' sensor interconnect cable is supplied for connection of the Q46N electronics to the chemistry module. The separation distance may be increased to 100 ft. by use of a junction box and additional 6 conductor cable. All required spare parts are also provided with the basic system, including spare membranes, electrolyte, o-rings, pump tubing, and any special hardware.

1.3 Features

- Standard Q46N electronic monitors are 100-240 VAC powered. Chemistry systems are either 120 VAC or 220 VAC.
- High accuracy, high sensitivity system, measures from 0.05 ppm to 5.00 ppm.
- Output Hold, Output Simulate, Output Alarm, and Output Delay Functions. All forced changes in output condition include bumpless transfer to provide gradual return to on-line signal levels and to avoid system control shocks on both analog outputs.
- Three 6 amp SPDT relay outputs are standard. Software settings for relay control include setpoint, deadband, phase, delay, and failsafe. An optional 3-relay card, for 0-30 V signals, is available to bring the total to 6 relays.
- Selectable PID controller on main analog output. PID includes manual operation feature, and diagnostic "stuck-controller" timer feature for relay notification of control problems.
- Two analog outputs may be configured to track ammonia and temperature or ammonia and ammonia. Both analog outputs can be individually programmed to fail to specific values. An optional third analog output is available if required.
- Selectable Output Fail Alarm feature on Relay B allows system diagnostic failures to be sent to external monitoring systems.
- Large, high contrast, custom LCD display with LED back light provides excellent readability in any light conditions. The secondary line of display utilizes 5x7 dot matrix characters for clear message display.

- Diagnostic messages provide a clear description of any problem with no confusing error codes to look up. Messages are also included for diagnosing calibration problems.
- Digital communication option for Profibus-DP, Modbus-RTU. More versions pending. See Q46 Digital Communications Manual for Specifications.
- Quick and easy one-point calibration method and sensor zero-cal. To provide high accuracy, all calibration methods include stability monitors that check temperature and main parameter stability before accepting data.
- High accuracy three-wire Pt1000 temperature input. Temperature element can be user calibrated.
- Security lock feature to prevent unauthorized tampering with transmitter settings. All settings can be viewed while locked, but they cannot be changed.

1.4 Q46N System Specifications

Displayed Parameters	Main input, 0.05 ppm to 5.00 ppm Sensor temperature, -10.0 to 55.0 °C (23 to 131 °F) Sensor Current, 0.0–999.9 nA, 0.000 to 99.99 uA Sensor slope/offset Model number and software version PID Controller Status
Main Display Range	0.00 to 20.00 ppm
Display	0.75" (19.1 mm) high 4-digit main display with sign 12-digit secondary display, 0.3" (7.6 mm) 5x7 dot matrix. Integral LED back-light for visibility in the dark.
Keypad	4-key membrane type with tactile feedback, polycarbonate with UV coating
Weight	15.0 lb. (6.82 kg)
Ambient Temperature	Analyzer Service, -20 to 60 °C (-4 to 140 °F) Sensor Service, 2 to 45°C (38 to 131 °F) Storage, -5 to 70 °C (-22 to 158 °F)
Ambient Humidity	0 to 95%, indoor/outdoor use, non-condensing to rated ambient temperature range

Altitude	Up to 2000 m (6562 Ft.)
Electrical Certification	Ordinary Location approval pending, cCSAus (CSA and UL standards), pollution degree 2, installation category 2
EMI/RFI Influence	Designed to EN 61326-1, CE certified
Output Isolation	600 V galvanic isolation
Filter	Adjustable 0-9.9 minutes additional damping to 90% step input
Temperature Input	Pt1000 RTD with automatic compensation
Sensor	Polarographic membraned sensor for direct measurement of chloramines.
Sensor Materials	PVC and stainless steel
Sensor Interconnect Cable	25 ft. (7.5 meter) cable with 6-pin plug.
Max. Sensor-to-Analyzer Distance	100 feet (30.5 meters)
Power	115 or 230 VAC \pm 10%, 50/60 Hz, 10 VA max
Enclosure	NEMA 4X, polycarbonate, stainless steel hardware, weatherproof and corrosion resistant, HWD: 4.9" (124 mm) x 4.9" (124 mm) x 5.5" (139 mm)
Mounting Options	Wall or pipe mount bracket standard. Bracket suitable for either 1.5" or 2" I.D. U-Bolts for pipe mounting. Panel mount adapter optional.
Conduit Openings	Five ½" NPT openings, Adapter can be removed to provide a 1" NPT opening in the bottom of the enclosure. Gland seals provided but not installed.
Relays, Electromechanical:	Three SPDT, 6 amp @ 250 VAC, 5 amp @ 24 VDC contacts. Software selection for setpoint, phase, delay, deadband, hi-lo alarm, and failsafe A-B indicators on main LCD.
Analog Outputs	Two 4-20 mA outputs. Output one programmable for PPM ammonia or PID. Output 2 programmable for PPM ammonia or Temperature. Max load 500 Ohms for each output. Outputs ground isolated and isolated from each other. An additional 3 rd analog option is available.

1.5 Q46N Performance Specifications

Accuracy	1% of selected range or 0.1 PPM
Repeatability	0.5% of selected range or 0.05 PPM
Sensitivity	0.01 PPM
Non-linearity	0.1% of selected range
Warm-up Time	3 seconds to rated performance (electronics only)
Supply Voltage Effects	± 0.05% span
Instrument Response Time	60 seconds to 90% of step input at lowest damping

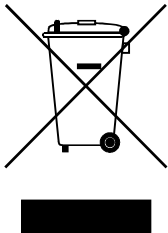

Equipment bearing this marking may not be discarded by traditional methods in the European community after August 12 2005 per EU Directive 2002/96/EC. End users must return old equipment to the manufacturer for proper disposal.

Part 2 – Mechanical Installation

2.1 General

The Q46N Ammonia Monitor includes two parts, an electronic display unit and a chemistry system. Supplied separately, the monitor should be mounted within 25 feet of the chemistry unit. A cable for interconnection of the chemistry module to the monitor is supplied. The connection is already made in the chemistry unit and the monitor connection color code is shown on a label above the connection terminal blocks. The 4-20 mA outputs and relay outputs are available in the Q46N electronic monitor.

The chemistry system is housed in a wall-mount Fiberglass enclosure. To avoid possible shipping damage, the mounting feet for this enclosure are not installed. The feet and attachment screws are supplied with the other accessories.

After the monitor and chemistry system have been mounted and wired, the reagent pickup tubing must be connected to the reagent pump inside the chemistry system. Refer to Figure 1 on the following page. Two 1-gallon reagent bottles are supplied, along with reagent pickup tubing with filter. Feed the end of the pickup tubing through the two small gland seals on the bottom of the enclosure. Connect the tube from the Reagent A bottle to the inlet tubing barb on the reagent pump. The reagent pump has two tubing connection barbs, one on the inside and one on the outside of the holder. Reagent A must be connected to the inside barb. Reagent B must be connected to the outside tube barb. The system will not function properly if these connections are reversed.

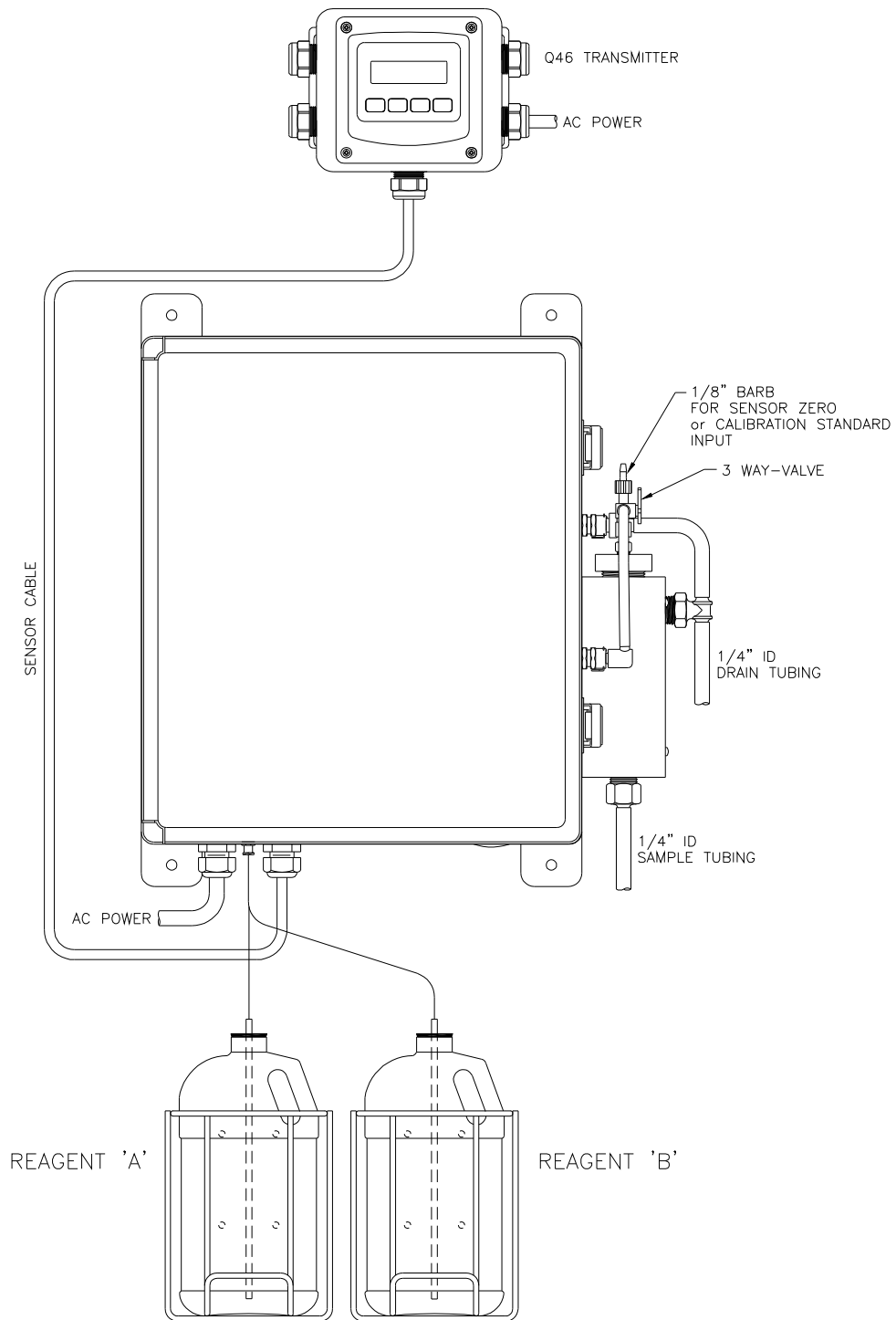

Figure 1 - Q46N Standard Installation

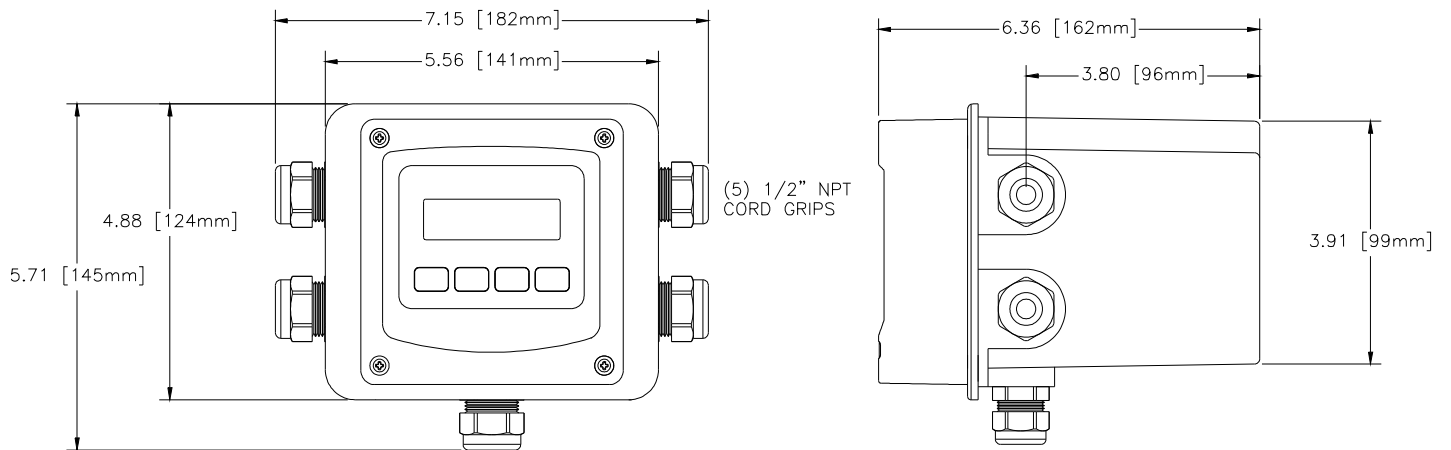

Figure 2 - Q46 Enclosure Dimensions

2.2 Wall or Pipe Mount

A PVC mounting bracket with attachment screws is supplied with each transmitter see Figure 3 for dimensions. The multi-purpose bracket is attached to the rear of the enclosure using the four flat head screws. The instrument is then attached to the wall using the four outer mounting holes in the bracket. These holes are slotted to accommodate two sizes of u-bolt that may be used to pipe mount the unit. Slots will accommodate u-bolts designed for 1½ “or 2” pipe. The actual center-to-center dimensions for the u-bolts are shown in the drawing. Note that these slots are for u-bolts with ¼-20 threads. The 1½” pipe u-bolt (2” I.D. clearance) is available from ATI in type 304 stainless steel under part number 47-0005

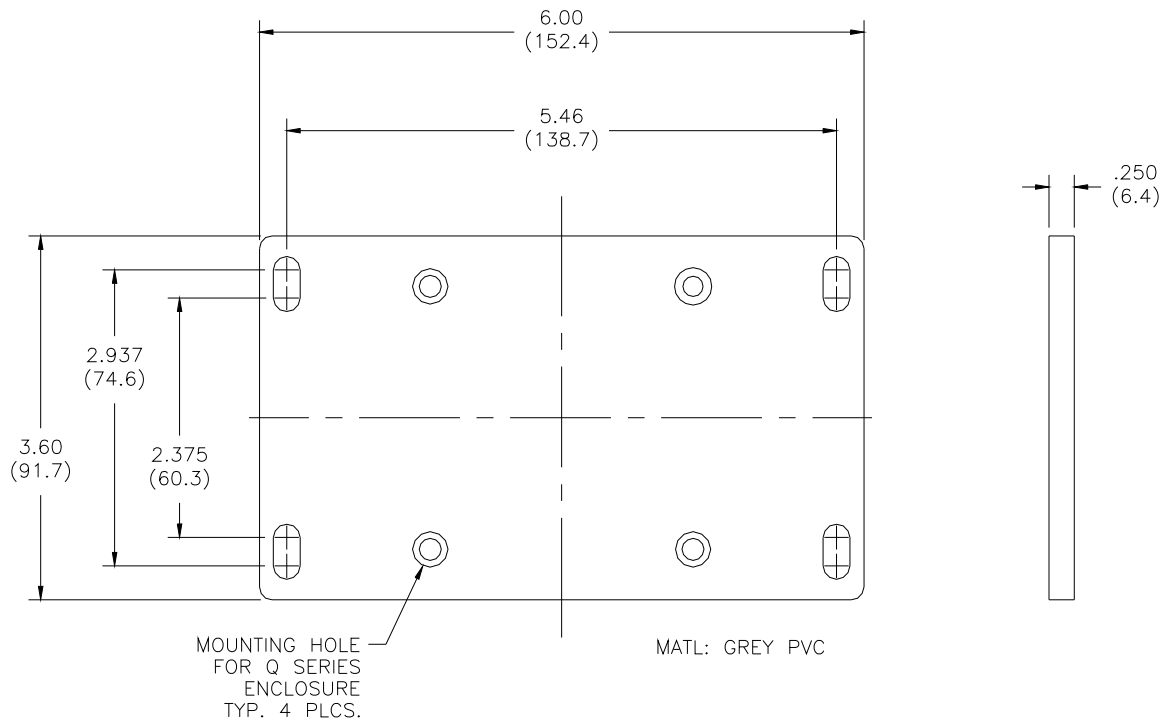

Figure 3 - Wall or Pipe Mount Bracket

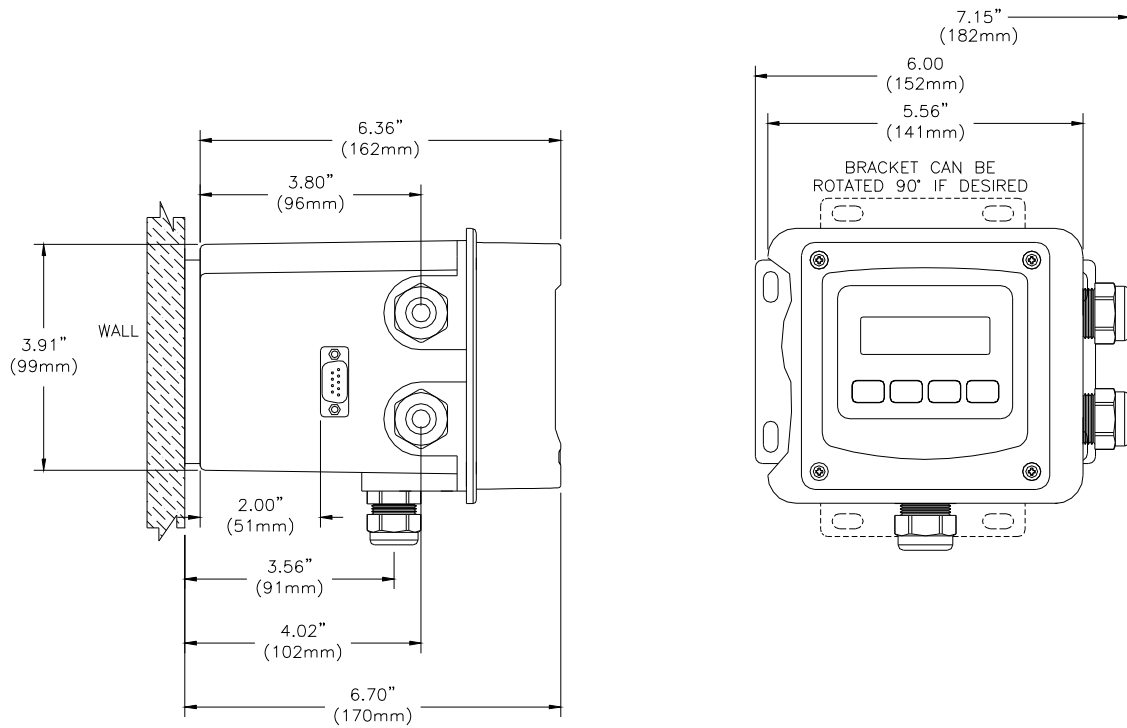

Figure 4 - Wall Mounting Diagram

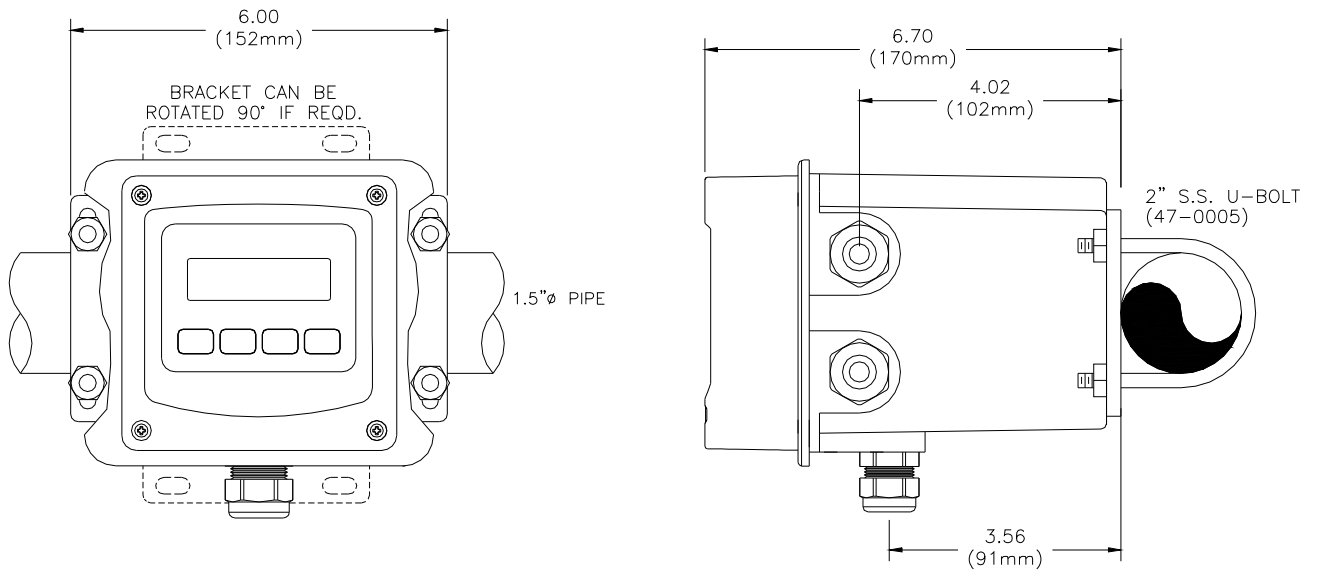

Figure 5 - Pipe Mounting Diagram

2.3 Panel Mount

Panel mounting of a monitor uses the panel-mounting flange molded into the rear section of the enclosure. Figure 6 provides dimensions for the panel cutout required for mounting. The panel mounting bracket kit must be ordered separately (part number 05-0094). This kit contains a metal retainer bracket that attaches to the rear of the enclosure, 4 screws for attachment of this bracket, and a sealing gasket to insure that the panel mounted monitor provides a watertight seal when mounted to a panel.

The sealing gasket must first be attached to the enclosure. The gasket contains an adhesive on one side so that it remains in place on the enclosure. Remove the protective paper from the adhesive side of the gasket and slide the gasket over the back of the enclosure so that the adhesive side lines up with the back of the enclosure flange. Once in place, you can proceed to mount the monitor in the panel.

CAUTION: Panel mounting a Q46 monitor with the Profibus communication option installed may make access to the Profibus connector on the side of the enclosure extremely difficult.

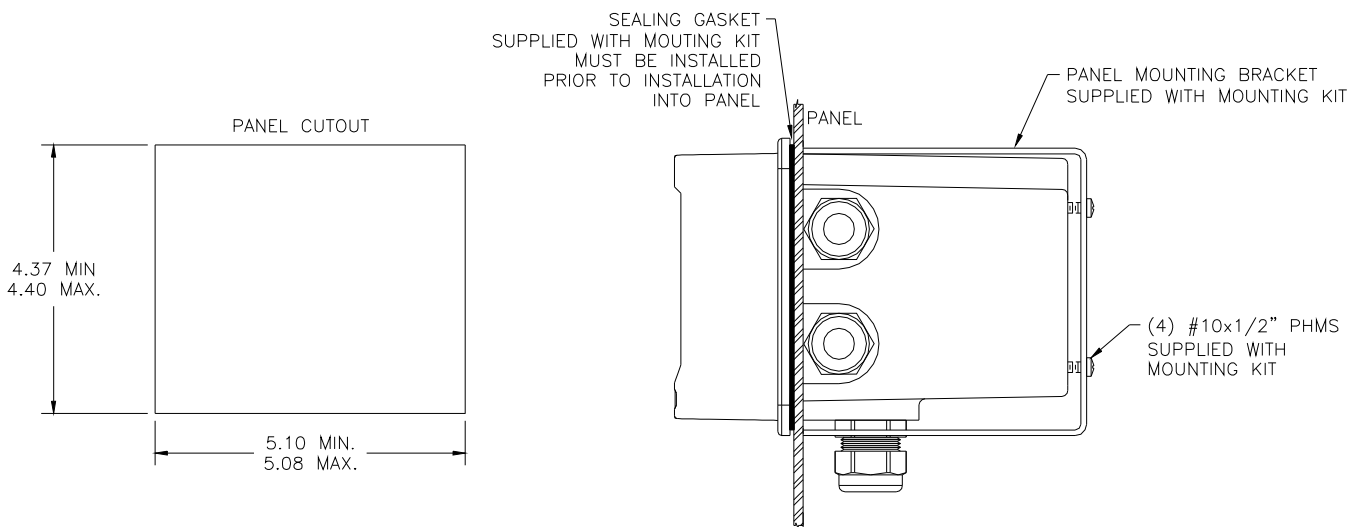

Figure 6 - Panel Mount and Cutout

2.4 Chemistry Module Mounting Dimensions

The chemistry module enclosure is a NEMA 4X Fiberglass unit designed for wall mounting. Figure 7 below shows the dimensions for mounting this enclosure. The mounting brackets for the enclosure are shipped separately to avoid transit damage. The mounting brackets are secured to the enclosure with screws provided. When mounting the enclosure, allow enough clearance on the left side for the door to swing open completely. This will make normal maintenance easier.

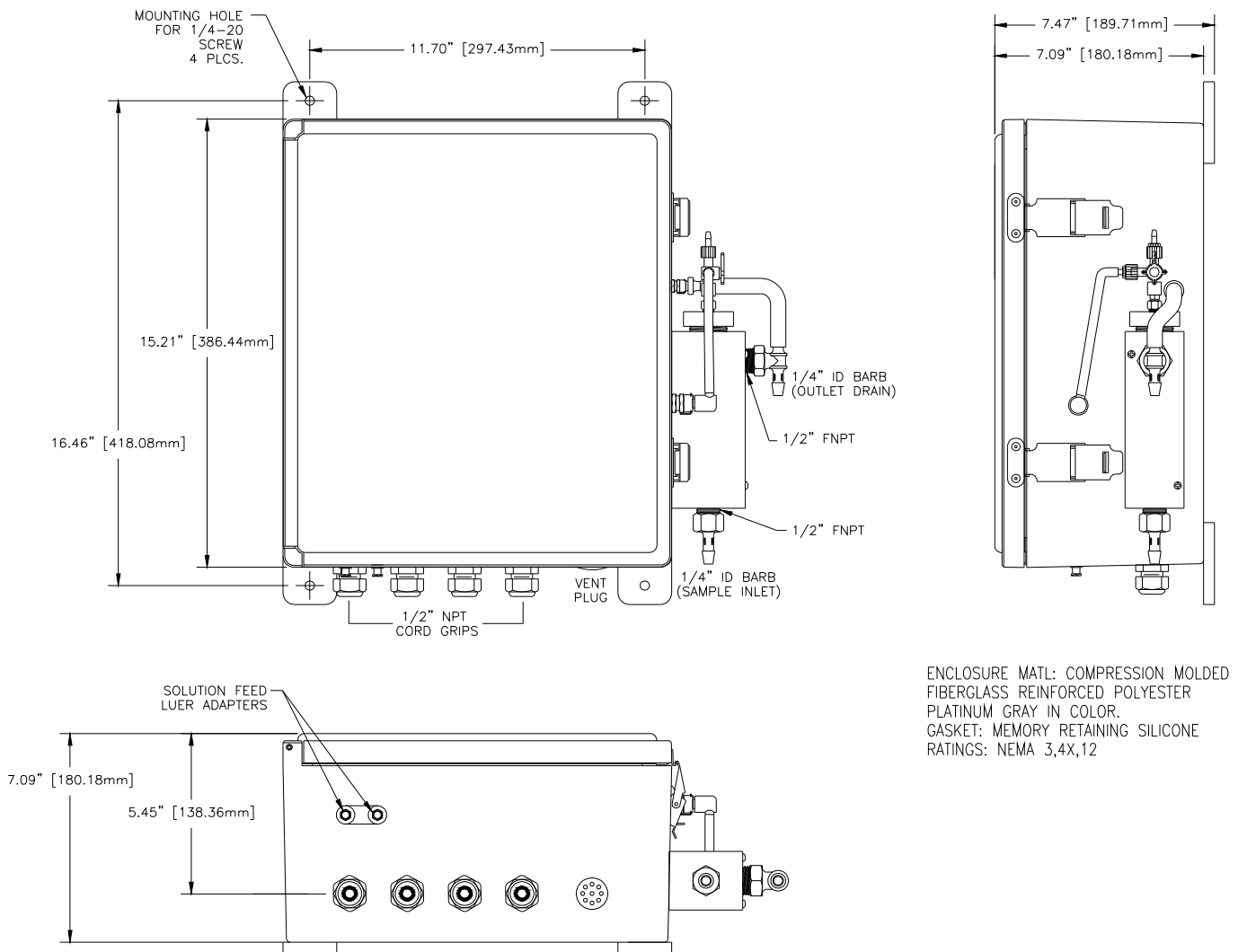

Figure 7 - Chemistry System Dimensional

Part 3 – Electrical Installation

3.1 General

AC power must be connected to BOTH the Q46N electronic assembly and the chemistry system. The electronic monitor uses a universal power supply that will handle any voltage from 100-240 VAC. The chemistry system requires the specific voltage required by the internal pumps, either 120 VAC or 220 VAC. Please verify the chemistry module power marking before connecting any power.

Important Notes:

1. Use wiring practices that conform to all national, state and local electrical codes. For proper safety as well as stable measuring performance, it is important that the earth ground connection be made to a solid ground point. The AC power supply contains a single ¼-Amp slo-blo fuse. The fuse is located adjacent to **TB5** and is easily replaceable.
2. Do NOT run sensor cables or instrument 4-20 mA output wiring in the same conduit that contains AC power wiring. AC power wiring should be run in a dedicated conduit to prevent electrical noise from coupling with the instrumentation signals.
3. This analyzer must be installed by specifically trained personnel in accordance with relevant local codes and instructions contained in this operating manual. Observe the analyzer's technical specifications and input ratings. Proper electrical disconnection means must be provided prior to the electrical power connected to this instrument, such as a circuit breaker - rated 250 VAC, 2 A minimum. If one line of the line power mains is not neutral, use a double-pole mains switch to disconnect the analyzer.

3.2 Monitor Power Connection

A power supply circuit board is mounted into the inside rear of the enclosure. Simply connect any AC source (100-240 VAC \pm 10%) to the terminals shown in Figure 8.

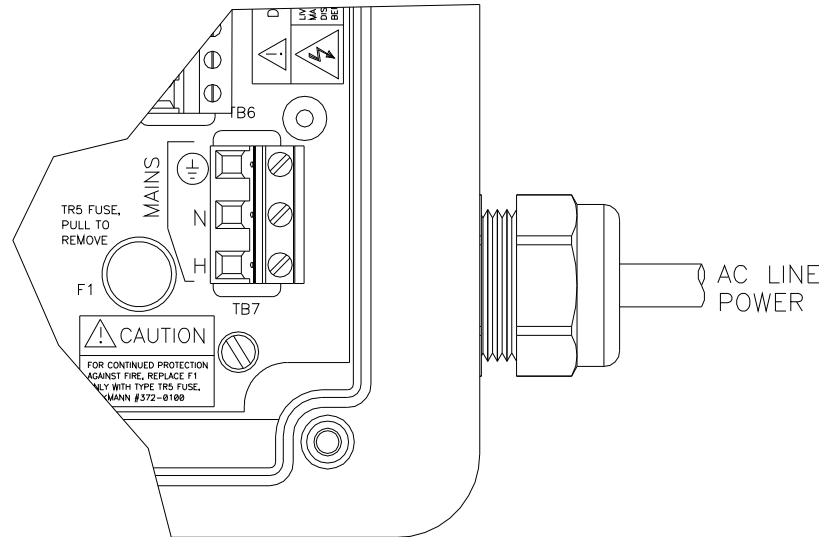

Figure 8 - Q46N AC Power Connection

Q46N systems are supplied with 5 cable gland fittings, two on each side and one on the bottom. Normally, the sensor connection from the chemistry module should come in from the bottom. AC power and relay output wiring should enter from the right side and mA output and optional low voltage relay output from the left. For conduit openings that will not be used, leave the red plugs in place. However, if the installation environment is likely to be wet, it is a good idea to remove the red plugs, wrap the threads with Teflon tape, and reinstall to seal the openings against moisture.

Connect HOT, NEUTRAL, and GROUND to the matching designations on terminal strip **TB5**.

WARNING

Disconnect line power voltage BEFORE connecting line power wires to Terminal TB5 of the power supply. The power supply accepts only standard three-wire single phase power. The power supply is configured for 115 VAC or 230 VAC operation at the factory at time of order, and the power supply is labeled as such. Do NOT connect voltages other than the labeled requirement to the input.

The analog outputs from the system are present at terminal TB1. The loop-load limitation in this configuration is 500 Ohms maximum for each output. Also note that these two outputs are completely isolated from each other to insure that ground loops do not result from the connection of both outputs to the same device such as a PLC or DCS.

A ribbon cable connects the power supply assembly with the microprocessor assembly located in the front section of the enclosure. This cable should not be removed during installation.

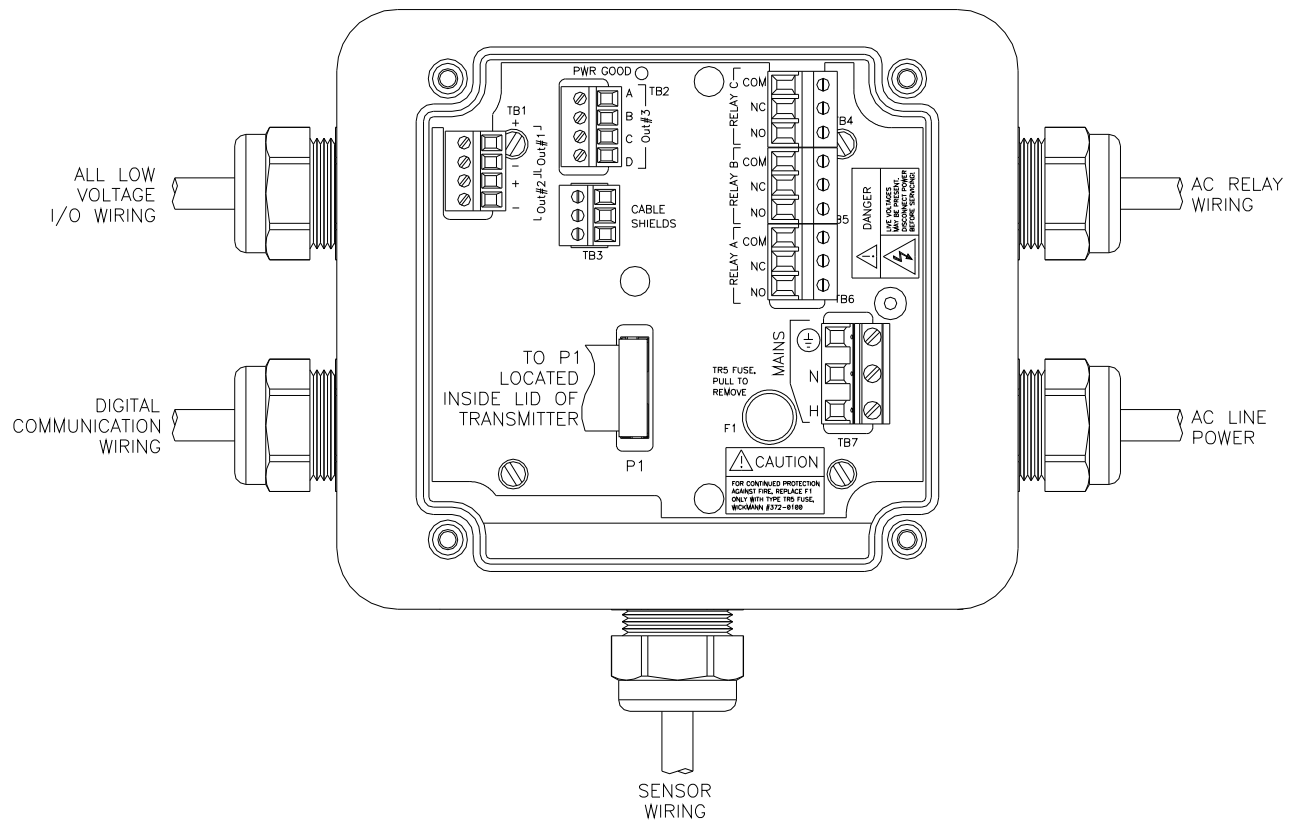
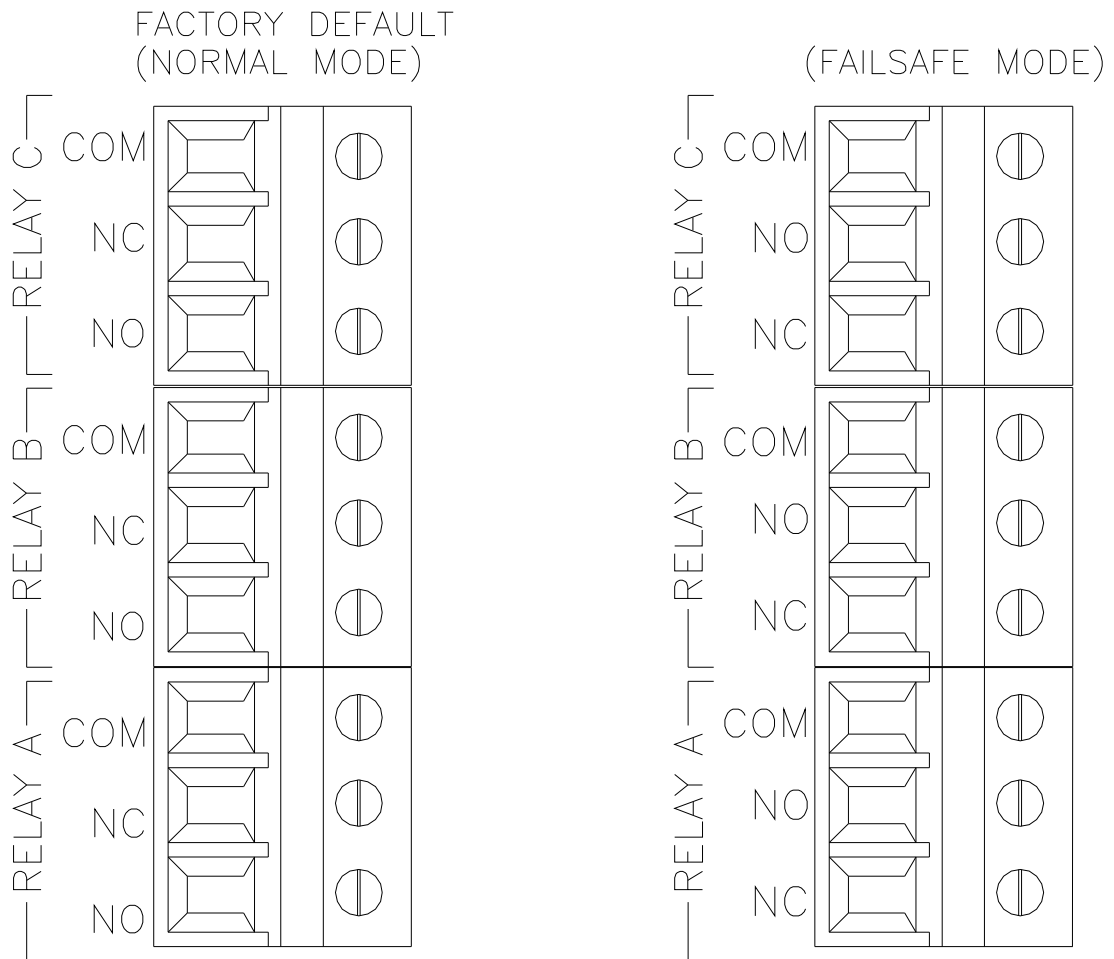

Figure 9 - Q46N External Connections

The power strip, **TB5**, allows up to 12 AWG wire. A wire gauge of 16 AWG is recommended to allow for an easy pass-through into the ½” NPT ports when wiring.

Three SPDT relays are provided on the power supply board. None of the relay contacts are powered. The user must supply the proper power to the contacts. For applications that require the same switched operating voltage as the Q46 (115 or 230 V), power may be jumpered from the power input terminals at **TB7**. Relay wiring is connected at **TB4**, **TB5**, and **TB6** as shown below. Note that the relay contact markings are shown in the NORMAL mode. Programming a relay for “Failsafe” operation reverses the NO and NC positions in this diagram (Figure 10).



Figure

TB2 is used to connect to the optional 3-relay card **Figure 11** **OR** the optional third analog output **Out#3**, **Figure 12**. The Q46 can be configured for only one of these optional features, and the hardware for either option must be factory installed.

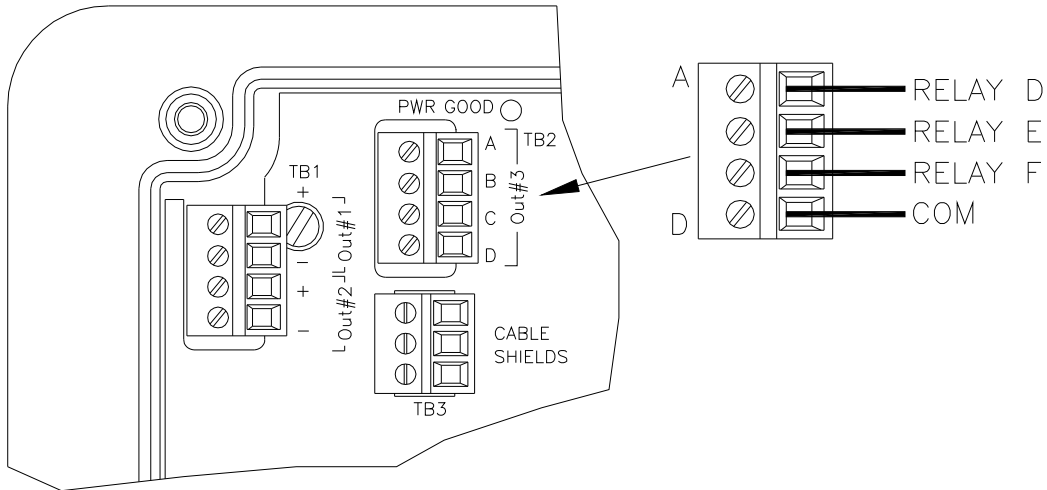

Figure 11 - Optional Relay Board Wiring

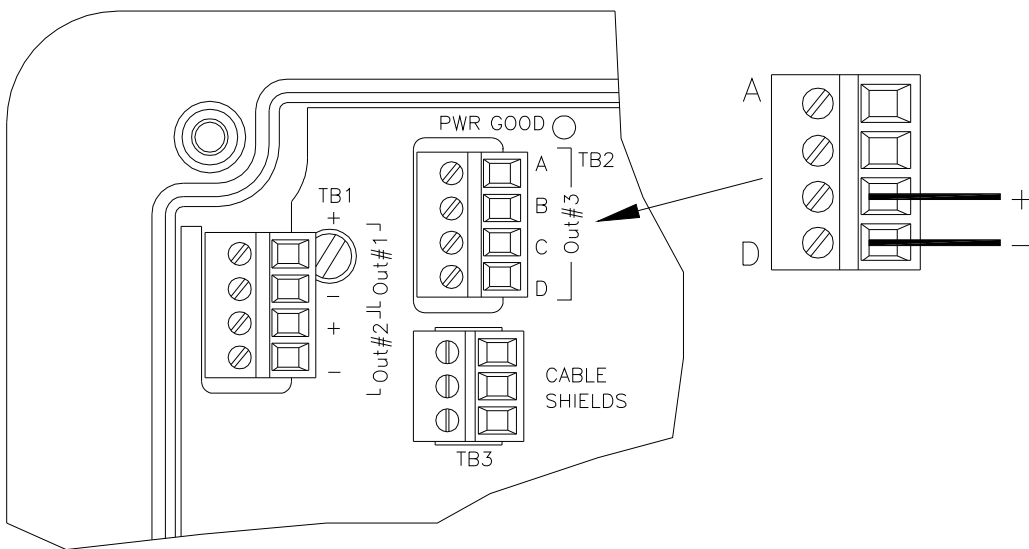

Figure 12 - Optional Analog Output Wiring

3.3 Chemistry Module Power Connection

The chemistry module power requirements are either 120 VAC or 220 VAC. Power connections are made at the terminals shown in Figure 13, below.

Note that the “Hot” or “L1” connection for AC power is made to a terminal beneath the fuse lever. Pull up the fuse lever to access the terminal screw for this connection.

Note that the analog outputs and relays are wired directly to the monitor unit in accordance with Figure 11 and Figure 12.

Note: Make sure the jumper is installed between terminals 10 & 11 on transmitter.

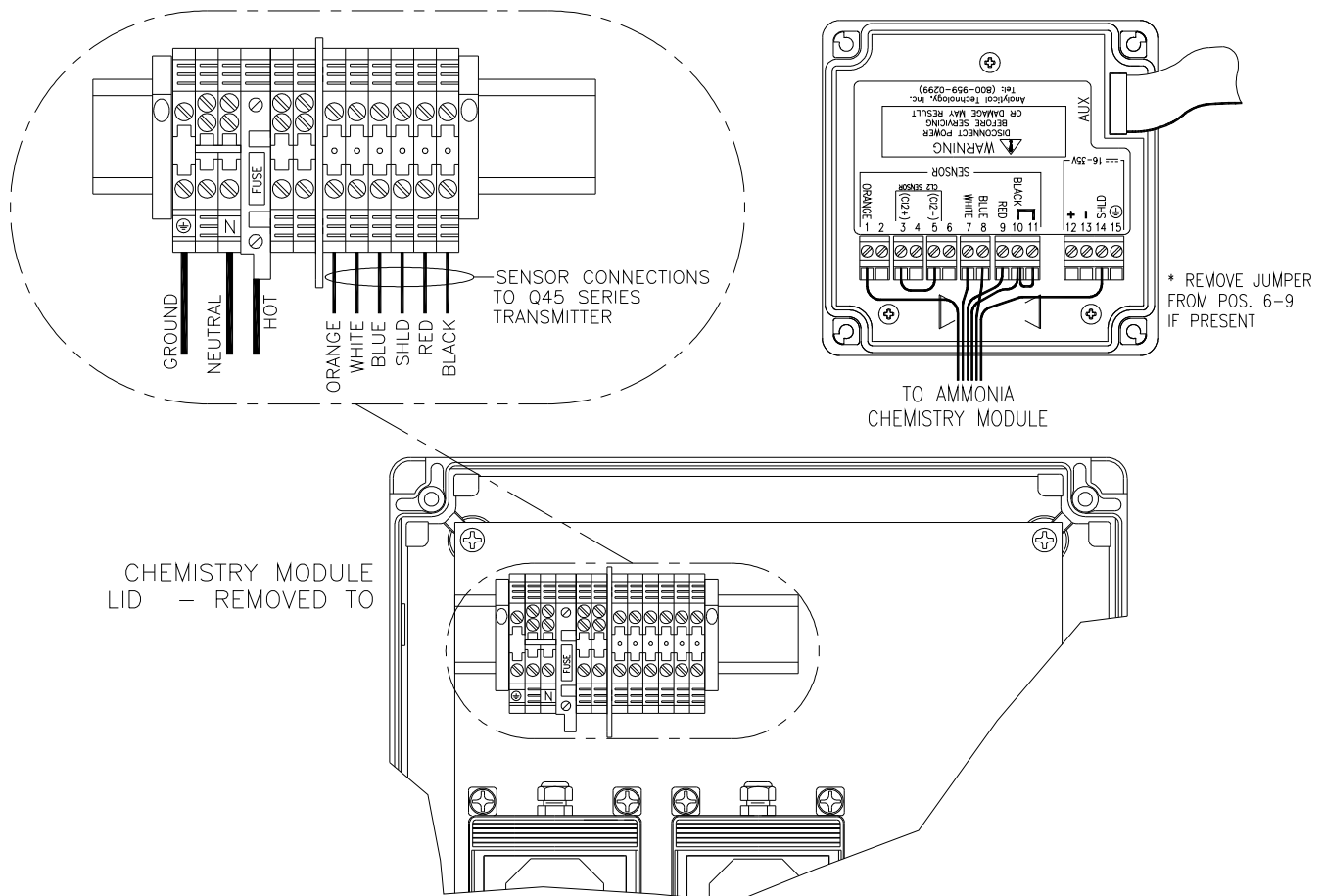

Figure 13 - Electrical Connections, separated System

Part 4 – Chemistry System Assy

4.1 Chemistry Module

The chemistry module is the heart of the ammonia monitor. Inside this module are the pumps, flow cell, and sensor element required to make an accurate ammonia measurement.

Ammonia measurement in the chemistry module is done by pumping a small amount of sample out of the filter assembly, mixing the sample with chemical reagents to convert ammonia into monochloramine. A second chemical is injected shortly after the first to stop the reaction and maintain the reaction product in the monochloramine form.

In operation, sample flows to the filter assembly, where particulate is removed from the process. The sample pump draws the process water out of the filter assembly, while the reagent pumps draw the chemicals from the respective containers. The chemical and sample feed lines merge, causing the streams to mix, whereby the reaction that converts ammonia to monochloramine.

The reacted sample then moves to the low volume flow cell. A special combined chlorine sensor located in this flow cell measures the monochloramine concentration, providing a signal to the Q46N electronics module.

Reacted sample from the flow cell passes into the inlet filter assembly, where it is discharged to waste.

The chemistry module is factory assembled, and only requires the reagent feed tubes to be attached to the reagent containers. The ammonia sensor also must be “charged” before operation is possible.

4.2 Sensor Preparation

The sensor supplied with the Q46N is shipped dry. It will not operate until it is prepared by adding electrolyte and a membrane. Preparation of the sensor for operation must be done carefully. The procedure should be done by a qualified technician, and it should only be done when the system is ready for operation. Until then, it is best to leave the sensor in the condition in which it is received.

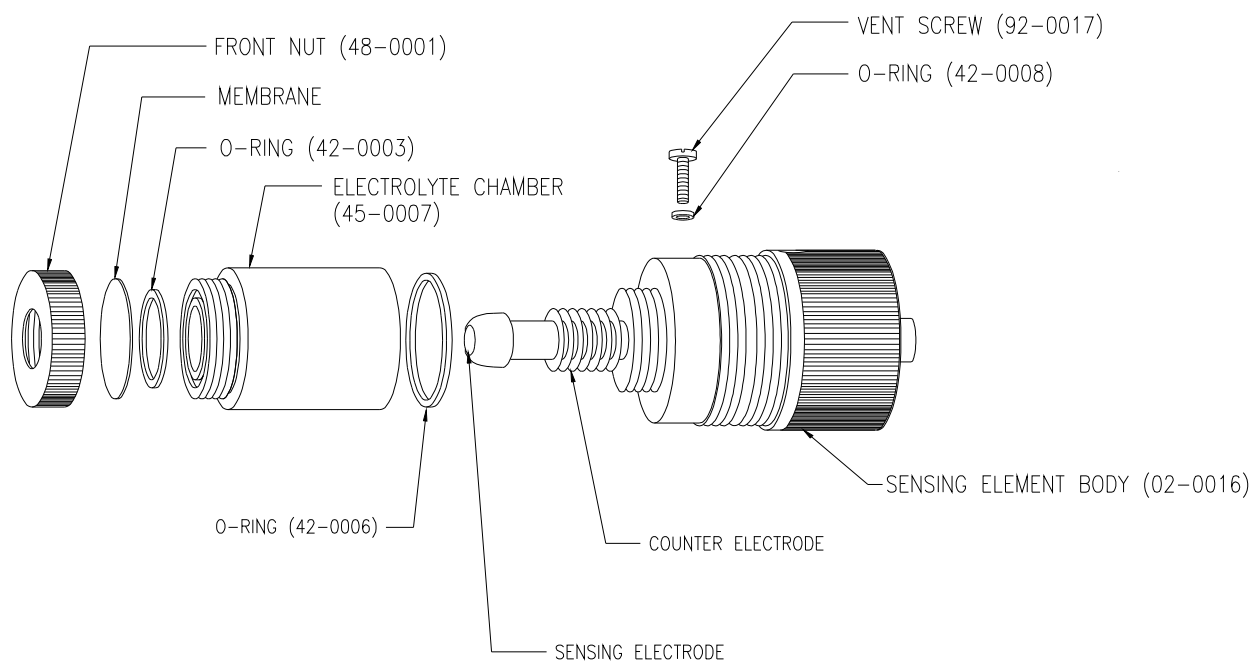

Figure 14 - Sensor Assembly

Follow the procedure below to prepare the sensor for operation:

1. Unscrew the electrolyte chamber from the assembled sensor and also remove the vent screw from the side of the sensor body.
2. Remove the front nut from the bottom of the chamber and discard the protective membrane. O-rings are contained in grooves on both the bottom and top of the chamber. Be sure that these o-rings remain in place.
3. From the package of membranes supplied with the sensor, place a new membrane into the front nut. **The membrane is white in color and is separated from other membranes by a light blue paper spacer.**
4. Screw the front nut on to the chamber until you feel the o-ring compress. Hand tight compression is all that is needed. Do not use tools to tighten. The membrane should be flat across the bottom of the chamber without wrinkles.
5. Fill the chamber with electrolyte until the level reaches the bottom of the internal threads.
6. Slowly screw the chamber onto the sensor body. A small amount of electrolyte will run out of the hole from which the vent screw was removed. Place a paper towel around the sensor to absorb the electrolyte overflow.

The electrolyte is harmless and will not irritate skin. Tighten the chamber until the o-ring at the top of the chamber is compressed. Once again, do not use tools to tighten.

7. Shake excess electrolyte from the fill hole on the side of the sensor and replace the vent screw.

The sensor is now ready for operation. The membrane should be stretched tightly across the tip of the sensor.

CAUTION: When handling the assembled sensor, do not set the sensor on its tip or damage to the membrane will result. Severe impacts on the tip of the sensor from dropping or other misuse may cause permanent damage to the sensor.

4.3 Sensor Installation

Once the sensor has been prepared for use, it is simply screwed into the sensor flowcell in the chemistry module. The flowcell is a clear circular block next to the peristaltic pumps in the chemistry system. A quick disconnect cable plugs into the back of the sensor.

NOTE: The sensor electrolyte chamber contains a small vent. This is the white dot located near the membrane end of the sensor. When installing the sensor in the flowcell, screw the sensor all the way in, and then unscrew it enough so that you see the white dot is at the top of the flowcell. This vent must be facing UP when the sensor is operating.

4.4 Reagent Preparation

The Q46N requires two reagents for normal operation. These are designated Reagent A and Reagent B. These reagents must be mixed on site and are stable for only about 2 months after mixing. One gallon of each will operate the system for approximately 45 days.

Reagent A

This reagent is a mixture of bleach, distilled water, a buffer (09-0057), and a reagent stabilizer (09-0058). You will need to purchase a bottle of Clorox bleach from a local market. The buffer and stabilizer are supplied by ATI in containers suitable for mixing one gallon.

Two gallon bottles are supplied, one marked Reagent A and one marked Reagent B. Add ½ gallon of distilled (or deionized) water to the bottle marked Reagent A and then add the container of the 09-0058 reagent stabilizer. Swirl the container to mix the stabilizer and then allow the container to sit for at least one hour. The stabilizer requires time to completely dissolve. Warming the distilled water will speed up the time required to dissolve the stabilizer

After the stabilizer has dissolved, add 600-650 cc of Clorox bleach (or any 5-6% sodium hypochlorite solution). Add additional distilled water until the liquid level is just below the neck of the bottle. Finally, add the container of 09-0057 buffer. Cap the bottle and invert a few time to mix. The mixture is now ready for use.

Place the reagent pickup assembly into the mouth of the bottle and connect the pickup tube to the proper inlet port on the bottom of the chemistry module.

Regent B

This reagent is a hydrogen peroxide solution. A 500 cc bottle of 27% peroxide is supplied. This must be diluted to one gallon for use.

Take bottle marked Reagent B and fill it half way with distilled water. Then carefully add 150-160 cc of of the peroxide concentrate into the bottle. Fill the bottle to the neck with distilled water. This reagent is ready immediately.

Place the reagent pickup assembly into the mouth of the bottle and connect the pickup tube to the proper inlet port on the bottom of the chemistry module.

CAUTION: Hydrogen peroxide solutions at 27% are hazardous. Avoid all contact with skin and eyes. Severe burns can result. Use protective gloves and eyewear when mixing Reagent B. Once diluted to one gallon, this solution is much less hazardous, having a concentration similar to that of peroxide sold in drug stores for disinfection of small cuts and scrapes.

Make special note of the need for protective gloves when handling new bottles of 27% peroxide. These bottles are often shipped in sealed plastic bags, and peroxide residue may be present on the outside surface of the bottle. It is a good idea to simply rinse the outside of the unopened bottle with tap water prior to handling the bottle without protective gloves.

Please note also that skin contact with the concentrated peroxide solution should be rinsed immediately. Even after rinsing, you will find that the contacted skin has been bleached (will turn white). This is a temporary situation, and your skin will return to normal after a few hours. There is no permanent damage from this brief contact.

4.5 Reagent Connections

Two reagent pickup assemblies Figure 15 are supplied for connection of reagents A and B to the chemistry system. On the bottom of the enclosure are two panel-mount connectors. These connectors are designed to mate with the leur fittings supplied with the pickup assemblies. Connect Reagent A to the fitting with the (BLUE) trim ring and Reagent B to the fitting with the (WHITE) trim ring. Reversing these connections will do no damage, but the unit will not measure ammonia correctly if they are reversed.

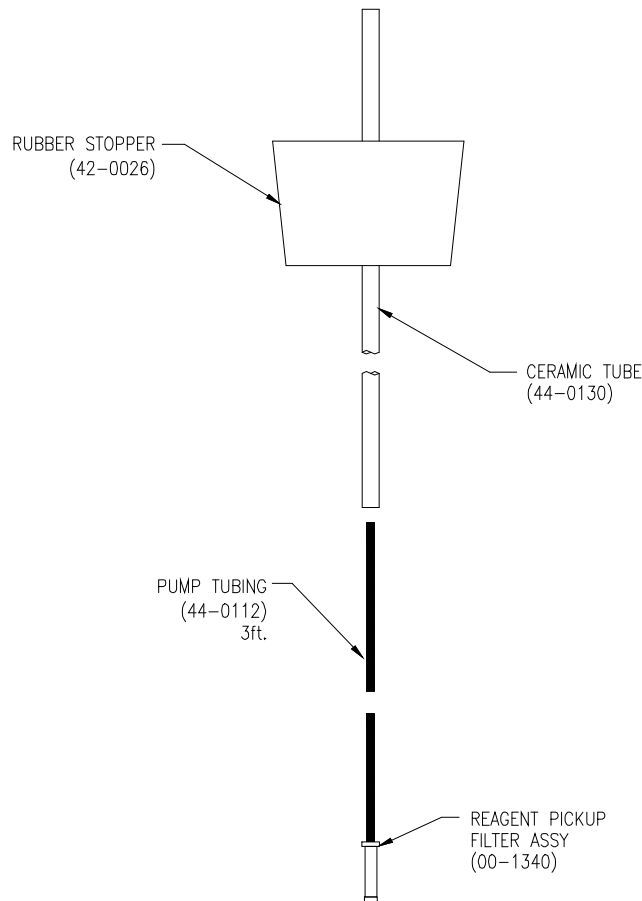

Figure 15 - Reagent Pickup Assembly

4.6 Reagent Bottle Holders

Two reagent bottle holders are supplied with the free ammonia monitor. These brackets should be mounted below the chemistry system with enough clearance so that the reagent bottles can be inserted and removed easily. The reagent pickup assemblies described in section 4.5 above are inserted into the reagent bottles once the reagent has been mixed. Figure 16 provides dimensions for mounting these brackets.

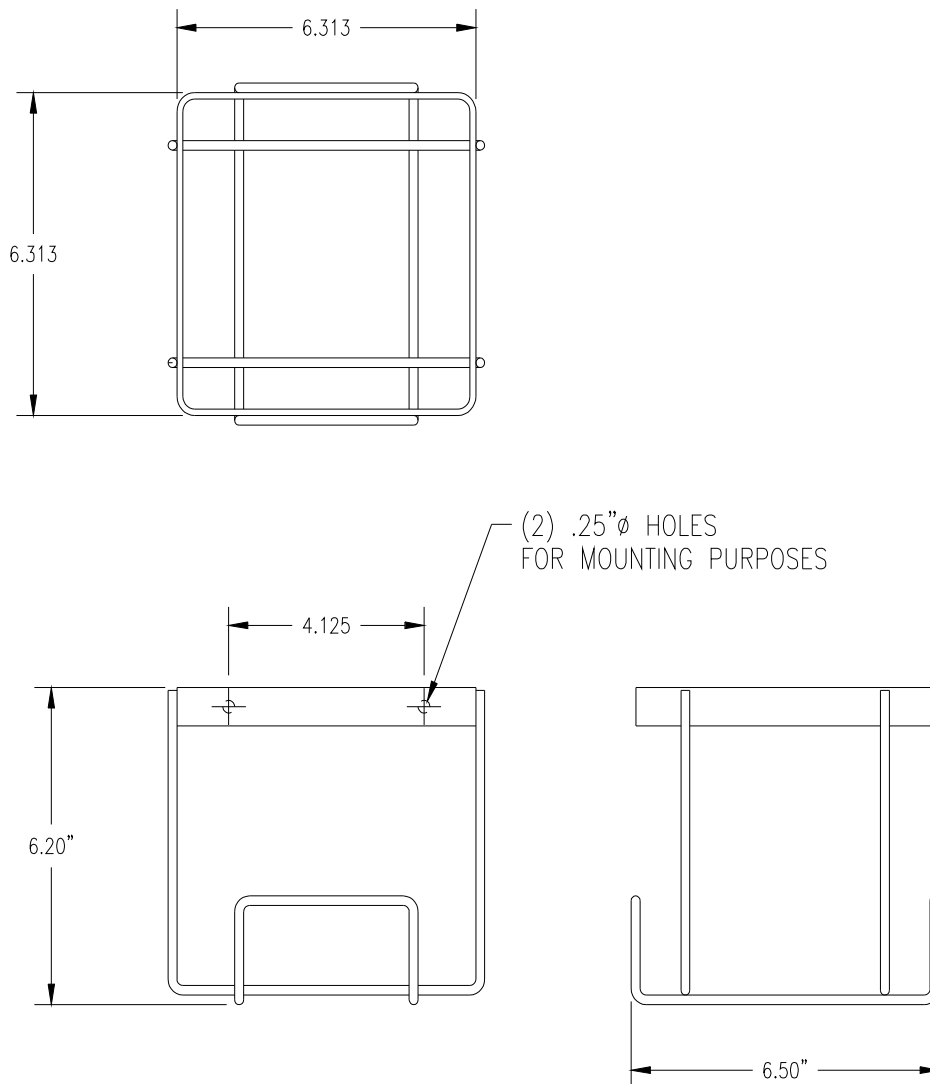

Figure 16 - Reagent Bottle Holder

4.7 Inlet Filter Assembly

A PVC block mounted on the side of the chemistry module is where sample inlet and drain connections are made. Tubing fittings and the sample selector valve assembly at the top of the filter holder are not installed when shipped to avoid transit damage. These items must be installed after the enclosure has been mounted to the wall. Figure 17 shows the assembly of the filter block components, which are supplied with other spare parts.

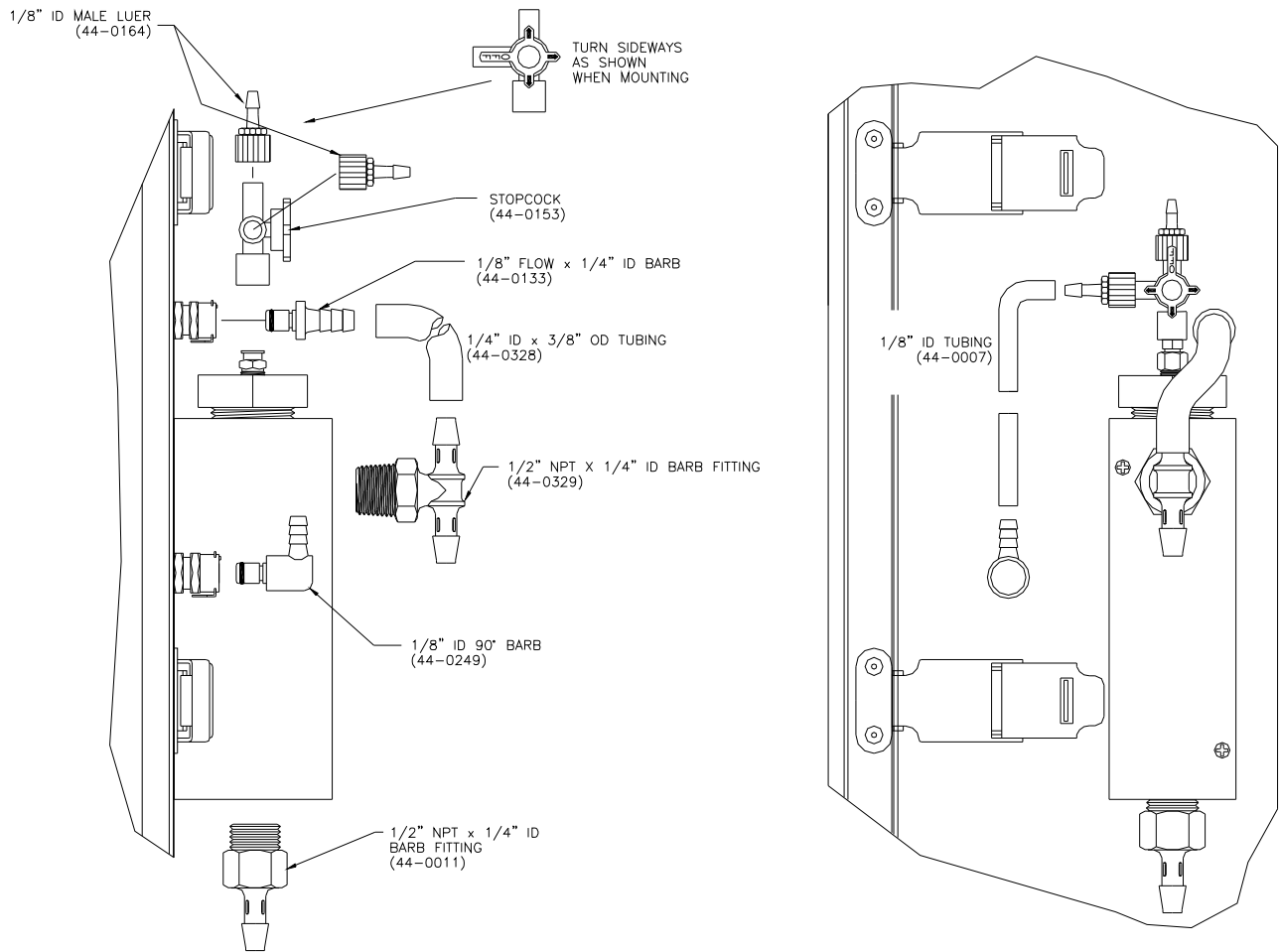

Figure 17 - Customer Inlet Assembly

Part 5 – Configuration

5.1 User Interface

The user interface for the Q46 Series instrument consists of a custom display and a membrane keypad. All functions are accessed from this user interface (no internal jumpers, pots, etc.).

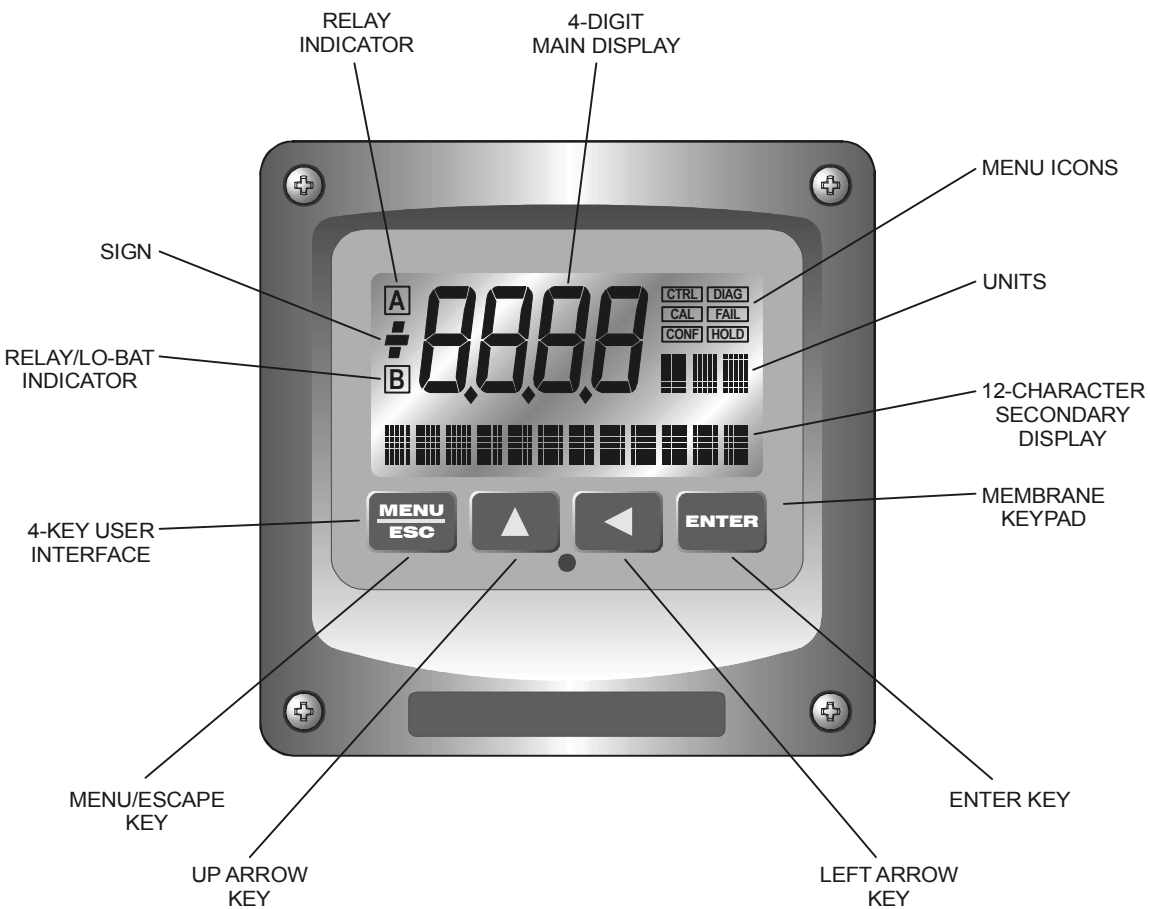

Figure 18 - User Interface

5.11 Keys

All user configurations occur through the use of four membrane keys. These keys are used as follows:

- | | |
|---------------------|---|
| MENU/ESC | To scroll through the menu section headers or to escape from anywhere in software. The escape sequence allows the user to back out of any changes in a logical manner. Using the escape key aborts all changes to the current screen and backs the user out one level in the software tree. The manual will refer to this key as either MENU or ESC, depending upon its particular function. In the battery-powered version of the Q46, this is also the ON button. |
| UP (arrow) | To scroll through individual list or display items and to change number values. |
| LEFT (arrow) | To move the cursor from right to left during changes to a number value. |
| ENTER | To select a menu section or list item for change and to store any change. |

5.12 Display

The large custom display provides clear information for general measurement use and user configuration. There are three main areas of the display: the main parameter display, the secondary message line, and the icon area.

- | | |
|-----------------------|--|
| Main Parameter | During normal operation, the main parameter display indicates the present process input with sign and units. This main display may be configured to display any of the main measurements that the system provides. During configuration, this area displays other useful set-up information to the user. |
|-----------------------|--|

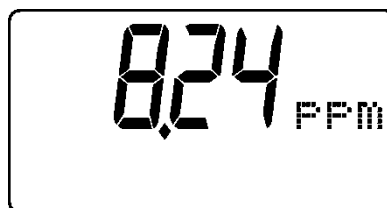

Lower Line

During normal operation, the lower line of the display indicates user-selected secondary measurements that the system is making. This also includes calibration data from the last calibration sequence and the transmitter model number and software version. During configuration, the lower line displays menu items and set-up prompts to the user. Finally, the lower line will display error messages when necessary. For a description of all display messages, refer to Section 10.5.



Icon Area

The icon area contains display icons that assist the user in set-up and indicate important states of system functions. The CAL, CTRL, CONFIG, and DIAG icons are used to tell the user what branch of the software tree the user is in while scrolling through the menu items. This improves software map navigation dramatically. Upon entry into a menu, the title is displayed (such as CAL), and then the title disappears to make way for the actual menu item. However, the icon stays on.



HOLD

The HOLD icon indicates that the current output of the transmitter has been put into output hold. In this case, the output is locked to the last input value measured when the HOLD function was entered. HOLD values are retained even if the unit power is cycled.

FAIL

The FAIL icon indicates that the system diagnostic function has detected a problem that requires immediate attention. This icon is automatically cleared once the problem has been resolved.

Relay Area A/B

The relay area contains two icons that indicate the state of the system relays (if the relay card is installed). Relay C is normally configured for FAIL indication, so it is only displayed on the lower MEASURE display line.

**5.2 Software**

The software of the Q46H is organized in an easy to follow menu-based system. All user settings are organized under five menu sections: Measure, Calibration [CAL], Configuration [CONFIG], Control [CONTROL] and Diagnostics [DIAG].

Note: The default Measure Menu is display-only and has no menu icon.

5.2.1 Software Navigation

Within the CAL, CONFIG, CONTROL, and DIAG menu sections is a list of selectable items. Once a menu section (such as CONFIG) has been selected with the MENU key, the user can access the item list in this section by pressing either the ENTER key or the UP arrow key. The list items can then be scrolled through using the UP arrow key. Once the last item is reached, the list wraps around and the first list item is shown again. The items in the menu sections are organized such that more frequently used functions are first, while more permanent function settings are later in the list. See Figure 19 for a visual description of the software.

Each list item allows a change to a stored system variable. List items are designed in one of two forms: simple single variable, or multiple variable sequences. In the single variable format, the user can quickly modify one parameter - for example, changing temperature display units from °F to °C. In the multiple variable sequence, variables are changed as the result of some process. For example, the calibration of ammonia generally requires more than one piece of information to be entered. The majority of the menu items in the software consist of the single variable format type.

Any data that may be changed will be flashing. This flashing indicates user entry mode and is initiated by pressing the ENTER key. The UP arrow key will increase a flashing digit from 0 to 9. The LEFT arrow key moves the flashing digit from right to left. Once the change has been completed, pressing ENTER again stores the variable and stops the flashing. Pressing ESC aborts the change and also exits user entry mode.

The starting (default) screen is always the Measure Menu. The UP arrow key is used to select the desired display. From anywhere in this section the user can press the MENU key to select one of the four Menu Sections.

The UP arrow icon next to all list items on the display is a reminder to scroll through the list using the UP arrow key.

To select a list item for modification, first select the proper menu with the MENU key. Scroll to the list item with the UP arrow key and then press the ENTER key. This tells the system that the user wishes to perform a change on that item. For single item type screens, once the user presses the ENTER key, part or all of the variable will begin to flash, indicating that the user may modify that variable using the arrow keys. However, if the instrument is locked, the transmitter will display the message **Locked!** and will not enter user entry mode. The instrument must be unlocked by entering the proper code value to allow authorized changes to user entered values. Once the variable has been reset, pressing the ENTER key again causes the change to be stored and the flashing to stop. The message **Accepted!** will be displayed if the change is within pre-defined variable limits. If the user decides not to modify the value after it has already been partially changed, pressing the ESC key aborts the modification and returns the entry to its original stored value.

In a menu item which is a multiple variable sequence type, once the ENTER key is pressed there may be several prompts and sequences that are run to complete the modification. The ESC key can always be used to abort the sequence without changing any stored variables.

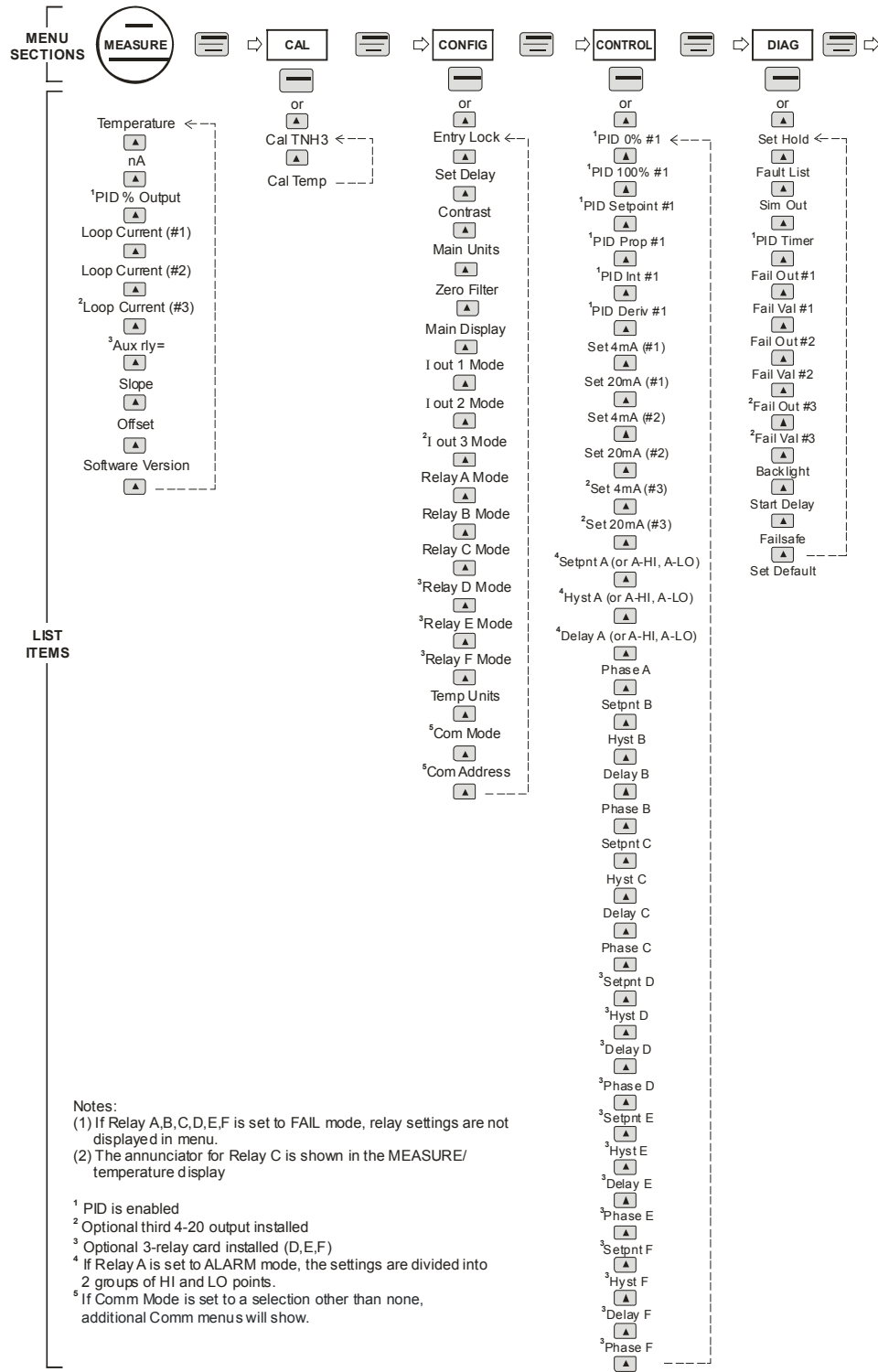

Figure 19 - Software Map

5.22 Measure Menu [MEASURE]

The default menu for the system is the display-only menu MEASURE. This menu is a display-only measurement menu, and has no changeable list items. When left alone, the instrument will automatically return to this menu after approximately 30 minutes. While in the default menu, the UP arrow allows the user to scroll through the secondary variables on the lower line of the display. A brief description of these variables are as follows:

TRANSMITTER MEAS SCREENS:

25.7C	Temperature display can be displayed in C or F, depending on user selection. A small “m” on the left side indicates the transmitter has jumped to a manual 25C setting due to a failure with the temperature signal input.
100% 20.00 mA	PID Status screen (if enabled.) Shows the present controller output level on left and actual transmitter current on the right. The controller can be placed in manual by pressing and holding the ENTER key for 5 seconds until a small flashing “m” appears. The controller output can be adjusted up or down using the UP and LEFT arrow keys. To return to automatic operation, press and hold the ENTER key for 5 seconds and the “M” will disappear.
#1 4.00 mA	Transmitter output current # 1
#2 12.00 mA	Transmitter output current # 2
#3 20.00 mA	Analyzer output current # 3 (if option included.)
Aux relay= D,E,F	Auxiliary relay annunciators (if option included.)
32.0 nA	Raw sensor current. Useful for diagnosing problems.
Slope = 100%	Sensor output response vs. ideal calibration. This value updates after each calibration. As the sensor ages, the slope reading will decay indicating sensor aging. Useful for resolving sensor problems.
Offset = 0.0 nA	Sensor output current at a zero ppm input. This value updates after a zero-calibration has been performed. Useful for resolving sensor problems.
Q46N v4.01	Transmitter software version number.

Note: A display test (all segments ON) can be actuated by pressing and holding the ENTER key while viewing the model/version number on the lower line of the display.

The MEASURE screens are intended to be used as a very quick means of looking up critical values during operation or troubleshooting.

5.23 Calibration Menu [CAL]

The calibration menu contains items for frequent calibration of user parameters. There are four items in this list: Cal NH₃, Cal Temp, SetRange, and Cal Zero.

Cal NH₃ The ammonia calibration function allows the user to adjust the transmitter span reading to match a reference solution, or to set the sensor zero point. See Part 6 - Calibration for more details.

Cal Temp The temperature calibration function allows the user to adjust the offset of the temperature response by a small factor of ± 5 °C. The temperature input is factory calibrated to very high accuracy. However, long cable lengths and junction boxes may degrade the accuracy of the temperature measurement in some extreme situations. Therefore, this feature is provided as an adjustment. See Part 6 - Calibration for more details.

5.24 Configuration Menu [CONFIG]

The Configuration Menu contains all of the general user settings:

- Entry Lock** This function allows the user to lock out unauthorized tampering with instrument settings. All settings may be viewed while the instrument is locked, but they cannot be modified. The Entry Lock feature is a toggle-type setting; that is, entering the correct code will lock the transmitter and entering the correct code again will unlock it. The code is preset at a fixed value. Press ENTER to initiate user entry mode and the first digit will flash. Use arrow keys to modify value. **See Page 77 for the Q46N lock/unlock code.** Press ENTER to toggle lock setting once code is correct. Incorrect codes do not change state of lock condition.
- Set Delay** The delay function sets the amount of damping on the instrument. This function allows the user to apply a first order time delay function to the ammonia measurement. Both the display and the output value are affected by the degree of damping. Functions such as calibration are not affected. The calibration routines contain their own filtering and stability monitoring functions to minimize the calibration timing. Press ENTER to initiate user entry mode, and the value will flash. Use the arrow keys to modify value; range is 0.1 to 9.9 minutes. Press ENTER to store the new value.
- Contrast** This function sets the contrast level for the display. The custom display is designed with a wide temperature range, Super-Twist Nematic (STN) fluid.
- The STN display provides the highest possible contrast and widest viewing angle under all conditions. Contrast control of this type of display is generally not necessary, so contrast control is provided as a means for possible adjustment due to aging at extreme ranges. In addition, the display has an automatic temperature compensation network. Press ENTER to initiate user entry mode, and the value will flash. Use arrow keys to modify the value; range is 0 to 8 (0 being lightest). Press ENTER to update and store the new value.
- Main Units** This function allows the user to select either PPM or mg/l for the dissolved ammonia measurement.

- Zero Filter** This function forces the reading to zero when reading is below the entered value. For example, if the entered value were 0.0020 the display at 0-0019 would indicate 0.000. This feature is useful in blanking out zero noise.
- Main Display** This function allows the user to change the measurement in the primary display area. The user may select between ammonia, sensor temperature, or output current. Using this function, the user may choose to put temperature in the main display area and ammonia on the secondary, lower line of the display. Press ENTER to initiate user entry mode, and the entire value will flash. Use the UP arrow key to modify the desired display value. Press ENTER to store the new value.
- Com Mode** Sets digital communication mode of analyzer. Optional digital communication card must be plugged into the power supply slot for this function to work. Press ENTER to initiate user entry mode, and the entire value will flash. Use the UP arrow key to modify the desired value; selections include 1-None, 2- P-DP for Profibus DP, 3 – Modbus, 4 – Ethernet IP. Press ENTER to store the new value.
- Com Address** Sets bus address for digital communication mode of analyzer. Optional digital communication card must be plugged into the power supply slot for this function to work.
- Press ENTER to initiate user entry mode, and the entire value will flash. Use the UP arrow key to modify the desired value. Range is 1-125. Press ENTER to store the new value.
- Iout#1 Mode** This function sets analog output #1 to either track ammonia (default) or enables the PID controller to operate on the ammonia input. Press ENTER to initiate user entry mode, and the entire value will flash. Use the UP arrow key to modify the desired value; selections include 1-ppm for ammonia tracking or 2-PID for ammonia PID control. Press ENTER to store the new value.

lout#2 Mode This function sets analog output #2 for either temperature (default) or ammonia. Press ENTER to initiate user entry mode, and the entire value will flash. Use the UP arrow key to modify the desired value; selections include 1-C/F for temperature or 2-ppm for ammonia. Press ENTER to store the new value.

***lout#3 Mode** **OPTIONAL.** This function sets analog output #3 for either ammonia or temperature. Press ENTER to initiate user entry mode, and the entire value will flash. Use the UP arrow key to modify the desired value; selections include 1-C/F for temperature, 2-ppm for ammonia. Press ENTER to store the new value.

Rly A Mode Relay A can be used in three different ways: as a setpoint control, as a fail alarm, or as a HI-LO alarm band. The three settings for Rly A Mode are **CON**, **FAIL** and **AL**.

The **CON** setting enables normal control operation for Relay A, with settings for setpoint, hysteresis, delay and phasing appearing in the CONFIG menu automatically. See Figure 20 for further details.

The **FAIL** setting enables the fail alarm mode for Relay A. Relay A will then trip on any condition that causes the FAIL icon to be displayed on the LCD. Using this mode allows the User to send alarm indications to other remote devices.

The **AL** setting allows two setpoints to be selected for the same relay, producing a HI-LO alarm band. In this mode, Relay A will trip inside or outside of the band, depending upon the Phase selected. See Figure 21 for further details.

Relay B Mode Relay B can be used in a number of ways: as a setpoint control, or as an alarm. The two settings for Relay B Mode are **CON** and **FAIL**.

The **CON** setting enables normal setpoint operation for Relay B. Relay B then operates identically to Relay A, with settings for setpoint, hysteresis, delay and phasing appearing in the CONFIG menu automatically. See Figure 20 for details.

The **FAIL** setting enables the fail alarm mode for Relay B. Relay B will then trip on any condition that causes the FAIL icon to be displayed on the LCD. Using this mode allows the User to send alarm indications to other remote devices. See Figure 21 for details.

Relay D Mode**Relay E Mode*****Relay F Mode**

OPTIONAL. Relays D, E, and F can be used in two ways: as a setpoint control, or as an alarm. The two settings for Relay B Mode are **CON** and **FAIL**.

The **CON** setting enables normal setpoint operation for Relay B. Relay B then operates identically to Relay A, with settings for setpoint, hysteresis, delay and phasing appearing in the CONFIG menu automatically. See Figure 20 for details.

Temp Units

This function sets the display units for temperature measurement. Press ENTER to initiate user entry mode, and the entire value will flash. Use the UP arrow key to modify the desired display value. The choices are °F and °C. Press ENTER to store the new value.

5.25 Control Menu [CONTROL]

The Control Menu contains all of the output control user settings:

NOTE: PID display do not appear unless lout#1 is configured for PID function

Set 4 mA

Set 20 mA

[lout1=ammonia]

These functions set the main 4 and 20 mA current loop output points for the transmitter. The units displayed depend on the selection made in the CONFIG menu for lout #1 Mode. Also, when the Relay Option Board is installed, the units will also display **#1 or #2** – since there are actually two analog outputs present in this version.

The value stored for the 4 mA point may be higher or lower than the value stored for the 20 mA point. The entry values are limited to values within the range specified in “Set Range”, and the 4 mA and the 20 mA point must be separated by at least 1% of this range Use the LEFT arrow key to select the first digit to be modified. Then use the UP and LEFT arrow keys to select the desired numerical value. Press ENTER to store the new value.

Set PID 0%

Set PID 100%

[lout1=PID]

If the PID is enabled, this function sets the minimum and maximum controller end points. Unlike the standard 4-20 mA output, the controller does not “scale” output values across the endpoints. Rather, the endpoints determine where the controller would normally force minimum or maximum output in an attempt to recover the setpoint (even though the controller can achieve 0% or 100% anywhere within the range.)

If the 0% point is lower than the 100% point, then the controller action will be “reverse” acting. That is, the output of the controller will increase if the measured value is less than the setpoint, and the output will decrease if the measured value is larger than the setpoint. Flipping the stored values in these points will reverse the action of the controller to “direct” mode.

The entry value is limited to a value within the range specified in “Set Range”, and the 0% and the 100% point must be separated by at least 1% of this range Use the LEFT arrow key to select the first digit to be modified. Then use the UP and LEFT arrow keys to select the desired numerical value. Press ENTER to store the new value.

PID Setpnt

[lout1=PID]

The measured value which the controller is attempting to maintain by adjusting output value. It is the nature of the PID controller that it never actually gets to the exact value and stops. The controller is continually making smaller and smaller adjustments as the measured value gets near the setpoint.

PID Prop

[lout1=PID]

Proportional gain factor. The proportional gain value is a multiplier on the controller error (difference between measured value and setpoint value.) Increasing this value will make the controller more responsive.

PID Int

[lout1=PID]

Integral is the number of “repeats-per-minute” of the action of the controller. It is the number of times per minute that the controller acts on the input error. At a setting of 2.0 rpm, there are two repeats every minute. If the integral is set to zero, a fixed offset value is added to the controller (manual reset.) Increasing this value will make the controller more responsive.

PID Deriv

[lout1=PID]

Derivative is a second order implementation of Integral, used to suppress “second-order” effects from process variables. These variables may include items like pumps or mixers that may have minor impacts on the measured value. The derivative factor is rarely used in water treatment process, and therefore, it is best in most cases to leave it at the default value. Increasing this value will make the controller more responsive.

Set 4 mA #2**Set 20 mA #2**

[temp/ammonia]

These functions set the second 4 mA and 20 mA current loop output points for the transmitter. The output may be set to track temperature (default) or ammonia. The values stored for the 4 mA point may be higher or lower than the value stored for the 20 mA point.

The entry value is limited to a value between 0 and 55 °C if it is set for temperature or within the range specified in “Set Range” if the output is set to track ammonia. The 4 mA and the 20 mA point must be at least 20 units away from each other. Press ENTER to initiate user entry mode, and the value will flash. Use arrow keys to modify value. Press ENTER to store the new value.

Set 4 mA #3**Set 20 mA #3**

[temp/ppm]

OPTIONAL. These functions set the optional third 4 mA and 20 mA current loop output points for the analyzer. The output may be set to track temperature (default) or PPM ammonia. The values stored for the 4 mA point may be higher or lower than the value stored for the 20 mA point.

The entry value is limited to a value between 0 and 55 °C if it is set for temperature, within the range specified in “Set Range” if the output is set to set to track ammonia. The 4 mA and the 20 mA point must be at least 20 units away from each other. Press ENTER to initiate user entry mode, and the value will flash. Use arrow keys to modify value. Press ENTER to store the new value.

A Setpoint

This function establishes the trip point for relay A. The entry value is limited to a value within the range specified in “SetRange”. Use the LEFT arrow key to select the first digit to be modified. Then use the UP and LEFT arrow keys to select the desired numerical value. Press ENTER to store the new value.

A Hysteresis

This function establishes the hysteresis, or “deadband”, for Relay A. Hysteresis is most often used to control relay chattering; however, it may also be used in control schemes to separate the ON/OFF trip points of the relay. Press ENTER to initiate user entry mode, and the value will flash. Use the arrow keys to modify value. Press ENTER to store the new value.

A Delay

This function places an additional amount of time delay on the trip point for relay A. This delay is in addition to the main delay setting for the controller. The entry value is limited to a value between 0 and 999 seconds. Press ENTER to initiate user entry mode, and the value will flash. Use arrow keys to modify value; range is 0 to 999 seconds. Press ENTER to store the new value.

A Phasing

This function establishes the direction of the relay trip. When phase is HI, the relay operates in a direct mode. Therefore, the relay energizes and the LCD indicator illuminates when the ammonia value **exceeds** the setpoint. When the phase is LO, the relay energizes and the LCD indicator illuminates when the ammonia level drops **below** the setpoint. The failsafe setting does have an impact on this logic. The description here assumes the failsafe setting is OFF. Press ENTER to initiate user entry mode, and the entire value will flash. Use the UP arrow key to modify the desired value; selections include **HI** for direct operation or **LO** for reverse operation. Press ENTER to store the new value.

See Figure 20 - Control Relay Example below for a visual description of a typical control relay application.

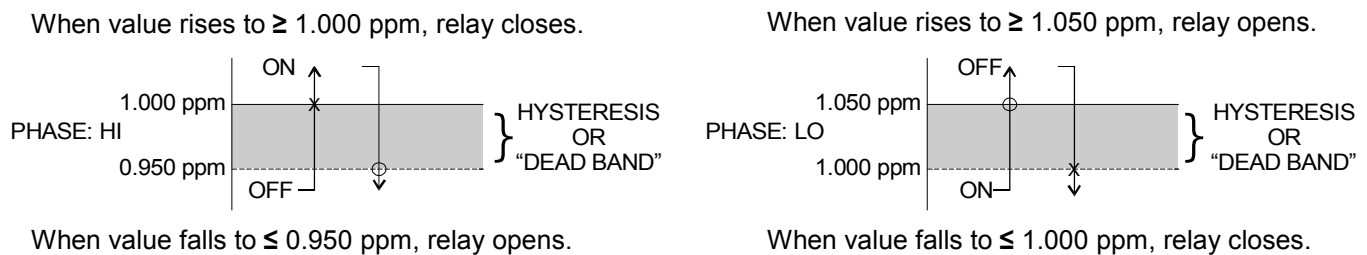

Settings:

Setpoint: 1.000 ppm Hyst: 0.050
 Delay: 000 Failsafe: OFF

Figure 20 - Control Relay Example

- *Setpnt A-HI
- *Hyst A-HI
- *Delay A-HI
- *Setpnt A-LO
- *Hyst A-LO
- *Delay A-LO

If Relay A Mode is set to Alarm Mode, **AL**, then the following settings will appear in the Config Menu list automatically. In this mode, two setpoints can be selected on the same relay, to create an alarm band. Phase HI selection causes the relay to energize outside of the band, and Phase LO causes the relay to energize inside of the band. This feature enables one relay to be used as a control relay while the other is used as a HI-LO Alarm relay at the same time. Setpoint A-LO must be set lower than Setpoint A-HI. When AL mode is first selected, Setpoint A-LO is defaulted to 0.

Figure 21 is a visual description of a typical alarm relay application.

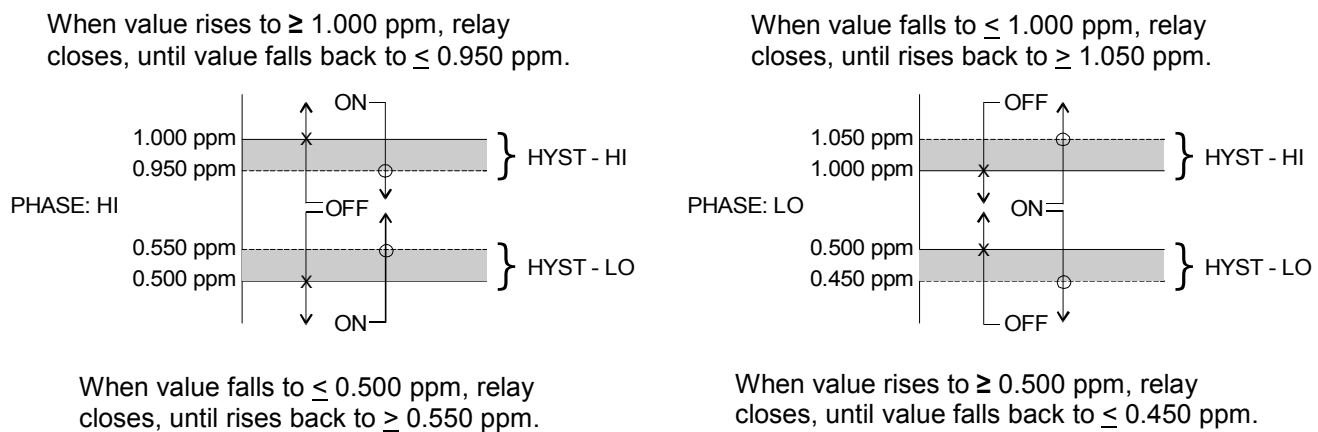

Settings:

Setpoint A-HI: 1.000 ppm	Setpoint A-LO: .500 ppm
Hyst A-HI: 0.050	Hyst A-LO: .050
Delay A-HI: 000	Delay A-LO: 000

Figure 21 - Alarm Relay Examples

- *B Setpoint
- *B Hysteresis
- *B Delay
- *B Phasing

If Relay B Mode is set to **CON** (see **Relay B Mode**, page 40), then Relay B will function identically to Relay A CON mode described earlier. Relay B settings appear in the CONFIG menu list automatically.

5.26 Diagnostics Menu [DIAG]

The diagnostics menu contains all of the user settings that are specific to the system diagnostic functions, as well as functions that aid in troubleshooting application problems.

Set Hold

The Set Hold function locks the current loop output values on the present process value, and halts operation of the PID controller. This function can be used prior to calibration, or when removing the sensor from the process, to hold the output in a known state. Once HOLD is released, the outputs return to their normal state of following the process input. The transfer out of HOLD is bumpless on the both analog outputs - that is, the transfer occurs in a smooth manner rather than as an abrupt change. An icon on the display indicates the HOLD state, and the HOLD state is retained even if power is cycled. Press ENTER to initiate user entry mode, and entire value will flash. Use the UP arrow key to modify the desired value, selections are **ON** for engaging the HOLD function, and **OFF** to disengage the function. Press ENTER to store the new value.

Note: When the Relay Option Board is installed, the Set Hold function holds BOTH current levels, as well as ALL relay settings.

The Set Hold function can also hold at an output value specified by the user. To customize the hold value, first turn the HOLD function on. Press the ESC key to go to the DIAG Menu and scroll to Sim Output using the UP arrow key. Press ENTER. Follow the instructions under Sim Output (see following page).

Fault List

The Fault List screen is a read-only screen that allows the user to display the cause of the highest priority failure. The screen indicates the number of faults present in the system and a message detailing the highest priority fault present. Note that some faults can result in multiple displayed failures due to the high number of internal tests occurring. As faults are corrected, they are immediately cleared.

Faults are not stored; therefore, they are immediately removed if power is cycled. If the problem causing the faults still exists, however, faults will be displayed again after power is re-applied and a period of time elapses during which the diagnostic system re-detects them. The exception to this rule is the calibration failure. When a calibration fails, no corrupt data is stored. Therefore, the system continues to function normally on the data that was present before the calibration was attempted.

After 30 minutes or if power to the transmitter is cycled, the failure for calibration will be cleared until calibration is attempted again. If the problem still exists, the calibration failure will re-occur. Press ENTER to initiate view of the highest priority failure. The display will automatically return to normal after a few seconds.

PID Timer

This function sets a timer to monitor the amount of time the PID controller remains at 0% or 100%. This function only appears if the PID controller is enabled. If the timer is set to 0000, the feature is effectively disabled. If the timer value is set to any number other zero, a FAIL condition will occur if the PID controller remains at 0% or 100% for the timer value. If one of the relays is set to FAIL mode, this failure condition can be signaled by a changing relay contact.

Press ENTER to initiate user entry mode, and the entire value will flash. Use the UP arrow key to modify desired value; range of value is 0-9999 seconds. Press ENTER to store the new value.

Sim Out

The Sim Out function allows the user to simulate the ammonia level of the instrument in the user selected display range. The user enters a ppm value directly onto the screen, and the output responds as if it were actually receiving the signal from the sensor. This allows the user to check the function of attached monitoring equipment during set-up or troubleshooting. Escaping this screen returns the unit to normal operation. Press ENTER to initiate the user entry mode, and the right-most digit of the value will flash. Use arrow keys to modify desired value.

The starting display value will be the last read value of the input. The output will be under control of the SIM screen until the ESC key is pressed.

Note: If the HOLD function is engaged before the Sim Output function is engaged, the simulated output will remain the same even when the ESC key is pressed. Disengage the HOLD function to return to normal output.

Fail Out #1

This function enables the user to define a specified value that the main current output will go to under fault conditions. When the Relay Option Board is installed, the display will read **Fail Out #1**. When enabled to **ON**, the output may be forced to the current value set in **Fail Val** (next item.) With the Fail Out setting of **ON**, and a Fail Val setting of 6.5 mA, any alarm condition will cause the current loop output to drop outside the normal operating range to exactly 6.5 mA, indicating a system failure that requires attention.

Press ENTER to initiate user entry mode, and the entire value will flash. Use the UP arrow key to modify desired value; selections are **ON**, **OFF**. Press ENTER to store the new value.

Fail Val #1

Sets the output failure value for lout#1. When **Fail Out** above is set to **ON**, this function sets value of the current loop under a FAIL condition. When the Relay Option Board is installed, the display will read **Fail Out #1**. The output may be forced to any current value between 4-20 mA.

Press ENTER to initiate user entry mode, and the entire value will flash. Use the UP arrow key to modify desired value; selections are between **4mA**, and **20mA**. Press ENTER to store the new value.

Fail Out #2

This function sets the fail-mode of current loop output #2 under a FAIL condition. The settings and operation are identical to Fail Out for output #1.

Fail Val #2

This function sets the value of current loop output #2 under a FAIL condition. The settings and operation are identical to Fail Out for output #1.

- *Fail Out #3** **OPTIONAL.** This function sets the fail-mode of current loop output #3 under a FAIL condition. The settings and operation are identical to Fail Out for output #1.
- *Fail Val #3** **OPTIONAL.** This function sets the value of current loop output #3 under a FAIL condition. The settings and operation are identical to Fail Out for output #1.
- Backlight** This function has three options. **ON** – On all the time, **OFF** – Off all the time, **AL** – Alarm (Default). This function flashes the backlight on and off whenever the Fail icon is displayed.
- Failsafe** This function allows the user to set the optional system relays to a failsafe condition. In a failsafe condition, the relay logic is reversed so that the relay is electrically energized in a normal operating state. By doing this, the relay will not only change state when, for example, an ammonia limit is exceeded, but also when power is lost to the controller.
- When failsafe is selected to be ON, the normally-open contacts of the relay will be closed during normal operation. In an attempt to make this configuration less confusing, the LCD icon logic is reversed with this setting, and the icon is OFF under this normal condition. Therefore, when the trip condition occurs, the closed N.O. contacts will be opened (relay de-energized), and the LCD icon will illuminate. In addition, a power fail would also cause the same contacts to open.
- Start Delay** This function is designed to minimize control or alarm issues arising from temporary power loss. When power goes down, the monitor records the analog output values and the status of relays and PID functions. When power is restored, the analog values and relays will be held at the pre-power loss values for a defined period of time. This “start delay” may be programmed for periods from 0-9.9 minutes. This function is set to 0.0 minutes by default and must be activated by the user if desired by setting a positive time value

Set Default

The Set Default function allows the user to return the instrument back to factory default data for all user settings. It is intended to be used as a last resort troubleshooting procedure. All user settings are returned to the original factory values. Hidden factory calibration data remains unchanged. Press ENTER to initiate user entry mode and the value **NO** will flash. Use the UP arrow key to modify value to **YES** and press ENTER to reload defaults.

Part 6 – Calibration

6.1 Ammonia Calibration

Once power is applied, the sensor must be given time to stabilize. This is best done by operating the monitor on tap water for at least 4 hours. If the monitor is to be used for monitoring this type of sample, simply connect the sample to the filter assembly and turn on the flow. If the application is wastewater, it is best to use a bucket of tap water and install a temporary piece of tubing to allow the sample pump to pull water from the bucket during stabilization. The drainage from the sensor is pumped back into the filter assembly so the inlet port to this assembly should be blocked off by closing your inlet sample valve, or a piece of tubing should be installed temporarily to drain away the waste from the chemistry system during stabilization.

6.11 Ammonia ZeroCal

In order to properly zero an ammonia system, it is necessary to run ammonia free water through the system for at least 30 minutes. **This should be done only after the monitor has been running for at least 4 hours to allow complete stabilization.**

The steps below assume that the sensor has been prepared in accordance with section 4.2, Sensor Assembly, earlier in this manual. It also assumes that the system has been running for 4 hours prior to attempting to zero the unit.

1. Locate the 3-way valve at the top of the inlet filter assembly and connect the piece of silicon tubing supplied with the unit to the open fitting. The OFF position of the valve handle will be pointing toward this fitting.
2. Place the other end of the tubing into a gallon bottle of spring water or distilled water. **Spring water is preferred as it provides some buffering capacity so that the treated sample will more closely approximate normal sample water.** Turn the 3-way valve so that the OFF indicator is pointing down toward the filter block. The sample pump will draw sample from this container into the chemistry system. Allow the unit to run for 30 minutes. The sample pump draws about 13 cc per minute of sample so you will need at least 400 cc of ammonia free water to complete the zero procedure.
3. Scroll to the CAL menu section using the MENU key and press ENTER or the UP arrow key. **Cal NH3** will then be displayed.

4. Press the ENTER key. The screen will display a flashing **1-Ref** for span calibration or a **2-Zer** for zero calibration. Using the UP arrow key, set for a **2-Zer** zero calibration and press ENTER.
5. The system now begins acquiring data for the sensor zero calibration value. As data is gathered, the units for sensor current in nanoamps (nA) and temperature may flash. Flashing units indicate that this parameter is unstable. The calibration data point acquisition will stop only when the data remains stable for a pre-determined amount of time. This can be overridden by pressing ENTER. If the data remains unstable for 10 minutes, the calibration will fail and the message **CalUnstable** will be displayed.
6. If accepted, the screen will display the message **PASS** with the new sensor zero reading (offset), then it will return to the main measurement display. If the calibration fails, a message indicating the cause of the failure will be displayed and the FAIL icon will be turned on. The range of acceptable value for sensor offset is -25nA to +25 nA. Should a FAIL occur, carefully inspect the sensor for a tear in the membrane. It will probably be necessary to rebuild the sensor as described in section 4.2, Sensor Assembly. Should the offset value remain high and result in calibration failures, review the Service section of this manual, and then contact the service dept. at ATI for further assistance.
7. Turn the 3-way valve back to the normal operating position.

The sensor zero offset value in nA from the last zero calibration is displayed on the lower line of the Default Menus for information purposes.

6.12 Ammonia SpanCal

Span calibration of the system must be done against a laboratory measurement on the same sample that the sensor is measuring. A sample should be collected from the inlet line feeding the flow cell and quickly analyzed for ammonia using a test kit. When calibrating, it is best to have a reasonably high concentration of ammonia in the system. A value higher than 1 PPM is preferred to reduce the errors that might be introduced through errors in the test kit measurement at low concentrations. The ammonia monitor may also be calibrated using a mixed ammonia standard if you have the facilities for preparing the standard.

Use the same sample inlet fitting and tube assembly for calibration that you used for the zero procedure. Collect a 1-liter sample containing ammonia and use the test kit to determine the ammonia level in a portion of this sample. Place the end of the inlet tube into this sample and let it run for 10 minutes. Then proceed as follows.

1. Scroll to the CAL menu section using the MENU key and press ENTER or the UP arrow key. **Cal NH3** will then be displayed.
2. Press the ENTER key. The screen will display a flashing **1-Ref** for span calibration or a **2-Zer** for zero calibration. Using the UP arrow key, set for a **1-Ref** span calibration and press ENTER.
3. The system now begins acquiring data for the calibration value. As data is gathered, the units for ppm and temperature may flash. Flashing units indicate that this parameter is unstable. The calibration data point acquisition will stop only when the data remains stable for a pre-determined amount of time. This can be overridden by pressing ENTER. If the data remains unstable for 10 minutes, the calibration will fail and the message **CalUnstable** will be displayed.
4. The screen will display the last measured ppm value and a message will be displayed prompting the user for the lab value. The user must then modify the screen value with the arrow keys and press ENTER. The system then performs the proper checks.
5. If accepted, the screen will display the message **PASS** with the new sensor slope reading, then it will return to the main measurement display. If the calibration fails, a message indicating the cause of the failure will be displayed and the FAIL icon will be turned on. The range of acceptable values for sensor slope is 20% to 500%. It may be necessary to rebuild the sensor as described in section 5.4, Sensor Assembly. Should the slope value remain out of range and result in calibration failures, review the Service Section of this manual, then contact the service dept. at ATI for further assistance.

The sensor offset value in % from the last span calibration is displayed on the lower line of the Default Menus for information purposes.

6.2 Temperature Calibration

The temperature calibration sequence is essentially a 1-point offset calibration that allows adjustments of approximately ± 5 °C.

The sensor temperature may be calibrated on line, or the sensor can be removed from the process and placed into a known solution temperature reference. In any case, it is critical that the sensor be allowed to reach temperature equilibrium with the solution in order to provide the highest accuracy. When moving the sensor between widely different temperature conditions, it may be necessary to allow the sensor to stabilize as much as one hour before the calibration sequence is initiated. If the sensor is on-line, the user may want to set the output HOLD feature prior to calibration to lock out any output fluctuations.

1. Scroll to the CAL menu section using the MENU key and press ENTER or the UP arrow key.
2. Press the UP arrow key until **Cal Temp** is displayed.
3. Press the ENTER key. The message **Place sensor in solution then press ENTER** will be displayed. Move the sensor into the calibration reference (if it hasn't been moved already) and wait for temperature equilibrium to be achieved. Press ENTER to begin the calibration sequence.
4. The calibration data gathering process will begin. The message **Wait** will flash as data is accumulated and analyzed. The °C or °F symbol may flash periodically if the reading is too unstable.
5. The message **Adjust value - press ENTER** will be displayed, and the right-most digit will begin to flash, indicating that the value can be modified. Using the UP and LEFT arrow keys, modify the value to the known ref solution temperature. Adjustments up to ± 5 °C from the factory calibrated temperature are allowed. Press ENTER.

Once completed, the display will indicate **PASS** or **FAIL**. If the unit fails, the temperature adjustment may be out of range, the sensor may not have achieved complete temperature equilibrium, or there may be a problem with the temperature element. In the event of calibration failure, it is recommended to attempt the calibration again immediately.

Part 7 – PID Controller Details

7.1 PID Description

PID controls, like many other control schemes, are used in chemical control to improve the efficiency of chemical addition or control. By properly tuning the control loop that controls chemical addition, only the amount of chemical that is truly required is added to the system, saving money. The savings can be substantial when compared to a system which may be simply adding chemical at a constant rate to maintain some minimal addition under even the worst case conditions. The PID output controller is highly advantageous over simple control schemes that just utilize direct (proportional only) 4-20 mA output connections for control, since the PID controller can automatically adjust the “rate” of recovery based on the error between the setpoint and the measured value – which can be a substantial efficiency improvement..

The PID controller is basically designed to provide a “servo” action on the 4-20 mA output to control a process. If the user requires that a measured process stay as close as possible to a specific setpoint value, the controller output will change from 0% to 100% in an effort to keep the process at the setpoint. To affect this control, the controller must be used with properly selected control elements (valves, proper chemicals, etc.) that enable the controller to add or subtract chemical rapidly enough. This is not only specific to pumps and valves, but also to line sizes, delays in the system, etc.

This section is included to give a brief description of tuning details for the PID controller, and is not intended to be an exhaustive analysis of the complexities of PID loop tuning. Numerous sources are available for specialized methods of tuning that are appropriate for a specific application.

7.2 PID Algorithm

As most users of PID controllers realize, the terminology for the actual algorithm terms and even the algorithms themselves can vary between different manufacturers. This is important to recognize as early as possible, since just plugging in similar values from one controller into another can result in dramatically different results. There are various basic forms of PID algorithms that are commonly seen, and the implementation here is the most common version; The ISA algorithm (commonly referred to as the “ideal” algorithm.)

$$\text{output} = P \left[e(t) + \frac{1}{I} \int e(t) dt + D \frac{de(t)}{dt} \right]$$

Where:

output =	controller output
P =	proportional gain
I =	integral gain
D =	derivative gain
t =	time
e(t) =	controller error (e=measured variable – setpoint)

Figure 22 - ISA (Ideal) Equation

The most notable feature of the algorithm is the fact the proportional gain term affects all components directly (unlike some other algorithms - like the “series” form.) If a pre-existing controller utilizes the same form of the algorithm shown above, it is likely similar settings can be made if the units on the settings are exactly the same. Be careful of this, as many times the units are the reciprocals of each other (i.e. reps-per-min, sec-per-rep.)

PID stands for “proportional, integral, derivative.” These terms describe the three elements of the complete controller action, and each contributes a specific reaction in the control process. The PID controller is designed to be used in a “closed-loop” control scheme, where the output of the controller directly affects the input through some control device, such as a pump, valve, etc.

Although the three components of the PID are described in the setting area (section 5.26), here are more general descriptions of what each of the PID elements contribute to the overall action of the controller.

- P** Proportional gain. With no “I” or “D” contribution, the controller output is simply a factor of the proportional gain multiplied by the input error (difference between the measured input and the controller setpoint.) Because a typical chemical control loop cannot react instantaneously to a correction signal, proportional gain is typically not efficient by itself – it must be combined with some integral action to be useful. Set the P term to a number between 2-4 to start. Higher numbers will cause the controller action to be quicker.
- I** Integral gain. Integral gain is what allows the controller to eventually drive the input error to zero – providing accuracy to the control loop. It must be used to affect the accuracy in the servo action of the controller. Like proportional gain, increasing integral gain results in the control action happening quicker. Set the I term to a number between 3-5 to start (1-2 more than P). Like proportional gain, increasing the integral term will cause the controller action to be quicker.

- D Derivative gain. The addition of derivative control can be problematic in many applications, because it greatly contributes to oscillatory behavior. In inherently slow chemical control processes, differential control is generally added in very small amounts to suppress erratic actions in the process that are non-continuous, such as pumps and valves clicking on and off. However, as a starting point for chemical process control, it's best to leave the "D" term set to 0.

Based on these descriptions, the focus on tuning for chemical applications really only involves adjustment of "P" and "I" in most cases. However, increasing both increases the response of the controller. The difference is in the time of recovery. Although combinations of high "P's" and low "I" will appear to operate the same as combinations of low "P's" and high "I's", there will be a difference in rate of recovery and stability. Because of the way the algorithm is structured, large "P's" can have a larger impact to instability, because the proportional gain term impacts all the other terms directly. Therefore, keep proportional gain lower to start and increase integral gain to achieve the effect required.

Many of the classical tuning techniques have the user start with all values at 0, and then increase the P term until oscillations occur. The P value is then reduced to $\frac{1}{2}$ of the oscillatory value, and the I term is increased to give the desired response. This can be done with the Q46N analyzer, with the exception that the I term should start no lower than 1.0.

If it appears that even large amounts of integral gain (>20) don't appreciably increase the desired response, drop I back to about 1.0, and increase P by 1.00, and start increasing I again. In most chemical control schemes, I will be approximately 3 times the value of P.

7.3 Classical PID Tuning

Unlike many high speed position applications where PID loops are commonly used, the chemical feed application employed by this instrument does not require intense mathematical exercise to determine tuning parameters for the PID. In fact, the risk of instability is far greater with overly tuned PID control schemes. In addition, many of the classical mathematical exercises can be damaging or wasteful in the use of chemicals when the process is bumped with large amounts of input error to seek a response curve. Because of this, the general adjustment guidelines described in section 7 are sufficient for almost all application tuning for this instrument. Beyond this, many sources are available for classical tuning methods.

7.4 Common PID Pitfalls

The most common problem occurring in PID control applications involves the false belief that proper settings on only the PID controller can balance any process to an efficient level.

Close-loop control can only be effective if all elements in the loop are properly selected for the application, and the process behavior is properly understood. Luckily, the nature of simple chemical control processes are generally slow in nature. Therefore, even a de-tuned controller (one that responds somewhat slowly) can still provide substantial improvements to setpoint control. In fact, damaging oscillatory behavior is far more likely in tightly tuned controllers where the user attempted to increase response too much.

When deciding on a PID control scheme, it is important to initially review all elements of the process. Sticking valves, undersized pumps, or delays in reaction times associated with chemical addition can have a dramatic effect on the stability of the control loop. When controlling a chemical mix or reaction, the sensor should be placed in a location that ensures proper mixing or reaction time has occurred.

The easiest processes to control with closed-loop schemes are generally linear, and symmetrical, in nature. For example, controlling level in tank where the opening of valve for a fixed period of time corresponds linearly to the amount that flows into a tank. Chemical control processes can be more problematic when the nature of the setpoint value is non-linear relative to the input of chemical added. For example, pH control of a process may appear linear only in a certain range of operation, and become highly exponential at the extreme ranges of the measuring scale. In addition, if a chemical process is not symmetrical, that means it responds differentially to the addition and subtraction of chemical. It is important in these applications to study steady-state impact as well as step-change impact to process changes. In other words, once the process has apparently been tuned under normal operating conditions, the user should attempt to force a dramatic change to the input to study how the output reacts. If this is difficult to do with the actual process input (the recommended method), the user can place the control in manual at an extreme control point such as 5% or 95%, and release it in manual. The recovery should not be overly oscillatory. If so, the loop needs to be de-tuned to deal with that condition (reduce P and/or I.)

Part 8 – System Maintenance

8.1 General

The Q46N Dissolved Ammonia System will generally provide unattended operation over long periods of time. With proper care, the system should continue to provide measurements indefinitely. For reliable operation, maintenance on the system must be done on a regular schedule. Keep in mind that preventive maintenance on a regular schedule is much less troublesome than emergency maintenance that always seems to come at the wrong time.

8.2 Analyzer Maintenance

No unusual maintenance of the analyzer is required if installed according to the guidelines of this operating manual. If the enclosure door is frequently opened and closed, it would be wise to periodically inspect the enclosure sealing gasket for breaks or tears.

8.3 Sensor Maintenance

Sensor maintenance is required for accurate measurements. The primary requirement is simply to keep the sensor membrane clean. The membrane is a micro-porous polymer that is resistant to anything that will be encountered in water streams. However, deposits can form on the surface or in the pores of the membrane, and these deposits will reduce the sensitivity. Certain constituents in water mainly iron and manganese will form precipitates when the water is chlorinated. These precipitates can sometimes form a coating on the membrane.

Because membranes are micro-porous, they can be relatively difficult to clean effectively. Immersing the tip of the sensor in 1N nitric acid solution will sometimes remove deposits that cause low sensitivity, but this is not always the case. The recommended practice is to simply replace the membrane when it becomes fouled. To change a membrane, follow the Sensor Assembly procedure on page 24 of this manual. Do not reuse the electrolyte from the sensor when changing a membrane. Always refill with fresh electrolyte. The electrolyte is stable and does not have a limited shelf life.

Refer again to the explanation of the sensor slope number after an accepted span calibration on the lower MEASURE screen. In normal operation, the slope of the sensor output will decrease over time as the membrane becomes fouled. This reduction indicates that the sensor is losing sensitivity to ammonia. It is good practice to replace the membrane if the slope number falls to 30-40%. The value will not go below 20%.

Even if no buildup is apparent on the membrane, it should be changed on a regular schedule. The recommended membrane change interval is every 3 months. For high purity water applications, this can probably be extended if desired, but a more frequent changing interval is a small price to pay for avoiding membrane failure at the wrong time.

While the sensor is disassembled for membrane changing, examine the condition of the o-rings on both ends of the electrolyte chamber. If the o-rings show any signs of damage, replace them with new ones from the spare parts kit. It is good practice to change these o-rings once a year, regardless of their condition.

8.31 Sensor Acid Cleaning

Over an extended operating period, sensors can slowly accumulate deposits on the surface of the measuring electrode. Typically, this type of buildup occurs over years of operation, but can sometimes occur more quickly in high levels of manganese, iron, or other metals are dissolved in the water. The measuring electrode can be “acid cleaned” using nitric acid solutions.

WARNING

THIS ACID CLEANING PROCEDURE INVOLVES THE USE OF HIGHLY CORROSIVE ACID SOLUTIONS. IT SHOULD ONLY BE COMPLETED BY TRAINED PERSONNEL USING PROTECTIVE EYEWEAR AND GLOVES. IF THERE IS ANY DOUBT ABOUT YOUR ABILITY TO SAFELY ACCOMPLISH THIS PROCEDURE, RETURN THE SENSOR TO ATI FOR FACTORY CLEANING!

To acid clean the electrode assembly, remove the electrolyte chamber from the sensor so that the so that the electrodes are exposed. Then follow the procedure below.

1. Place a small amount of 50% nitric acid solution in a beaker. Put in just enough so that the tip of the sensor can be submerged without any contact with the small electrode coil just above the tip.
2. Allow the sensor to soak in this acid solution for 2 minutes. Remove the sensor body and rinse the tip thoroughly with distilled water. Discard the nitric acid safely and according to all environmental regulations.

3. Fill the beaker with distilled water to the level sufficient to submerge both the entire electrode assembly. Do not allow the connector at the back of the sensor to be submerged. Allow the electrodes to soak in distilled water for 30 minutes.
4. Put a new membrane and fresh electrolyte in the electrolyte chamber and reassemble the sensor. Connect to the ammonia monitor electronics and allow the sensor to stabilize for at least 24 hours. The sensor can be placed in the flow cell with sample water running through it during stabilization. However, the readings will not be useful for 12-24 hours after an acid cleaning.

8.4 Inlet Filter Maintenance

An inlet filter is provided for the purpose of filtering the process sample down to 40-60 micron, which increases the life of the sensor membrane as compared to not filtering. The inlet filter flow block is located on the exterior of the main enclosure, latch side and is gray in color.

To access the filter, remove the ¼" tube from the barb fitting on the yellow 3-way valve. See Figure 23. The filter holder assembly can now be unscrewed from the top of the inlet flow block. The filter is located on the bottom of this assembly and can be unscrewed for either cleaning or replacement. Light cleaning can be accomplished by soaking the filter in warm soapy water for a few hours. Severely coated or well used filters should be replaced.

8.5 Flow Cell Maintenance

The maintenance on the flow cell is simple cleaning. The flow cell is clear to make examination of the condition of the sensor easier without interfering with operations. The flow cell may be cleaned by wiping or by washing with detergents or dilute acid. Do not try to clean with solvents as the acrylic may craze or crack.

Change the o-ring in the flow cell yearly or if any damage is observed. If insertion of the sensor into the flow cell becomes difficult, use silicon grease to lubricate the o-rings that hold the sensor in place. Use only enough grease to provide surface lubrication. Excess grease could foul the sensor membrane.

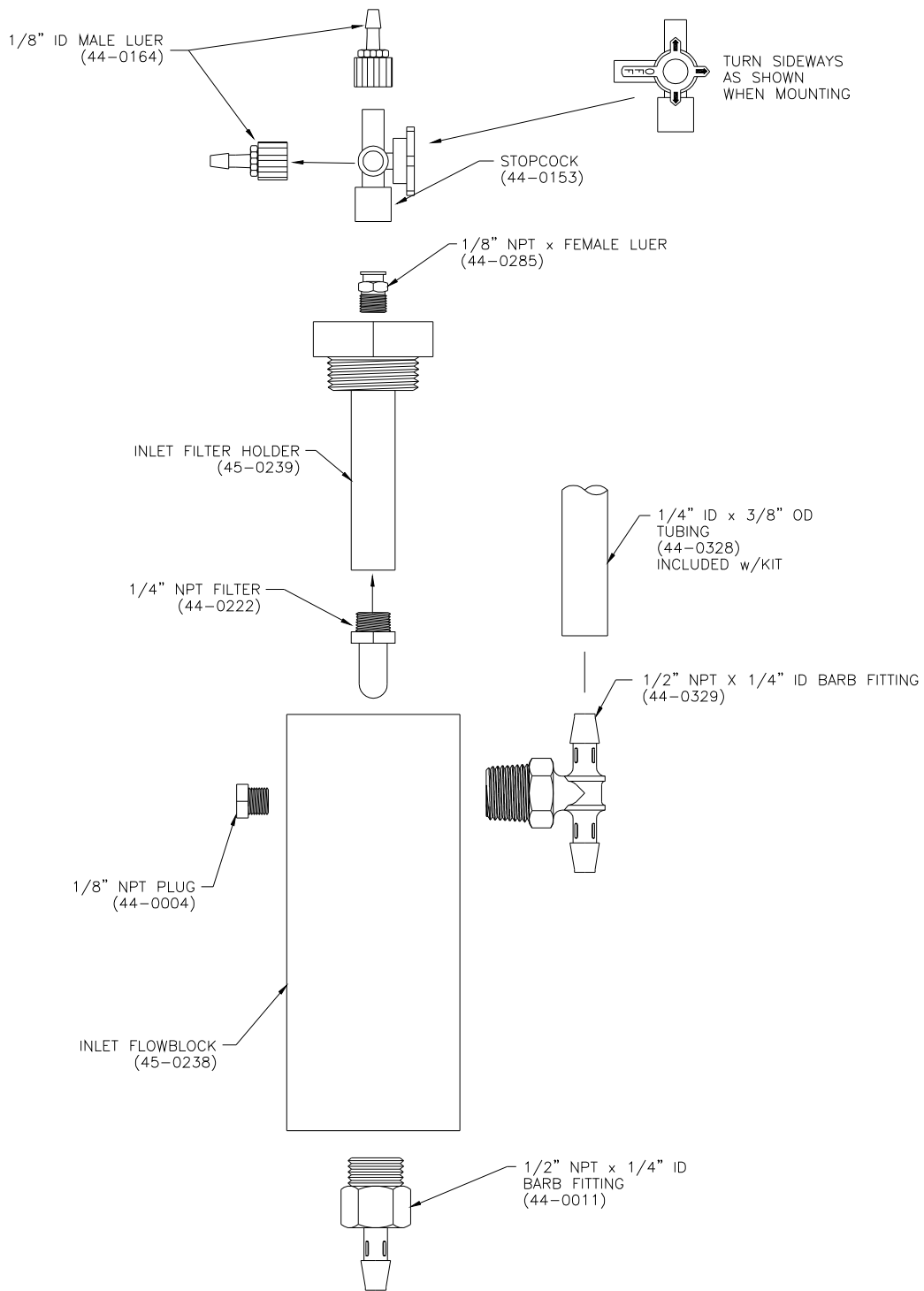

Figure 23 - Inlet Flowblock Exploded View

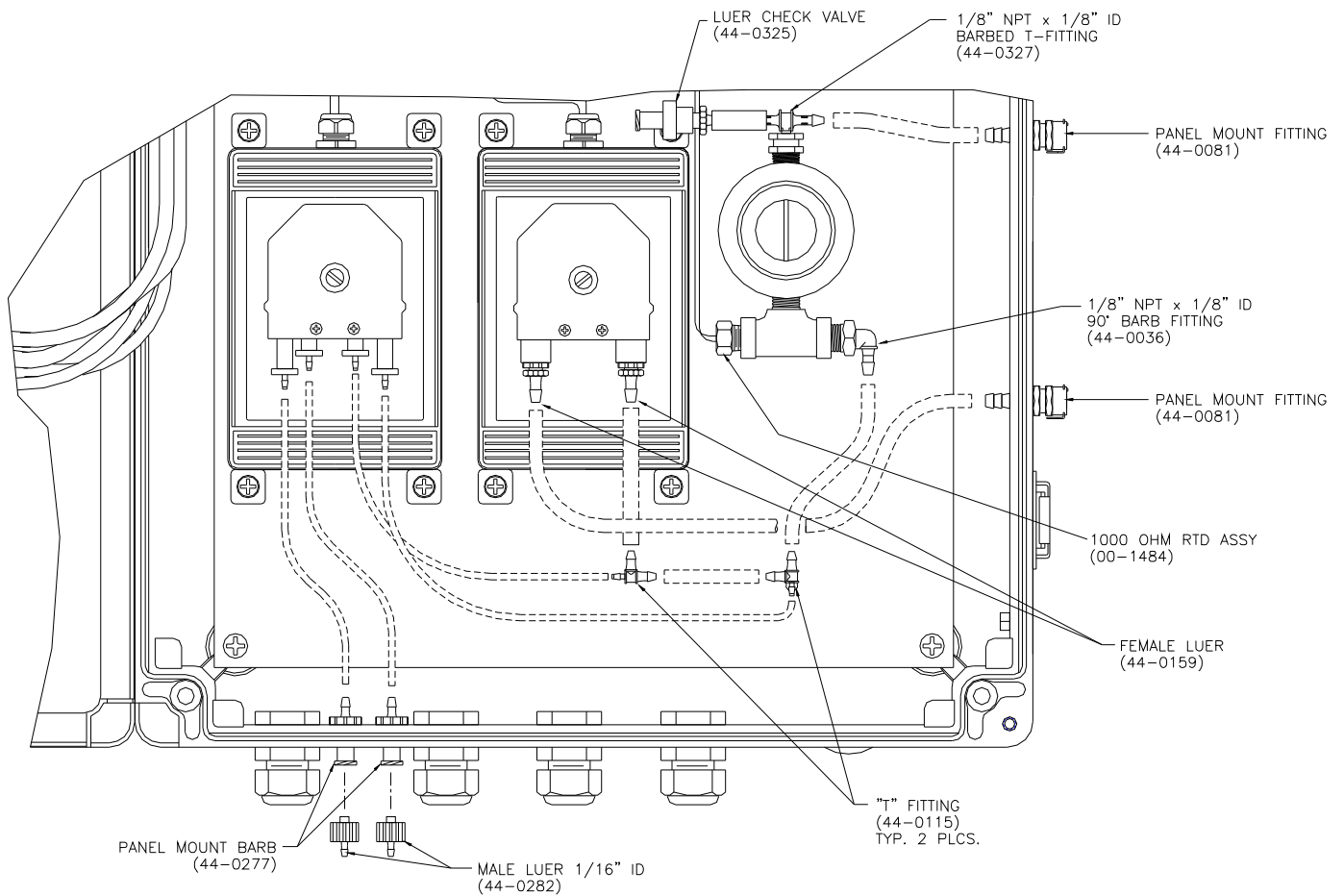

Figure 24 - System Fittings Exploded View

Part 9 – Troubleshooting

9.1 General

The information included in this section is intended to be used in an attempt to quickly resolve an operational problem with the system. During any troubleshooting process, it will save the most time if the operator can first determine if the problem is related to the analyzer, sensor, or some external source. Therefore, this section is organized from the approach of excluding any likely external sources, isolating the analyzer, and finally isolating the sensor. If these procedures still do not resolve the operational problems, any results the operator may have noted here will be very helpful when discussing the problem with the factory technical support group.

9.2 External Sources of Problems

To begin this process, review the connections of the system to all external connections.

1. Verify the analyzer is earth grounded. For all configurations of the analyzer, an earth ground connection **MUST** be present for the shielding systems in the electronics to be active. Grounded conduit provides no earth connection to the plastic enclosure, so an earth ground wiring connection must be made at the power input terminal strip. Verify metal shield is present over incoming power connections. This shield is for safety purposes, but also blocks electrical spikes from relay and power wiring.
2. Verify the proper power input is present (115 or 230 VAC).
3. Verify the loads on any 4-20 mA outputs do not exceed the limits in the Instrument Specifications. During troubleshooting, it is many times helpful to disconnect all these outputs and place wire-shorts across the terminals in the instrument to isolate the system and evaluate any problems which may be coming down the analog output connections.
4. Do not run sensor cables or analog output wiring in the same conduits as power wiring. If low voltage signal cables must come near power wiring, cross them at 90° to minimize coupling.
5. If rigid conduit has been run directly to the Q46 enclosure, check for signs that moisture has followed conduit into the enclosure.

6. Check for ground loops. Although the membrane sensor is electrically isolated from the process water, high frequency sources of electrical noise may still cause erratic behavior in extreme conditions. If readings are very erratic after wiring has been checked, check for a possible AC ground loop by temporarily disconnecting feed and drain lines from the filter assembly. The reading should stabilize.
7. On relay based systems, check the load that is connected to the relay contacts. Verify the load is within the contact rating of the relays. Relay contacts which have been used for higher power AC current loads may become unsuitable for very low signal DC loads later on because a small amount of pitting can form on the contacts. If the load is highly inductive (solenoids, motor starters, large aux relays), note that the contact rating will be de-rated to a lower level. Also, due to the large amount of energy present in circuits driving these types of loads when they are switched on an off, the relay wiring placement can result in electrical interference for other devices. This can be quickly resolved by moving wiring, or by adding very inexpensive snubbers (such As Quencharcs) to the load.
8. Carefully examine any junction box connections for loose wiring or bad wire stripping. If possible, connect the sensor directly to the analyzer for testing.
9. Check sensor membrane for fouling. Look closely for signs of grease or oil which may be present. Replace membrane and electrolyte, allow to stabilize, and re-check. The procedure in Sensor Assembly, on page 24, must be followed when replacing the membrane.

9.3 Analyzer Tests

1. Disconnect power and completely disconnect all output wiring coming from the analyzer. Remove sensor wiring, relay wiring, and analog output wiring. Re-apply power to the analyzer.
2. Using the Simulate feature, check operation of analog outputs and relays with a DMM.
3. Check cell drive circuit. With a digital voltmeter (DVM), measure the voltage between the ORANGE and BLUE terminals with the BLUE jumpered to the WHITE the monitor to verify that the millivolt value is actually -400 mV.
4. Check TC drive circuit. Place a wire-short between the GREEN and BLACK terminals. With a digital voltmeter (DVM), measure the voltage between the BLACK and RED terminals on the back of the monitor to verify that the TC drive circuit is producing about 4.8-5.1 VDC open circuit. Remove DVM

completely and connect a 1000 Ohm resistor from the BLACK to RED terminals. The temperature reading should display approximately 0°C and the ammonia reading should display approximately 0 ppm.

9.4 Chemistry System Tests

Problems with the ammonia monitor are most likely to originate with the sample inlet filter, the sample and reagent pumps, or the sensor. If problems arise, the first thing to do is verify certain basic chemistry system functions.

1. Check the inlet filter assembly for any kind of blockage in the inlet filter. If necessary, remove the filter and immerse it in hot water for 10 minutes to clean.
2. Check to see that the sample pump outlet flow rate is approximately correct. The pump should deliver sample at about 13 cc/min., or about 4 oz. in 10 minutes. If flow is low, replace the peristaltic pump tubing. This tubing should be changed every 6 months.
3. Check that the two reagent pumps are delivering reagent to the chemical injection fittings. These chemicals can cause skin irritation. **USE PROTECTIVE GLOVES WHEN TESTING REAGENT PUMP FOR PROPER OUTPUT.** To do this, disconnect the sample inlet so that the sample pump is only pulling in air. Stop the pumps temporarily by opening the fuse lever at the AC terminal blocks. Disconnect the reagent outlet tubes from the two injection tees and then turn pump power back on. The pump delivers reagent at a rate of 0.05 cc/min. You should see a small drop of reagent slowly form at the outlet of each tube. If no reagent is being delivered, replace the reagent pump tubes on the peristaltic pump. These tubes should be replaced every 6 months.
4. Check the sensor for membrane fouling. Turn the pumps off and unplug the sensor cable. Remove the sensor from the flowcell (hold a small sponge or paper towel under the flowcell when removing the sensor to catch the small amount of sample that will spill out).

If all of these chemistry systems components are functioning properly, the ammonia monitor should produce valid readings and any problems are likely to be associated with the electronic monitor or the interconnecting cable.

9.5 Display Messages

The Q46 Series instruments provide a number of diagnostic messages which indicate problems during normal operation and calibration. These messages appear as prompts on the secondary line of the display or as items on the Fault List.

MESSAGE	DESCRIPTION	POSSIBLE CORRECTION
Max is 200	Entry failed, maximum user value allowed is 200.	Reduce value to ≤ 200
Min is 200	Entry failed, minimum value allowed is 200.	Increase value to ≥ 200
Cal Unstable	Calibration problem, data too unstable to calibrate. Icons will not stop flashing if data is too unstable. User can bypass by pressing ENTER.	Clean sensor, get fresh cal solutions, allow temperature and conductivity readings to fully stabilize, do not handle sensor or cable during calibration.
Out of Range	Input value is outside selected range of the specific list item being configured.	Check manual for limits of the function to be configured.
Locked!	Transmitter security setting is locked.	Enter security code to allow modifications to settings.
Unlocked!	Transmitter security has just been unlocked.	Displayed just after security code has been entered.
Offset High	The sensor zero offset point is out of the acceptable range of -25 to +25 nA.	Check wiring connections to sensor. Allow sensor to operate powered a minimum of 12 hours prior to first zero cal.
Sensor High	The raw signal from the sensor is too high and out of instrument range.	Check wiring connections to sensor.
Sensor Low	The raw signal from the sensor is too low.	Check wiring connections to sensor.
NH3 High	The ammonia reading is greater than the maximum of the User-selected range.	The ammonia reading is over operating limits. Set measuring range to the next highest level.
Temp High	The temperature reading is $> 55^{\circ}\text{C}$.	The temperature reading is over operating limits. Check wiring and expected temp level. Perform RTD test as described in sensor manual. Recalibrate sensor temperature element if necessary.
Temp Low	The temperature reading is $< -10^{\circ}\text{C}$	Same as "Temp High" above.
TC Error	TC may be open or shorted.	Check sensor wiring and perform RTD test as described in sensor manual. Check j-box connections.

Figure 25 - Q46N Display Messages

MESSAGE	DESCRIPTION	POSSIBLE CORRECTION
NH3 Cal Fail	Failure of ammonia calibration. FAIL icon will not extinguish until successful calibration has been performed, or 30 minutes passes with no keys being pressed.	Clean sensor redo zero and span calibration. If still failure, sensor slope may be less than 25% or greater than 500%. Perform sensor tests as described in section 10.6. Replace sensor if still failure.
TC Cal Fail	Failure of temperature calibration. FAIL icon will not extinguish until successful calibration has been performed, or 30 minutes passes with no keys being pressed.	Clean sensor, check cal solution temperature and repeat sensor temp calibration. TC calibration function only allows adjustments of +/- 6 °C. If still failure, perform sensor tests as described in section 10.6. Replace sensor if still failure. .
EPROM Fail	Internal nonvolatile memory failure	System failure, consult factory.
Chcksum Fail	Internal software storage error.	System failure, consult factory.
Display Fail	Internal display driver fail.	System failure, consult factory.
Range Cal Fail	Failure of factory temperature calibration.	Consult factory.

Figure 26 - Q46N Display Messages (Cont'd)

9.6 Sensor Tests

1. Check the membrane condition. A membrane that is not stretched smoothly across the tip of the sensor will cause unstable measurements. If necessary, change membrane and electrolyte.
2. Ammonia sensors can be tested with a digital voltmeter (DVM) to determine if a major sensor problem exists. Follow the steps below to verify sensor integrity:
 - A. Disconnect the six sensor wires from the monitor. Those wires are color coded white, orange, blue, red, black, and green.
 - B. Remove the electrolyte chamber from the sensor and dry the electrodes with a paper towel.
 - C. Connect a DVM between the white and orange wires and between the blue and white wires. Reading resistance, you should find an open circuit value of infinite resistance. There must be no measurable resistance at all between these two sets of wires. Any resistance at all indicates either water in the cable connector or the breakdown in an electrode seal.
 - D. Connect a DVM between the red and white wires. The red wire is part of the RTD circuit and the white wire is part of the measuring cell. There should be no connection. Reading resistance, you should find an open circuit value of infinite resistance. Any resistance at all indicates either water in the cable connector or the breakdown in an electrode seal.
 - E. Connect the DVM between the red and black wires. These are the RTD leads, and you should find a resistance value that depends on the temperature. The table below lists the resistance values for various temperatures. Reading resistance between the red and green wires should give exactly the same values as between red and black.

Temperature °C	Resistance Ω
0	1000
5	1019
10	1039
15	1058
20	1078
25	1097
30	1117
35	1136
40	1155
45	1175
50	1194

Figure 27 - Pt100 RTD Table

If you suspect that water has gotten into a cable connection on a flow type sensor or into the plug connection of a submersible sensor, disconnect the cable and allow the parts of the sensor to sit in a warm place for 24 hours. If water in the connector is the problem, it should dry out sufficiently to allow normal sensor operation. However, steps 4 and 5 above will have to be repeated after drying to see if the problem is gone.

Acid clean the sensor electrodes in accordance with the procedure in section 8.31.

Spare Parts

<u>Part No.</u>	<u>Description</u>
07-0316	Q46 Ammonia monitor electronics, 100-240 VAC
07-0318	Q46 Ammonia monitor electronics with Profibus, 100-240 VAC
03-0392	Q46 Ammonia front lid assembly
01-0306	Power supply circuit board assembly (specify options if required)
00-1484	Pt 1000 RTD Assembly
00-1478	Dissolved Ammonia sensor
45-0007	Electrolyte chamber
48-0001	Membrane holder, type 316 stainless steel
05-0075*	Membranes, pkg. of 10
05-0004*	Spare Parts Kit, screw & o-ring
09-0056*	Ammonia electrolyte, 4 oz (120 cc)
09-0057	Ammonia Reagent A Buffer
09-0058	Ammonia Reagent A Stabilizer
23-0003	Fuse, 6.3 A (in lever fuse holder)
23-0022	Fuse, 250mA, 250V, TR-5 (for AC and DC Analyzers)
38-0063	Terminal block plug, 2 position (outputs)
38-0064	Terminal block plug, 6 position (relays)
38-0065	Terminal block plug, 3 position (power)
31-0173	Ribbon cable assembly for AC units
42-0014	Sensor Flowcell O-ring
45-0068	Sensor Flowcell
03-0321	Sample Pump Assembly, 115 VAC
03-0322	Reagent Pump Assembly, 115 VAC
03-0323	Sample Pump Assembly, 230 VAC
03-0324	Reagent Pump Assembly, 230 VAC
05-0044	Sample pump tubing (pkg. of 5, precut)
05-0045	Reagent pump tubing (pkg. of 10)
54-0007	Tube Holder – 1 channel (Sample Pump)
54-0008	Tube Holder – 2 channel (Reagent Pump)
54-0009	Pressure Plate
44-0222	Polyethylene Inlet Filter

Spare Parts

Fittings found on page 63

44-0004	1/8" NPT plug
44-0011	1/2" NPT Barb Fitting
44-0153	Stopcock 3-way Valve
44-0159	Female Luer
44-0164	1/8" Male Luer
44-0185	Luer Adapter
44-0329	1/2" NPT x 1/4" I.D. Tee Fitting
44-0328	1/4" I.D. silicon tubing

Fittings found on page 64

44-0036	1/8" NPT 90° Barb Fitting
44-0081	Panel Mount Fitting
44-0115	"T" Fitting
44-0159	Female Luer
44-0277	Panel Mount Barb
44-0282	Male Luer
44-0325	Luer check valve

Lock/Unlock Code: 1462