

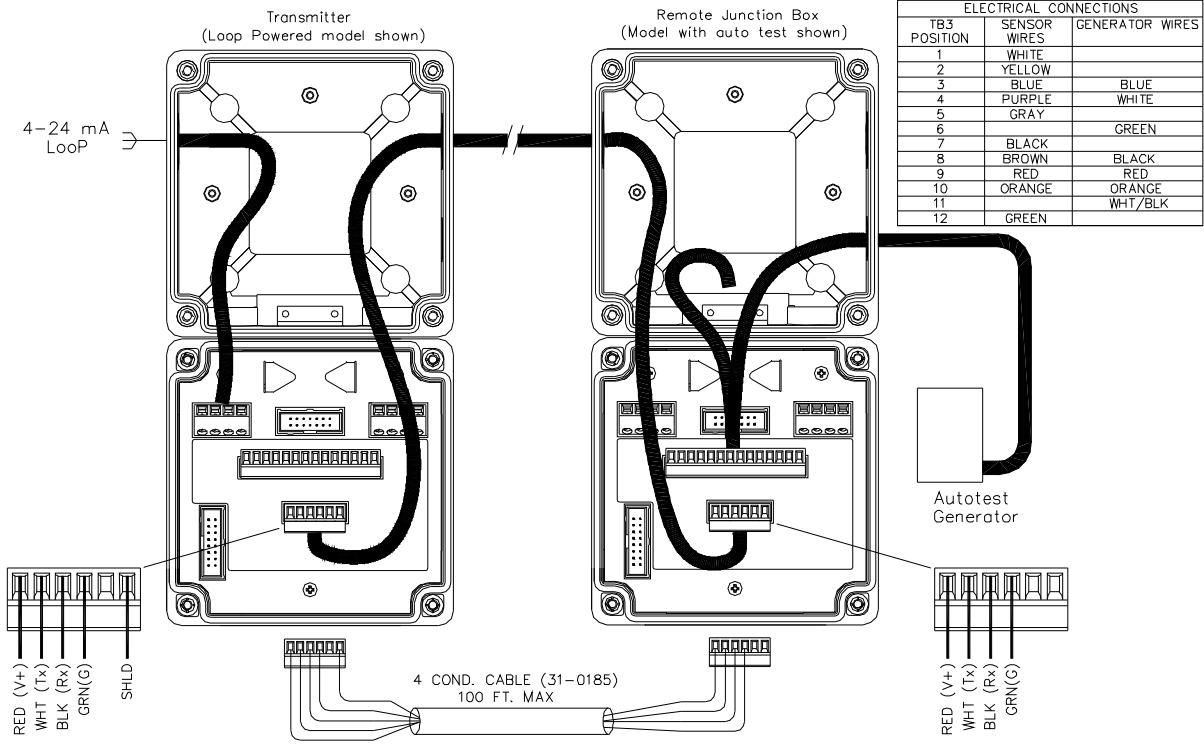





**REMOTE SYSTEM INTERCONNECT WIRING DIAGRAM**



ATI-0840

**HEATED SENSOR WIRING DIAGRAMS**

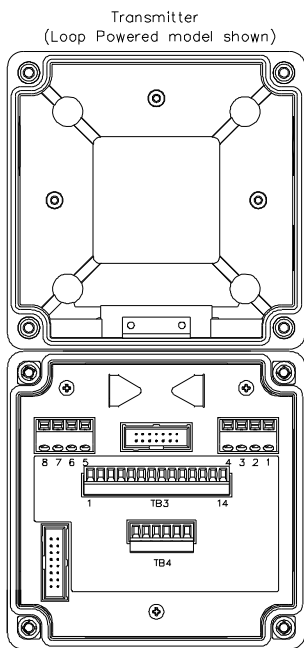

ELECTRICAL CONNECTIONS		
TB3 POSITION	SENSOR WIRES	GENERATOR WIRES
1	WHITE	
2	YELLOW	
3	BLUE	BLUE
4	PURPLE	WHITE
5	GRAY	
6		GREEN
7	BLACK	
8	BROWN	BLACK
9	RED	RED
10	ORANGE	ORANGE
11		WHT/BLK
12	GREEN	
13	* PINK	
14	* PINK	

\* IF USING THE 6 FT. HEATED SENSOR (00-1878) RED WIRES WILL BE CONNECTED IN PLACE OF PINK WIRES

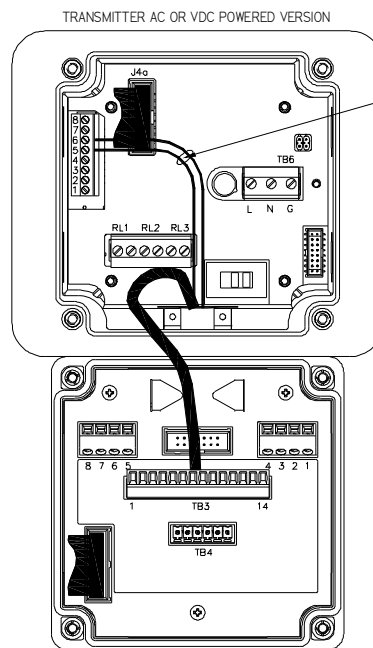

IF USING CLOSE COUPLED HEATED SENSOR (00-1699), WIRE COLORS WILL BE PINK

IF USING 6 FT. HEATED SENSOR (00-1878), WIRE COLORS WILL BE RED.

Conductor Colors		
T/B Pos	Sensor Wires	Generator Wires
1	WHITE	
2	YELLOW	
3	BLUE	BLUE
4	PURPLE	WHITE
5	GRAY	
6		GREEN
7	BLACK	
8	BROWN	BLACK
9	RED	RED
10	ORANGE	ORANGE
11		WHT / BLK
12	GREEN	

ATI-0903

**REMOTE SYSTEM (w/HEATED SENSOR) INTERCONNECT WIRING DIAGRAM (LOOP POWERED)**

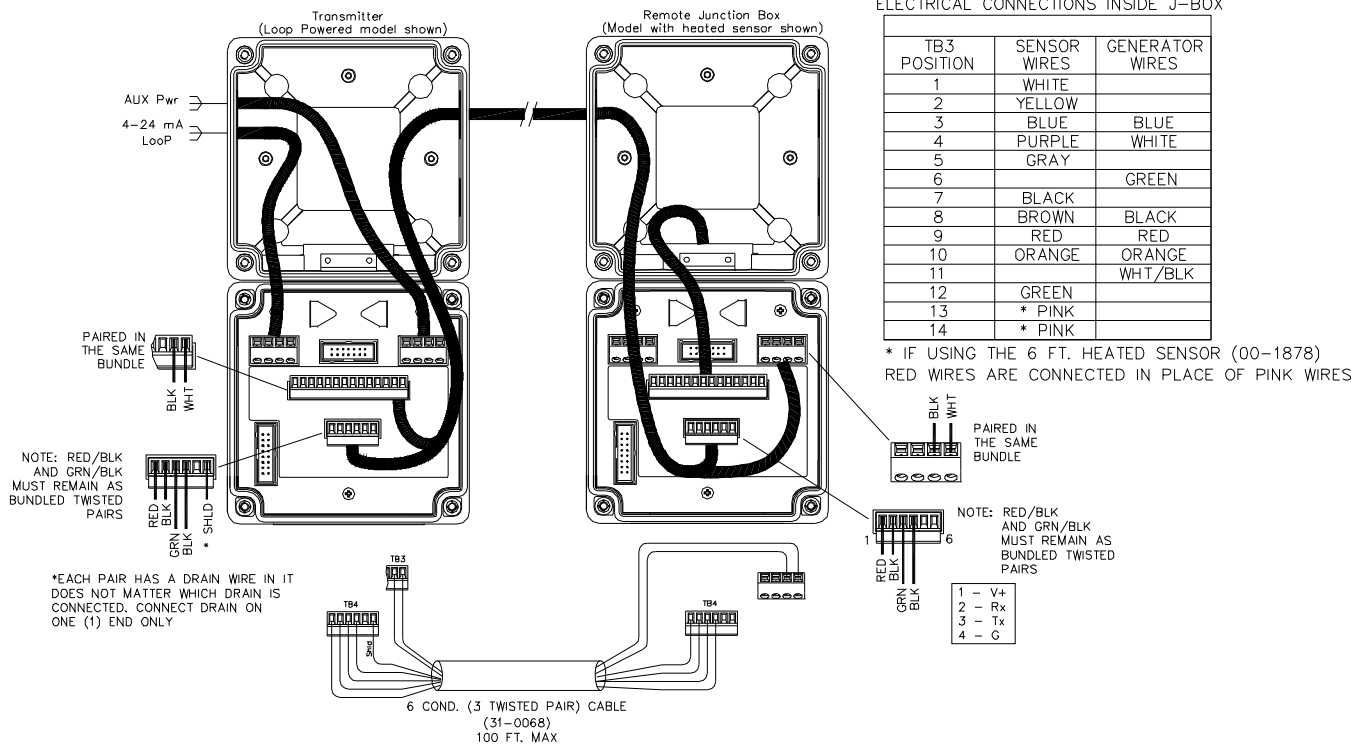

**REMOTE SYSTEM (w/HEATED SENSOR) INTERCONNECT WIRING DIAGRAM (AC OR VDC POWERED)**

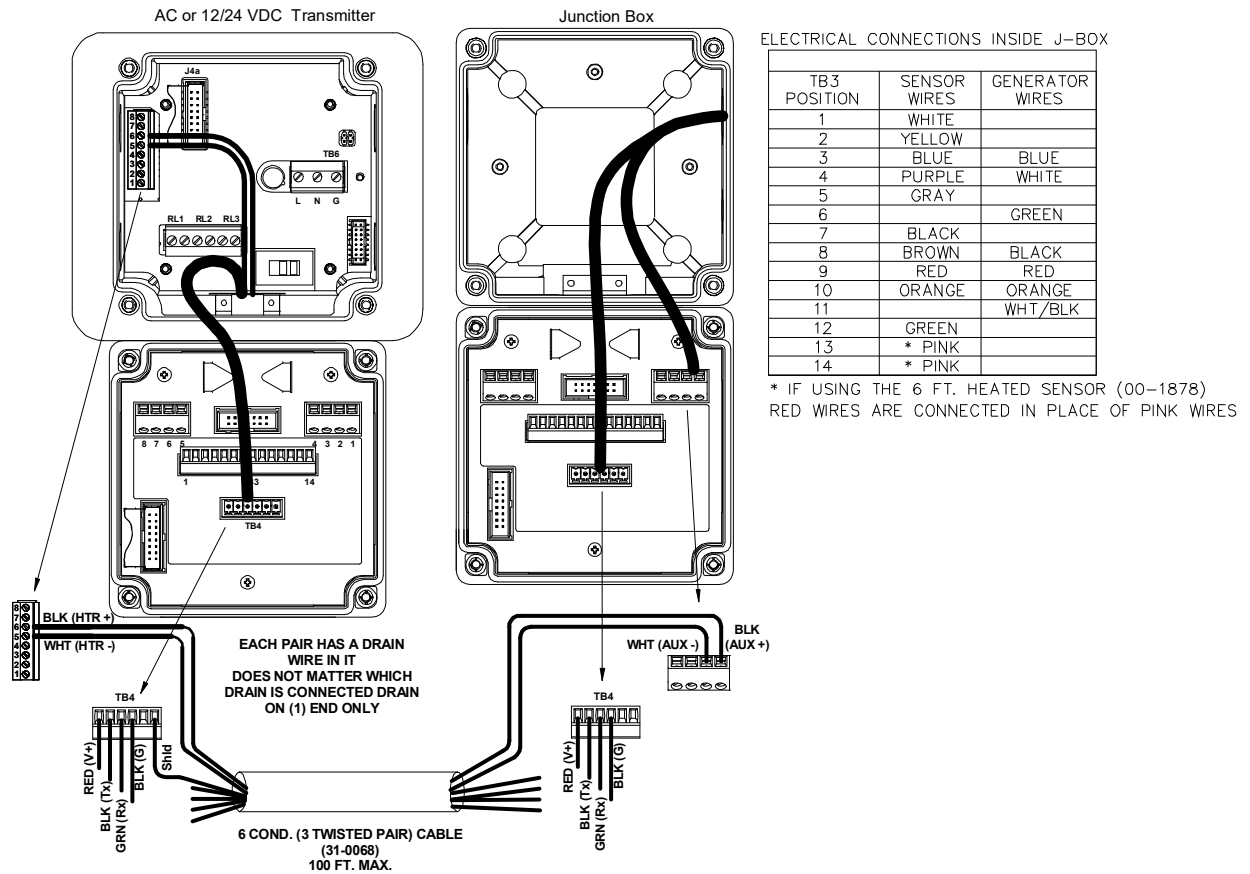

**RELAY BOARD CONNECTIONS**

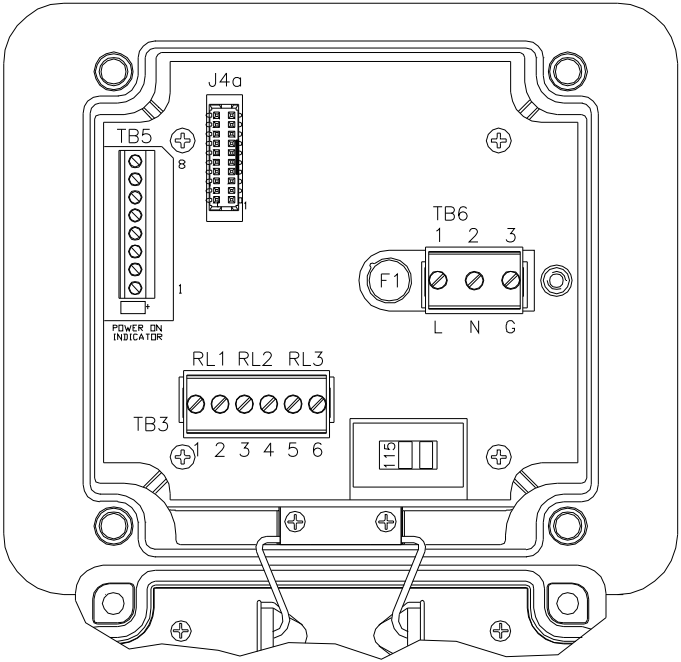

- J4a  
CONNECTS TO (AUX)  
ON FRONT LID OF TRANSMITTER
- TB3  
1 - RL1 Contact NO  
2 - RL1 Contact C  
3 - RL2 Contact NO  
4 - RL2 Contact C  
5 - RL3 Contact NC  
6 - RL3 Contact C
- TB5  
1 - RS232/485 Power (+)  
2 - Remote Reset (+)  
3 - Remote Reset (-)  
4 - RS232/485 Power (-)  
5 - Heater (Lo)  
6 - Heater (Hi)  
7 - Loop Power (+)  
8 - Loop Power (-)
- TB6 - (AC PWR)  
1 (L) - 115/230VAC, 60/50 Hz.  
2 (N) - Neutral  
3 (G) - Ground
- TB6 - (DC PWR)  
1 (+) - 12-30VDC  
2 (-) - COMMON  
3 (G) - Ground

ATI-0847

**TRANSMITTER ACCESSORIES**

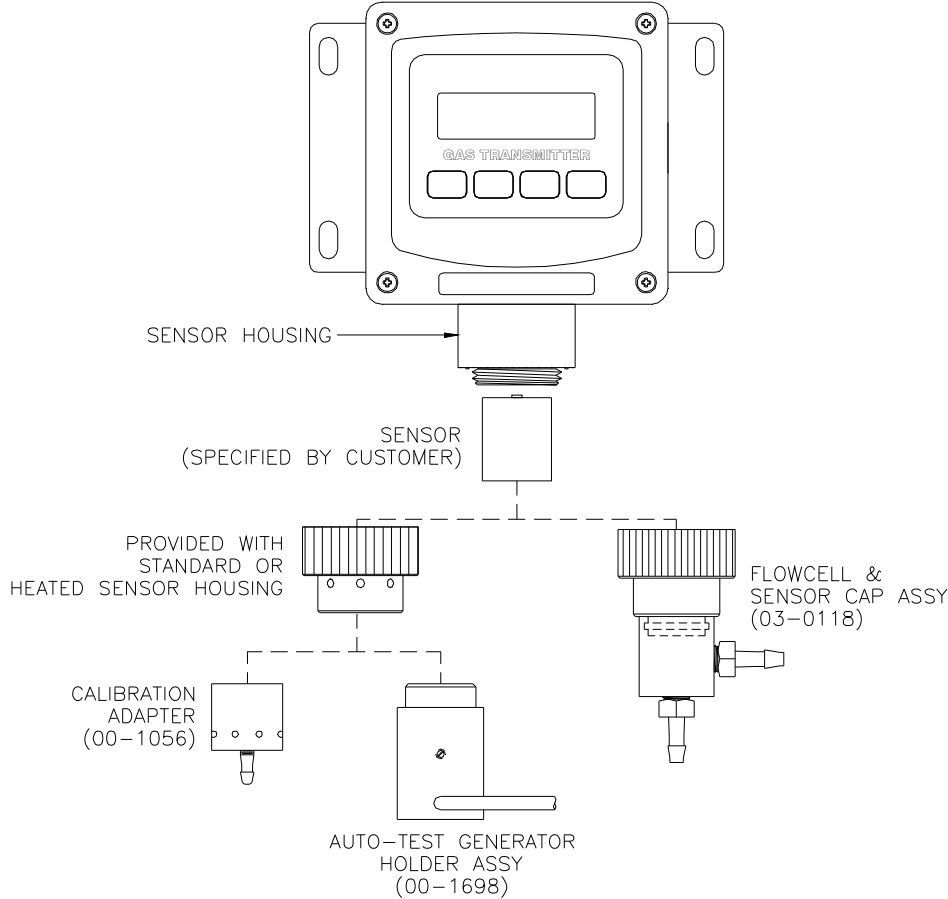

ATI-0820

**6ft. REMOTE SENSOR DIMENSIONS  
(00-1702)**

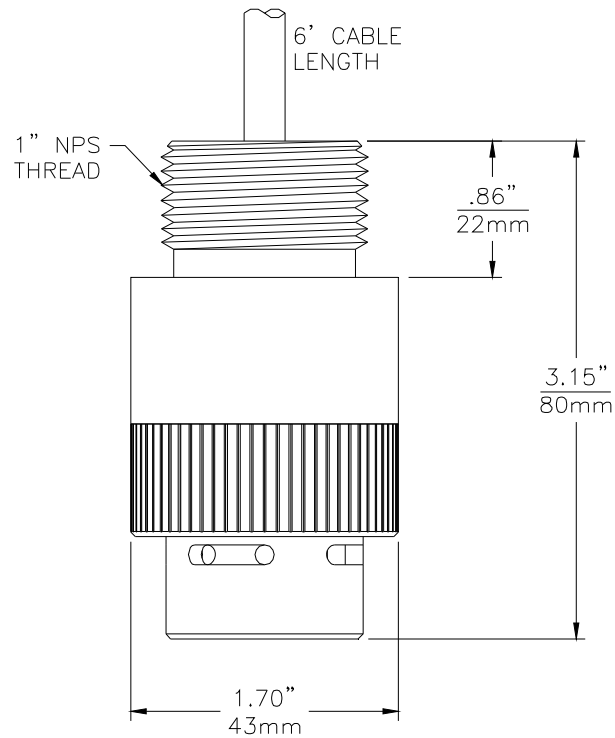

ATI-1032

**INSERTION SENSOR DIMENSIONS**

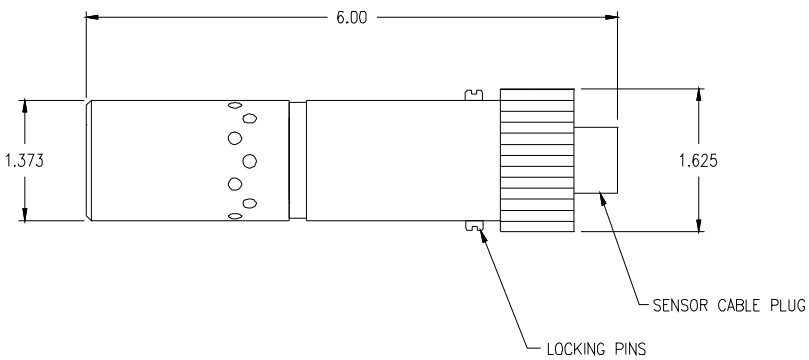

ATI-0669

**PIPE ADAPTER DIMENSIONS**

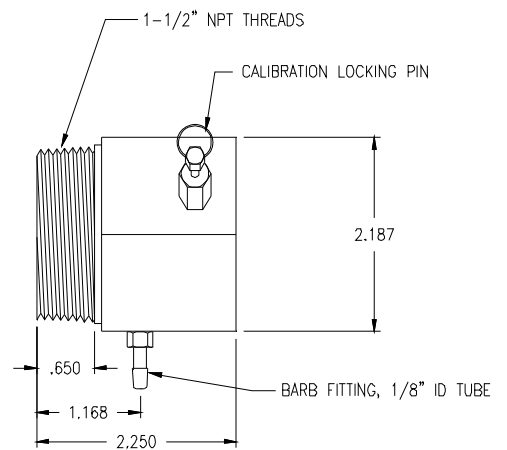

ATI-0670

**INSERTION PROBE - OPERATING MODE**

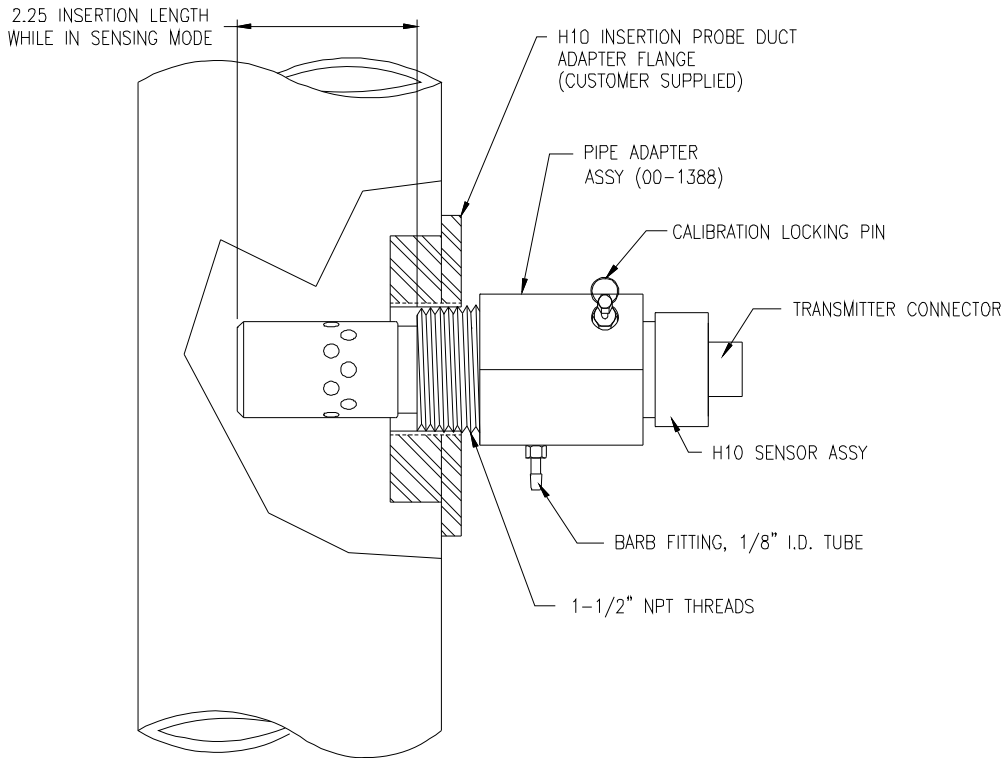

ATI-0663

**INSERTION PROBE - CALIBRATING MODE**

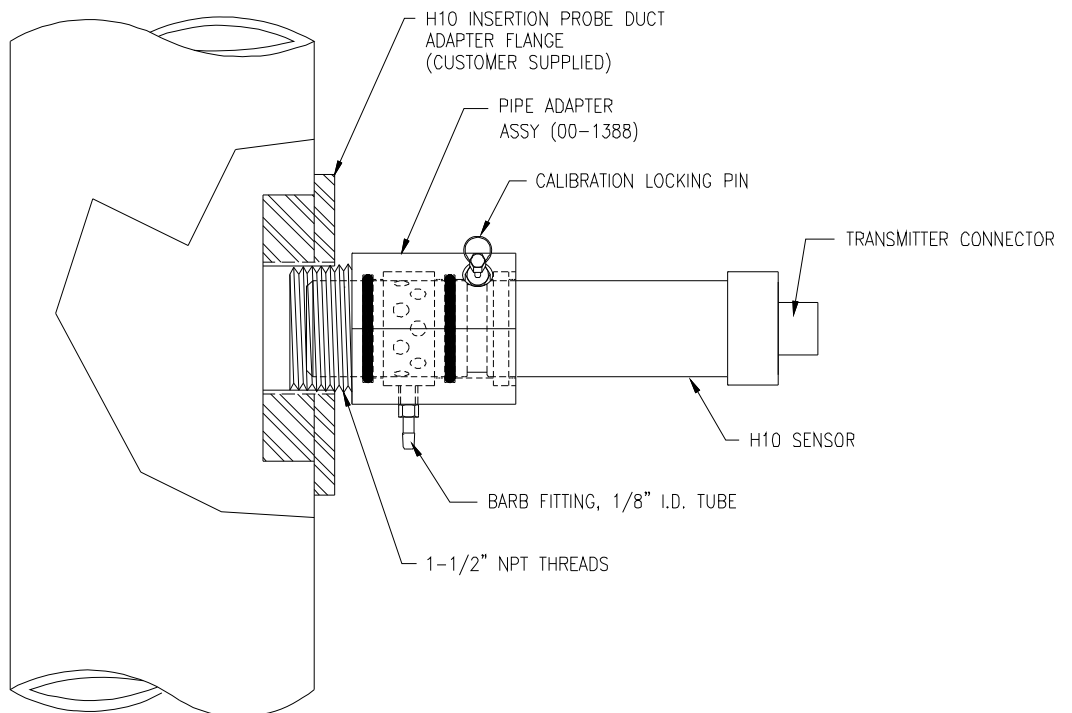

ATI-0664



**INTEGRAL INSERTION PROBE - DIMENSIONS**

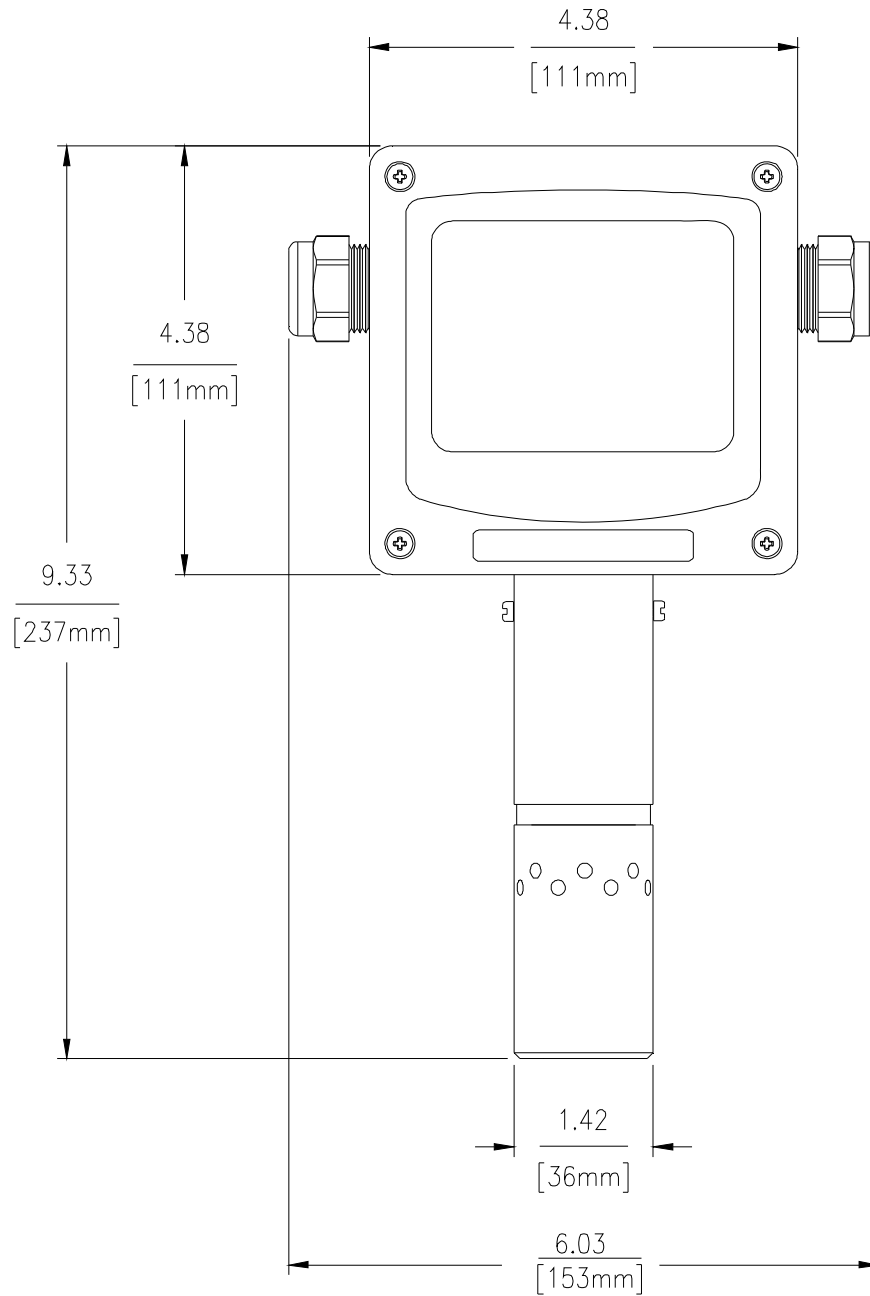

ATI-1131

**INTEGRAL INSERTION PROBE - OPERATING MODE**

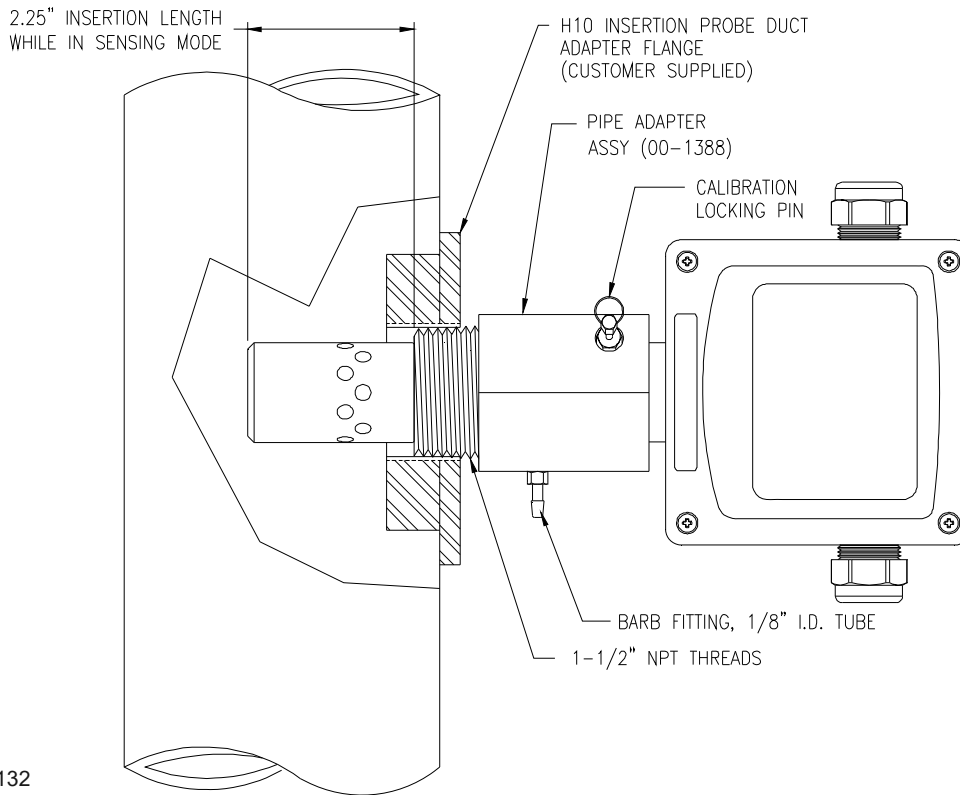

ATI-1132

**INSERTION PROBE - CALIBRATING MODE**

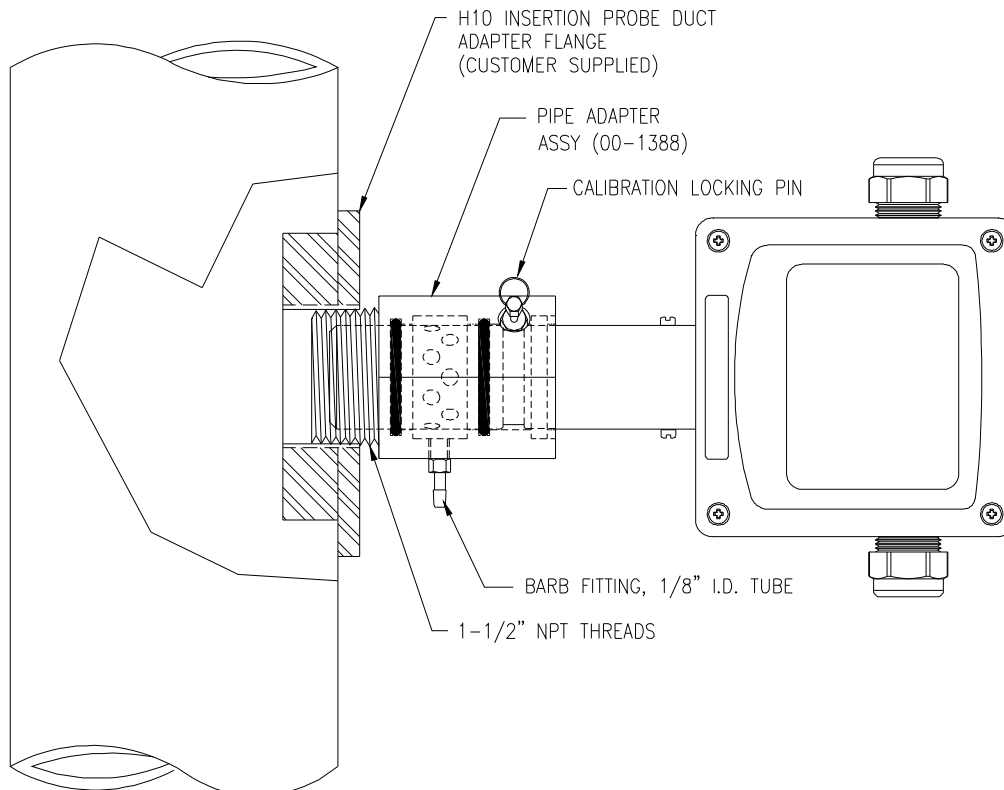

ATI-1133

**INSERTION PROBE - WIRING DIAGRAM**

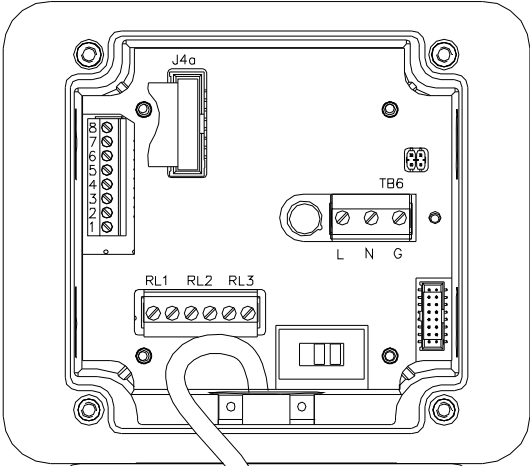

Conductor Colors	
TB3 Pos	Sensor Wires
1	WHITE FROM SHLD
2	BROWN
3	RED & (2) DRAINS
4	BLACK
5	YELLOW
6	GREEN
7	BLUE
8	VIOLET
9	GRAY
10	WHITE
11	BLK/WHT
12	BLU/WHT
13	N/C
14	NC

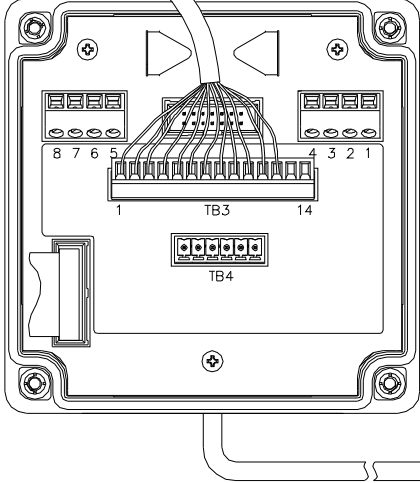

SENSOR CABLE ASSY  
(03-0414)

H10 INSERTION SENSOR  
(00-1649)



ATI-0876

**6 FT. SENSOR CABLE - WIRING DIAGRAM**

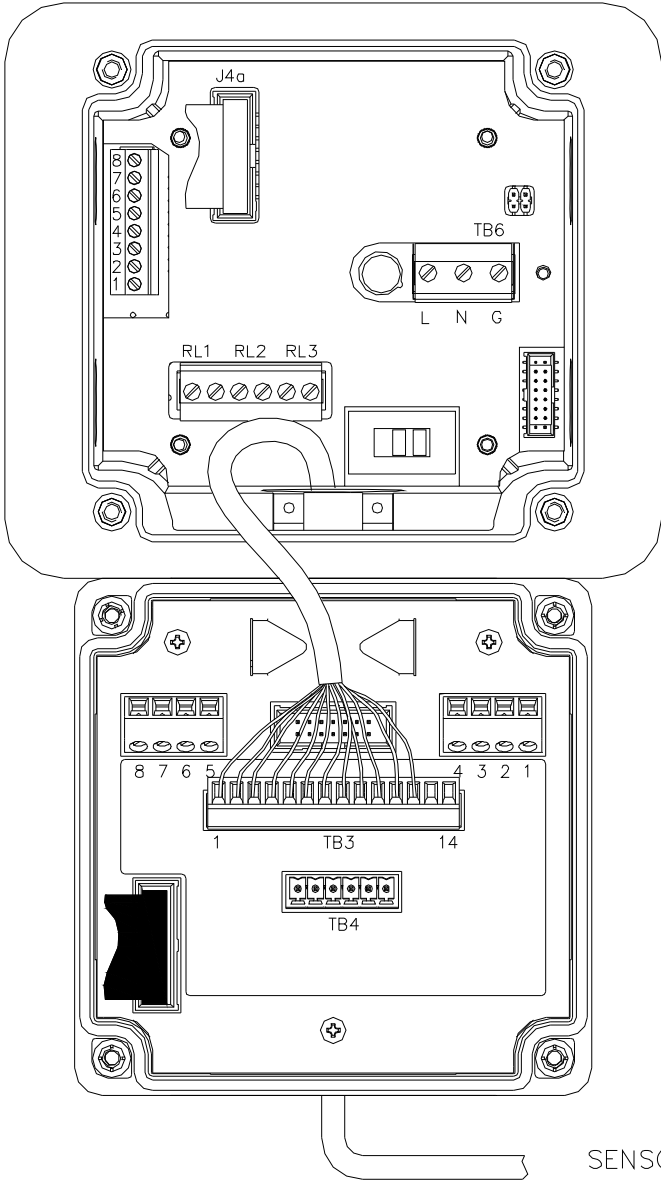

Conductor Colors	
TB3 Pos	Sensor Wires
1	WHITE
2	YELLOW
3	BLUE & (2) DRAINS
4	PURPLE
5	GRAY
6	N/C
7	BLACK
8	BROWN
9	RED
10	BLK w/ WHITE
11	N/C
12	GREEN
13	N/C
14	NC

SENSOR HOUSING w/ 6 FT CABLE

ATI-0890