



## O & M Manual



### Model Q45C4 Portable 4E Conductivity Monitor

#### Home Office

Analytical Technology, Inc.  
6 Iron Bridge Drive  
Collegeville, PA 19426  
Phone: 800-959-0299  
610-917-0991  
Fax: 610-917-0992  
Email: [sales@analyticaltechnology.com](mailto:sales@analyticaltechnology.com)

#### European Office

ATI (UK) Limited  
Unit 1 & 2 Gatehead Business Park  
Delph New Road, Delph  
Saddleworth OL3 5DE  
Phone: +44 (0)1457-873-318  
Fax: + 44 (0)1457-874-468  
Email: [sales@atiuk.com](mailto:sales@atiuk.com)

# Table of Contents

---

<b>PART 1 - INTRODUCTION</b> .....	<b>4</b>
1.1 General.....	4
1.2 Features.....	4
1.3 Q45C4 System Specifications .....	5
1.4 Q45C4 Performance Specifications .....	6
<b>PART 2 – INSTRUMENT HANDLE/MOUNTING</b> .....	<b>7</b>
2.1 General.....	7
2.2 Portable Handle .....	7
<b>PART 3 – ELECTRICAL INSTALLATION</b> .....	<b>8</b>
3.1 General.....	8
3.2 Direct Sensor Connection .....	8
3.3 Sensor Connection .....	9
<b>PART 4 – CONFIGURATION</b> .....	<b>10</b>
4.1 General.....	10
4.2 Battery / Power Circuit Board .....	10
4.3 Battery Power Circuit Board.....	12
4.3 Voltage Outputs .....	12
4.5 User Interface.....	13
4.51 Keys .....	14
4.52 Display.....	14
.....	14
4.6 Software.....	15
4.61 Software Navigation .....	15
4.62 Measure Menu [MEASURE].....	18
4.23 Calibration Menu [CAL] .....	18
4.24 Configuration Menu [CONFIG] .....	19
4.26 Diagnostics Menu [DIAG].....	21
<b>PART 5 – CALIBRATION</b> .....	<b>24</b>
5.1 Overview and Methods.....	24
5.11 1-Point Calibration Explained .....	24
5.12 Zero Cal Calibration Explained .....	24
5.2 Performing a Sensor Zero Calibration .....	24
5.3 Performing a 1-Point Calibration.....	25
5.4 Temperature Calibration .....	26
<b>PART 6 – SYSTEM MAINTENANCE</b> .....	<b>28</b>
6.1 System Checks.....	28
6.2 Instrument Checks .....	28
6.3 Cleaning the Sensor .....	28
6.4 Troubleshooting .....	29
6.5 Display Messages .....	30
<b>SPARE PARTS</b> .....	<b>32</b>

# Table of Contents

---

<i>FIGURE 1 - PORTABLE HANDLE - VIEWS .....</i>	<i>7</i>
<i>FIGURE 2 - SENSOR CABLE PREPARATION .....</i>	<i>8</i>
<i>FIGURE 3 - SENSOR CONNECTION .....</i>	<i>9</i>
<i>FIGURE 4 - BATTERY BOARD CONNECTIONS.....</i>	<i>11</i>
<i>FIGURE 5 - USER INTERFACE.....</i>	<i>13</i>
<i>FIGURE 6 - SOFTWARE MAP .....</i>	<i>17</i>
<i>FIGURE 7 - NAACL REFERENCE SOLUTION FOR CALIBRATION.....</i>	<i>25</i>

# Part 1 - Introduction

---

## 1.1 General

The Model Q45C4 Portable Conductivity monitor/analyzer provides an extremely versatile measurement system for monitoring and control of conductivity over the range of 10  $\mu\text{S}/\text{cm}$  to 2.000 Siemens/cm.

The system operates on two AA and will run continuously for approximately 240 hours.



**Warning: If unit is to be stored for more than 6 months REMOVE the batteries from the holder to avoid potential damage from battery leakage**

The Q45C4 portable displays conductivity and sensor temperature. The instrument is used with the high performance Q25C4 sensors.

## 1.2 Features

- Standard Q45C4 electronic transmitters are designed to be a fully isolated, battery operated instrument. The monitor can be quickly converted to either a loop power transmitter or line powered analyzer.
- Two 10-bit, isolated, 0-2.5 VDC analog outputs may be configured to track conductivity, TDS, and/or temperature. Both analog outputs can be individually programmed to fail to specific values.
- Large, high contrast, custom Super-Twist display provides excellent readability. The secondary line of display utilizes 5x7 dot matrix characters for clear message display. Two of four measured parameters may be on the display simultaneously. An LED backlight can be turned on if necessary for use in very low light conditions.
- 4-Electrode measurement system. Two of the electrodes are used to establish the sensor drive potential, while the other two sense the flow of current between the drive electrodes and maintain proper drive potential. Sensor diagnostics monitor electrode coating/fouling, sensor leaks, and RTD condition. Diagnostic messages provide a clear description of any problem with no confusing error codes to look up. Messages are also included for diagnosing calibration problems.
- Quick and easy one-point calibration method and sensor zero-cal. To provide high accuracy, all calibration methods include stability monitors that check temperature and main parameter stability before accepting data.
- High accuracy Pt1000 temperature input. Temperature element can be user calibrated.
- Security lock feature to prevent unauthorized tampering with transmitter settings. All settings can be viewed while locked, but they cannot be changed.
- PEEK electrode insulator, custom rear PEEK sealing nut and triple o-ring rear seal (Viton and EPR) allow complete submersion of the sensor.
- Custom double-shielded cross-linked cable with PE jacket for excellent chemical resistance.

### 1.3 Q45C4 System Specifications

<b>Enclosure</b>	NEMA 4X, polycarbonate, stainless steel hardware, weatherproof and corrosion resistant, HWD: 4.4" (112 mm) x 4.4" (112 mm) x 3.5" (89 mm)
<b>Mounting Options</b>	Hand held w/Nylon Carrying Strap
<b>Weight</b>	DC transmitter configuration: 1 lb. (0.45 kg)
<b>Display</b>	0.75" (19.1 mm) high 4-digit main display with sign 12-digit secondary display, 0.3" (7.6 mm) 5x7 dot matrix. Integral LED back-light for visibility in the dark.
<b>Keypad</b>	4-key membrane type with tactile feedback, polycarbonate with UV coating.
<b>Ambient Temperature</b>	Service, -20 to 60 °C (-4 to 140 °F) Storage, -30 to 70 °C (-22 to 158 °F)
<b>Ambient Humidity</b>	0 to 95%, indoor/outdoor use, non-condensing to rated ambient temperature range
<b>Electrical Certification</b>	Ordinary Location, cCSAus (CSA and UL standards - both approved by CSA), pollution degree 2, installation category 2
<b>EMI/RFI Influence</b>	Designed to EN 61326-1
<b>Output Isolation</b>	600 V galvanic isolation
<b>Filter</b>	Adjustable 0-9.9 minutes additional damping to 90% step input
<b>Temperature Input</b>	Selectable Pt1000 or Pt100 RTD
<b>Displayed Parameters</b>	Main input, 0.0 µS to 2000 mS TDS Sensor temperature, -10.0 to 110.0 °C (14 to 230°F)
<b>MainParameterRanges</b>	Automatic or manual selection of the following: 0 to 2000 uS 0.0 to 2.000 mS 0.00 to 20.00 mS 0.0 to 200.0 mS 0 to 2000 mS 0.0 to 2.000 S
<b>Power:</b>	Two generic AA batteries, low battery indication at 1.60 VDC. Lithium AA batteries recommended for max performance.
<b>Outputs:</b>	Two 0-2.5 VDC isolated outputs are provided on for connection to data recorders, etc.
<b>Battery Life:</b>	Approximately 240 hours of operational use on a set of batteries (without backlight).

**1.4 Q45C4 Performance Specifications**

**(Common to all variations)**

<b>Accuracy</b>	0.3% of span or better ( $\pm 0.1 \mu\text{S}$ )
<b>Repeatability</b>	0.3% of span or better ( $\pm 0.1 \mu\text{S}$ )
<b>Sensitivity</b>	0.05% of span ( $\pm 0.1 \mu\text{S}$ )
<b>Stability</b>	0.1% of span per 24 hours, non-cumulative
<b>Warm-up Time</b>	7 seconds to rated performance
<b>Supply Voltage Effects</b>	$\pm 0.05\%$ span
<b>Instrument Response Time</b>	12 seconds to 90% of step input at lowest setting
<b>Temperature Drift</b>	Span or zero, 0.03% of span/ $^{\circ}\text{C}$
<b>Max. Sensor-Instrument Distance</b>	60 ft. (18.3 meters)
<b>Sensor Types</b>	Model Q25C4 - 6 wire input



Equipment bearing this marking may not be discarded by traditional methods in the European community after August 12 2005 per EU Directive 2002/96/EC. End users must return old equipment to the manufacturer for proper disposal.

# Part 2 –Instrument Handle/Mounting

## 2.1 General

The Q45C4 Portable Conductivity System comes complete with a specially designed handle that allows the system to be comfortably carried, or quickly strapped to a railing. Although the system is designed to be a portable system, it can be permanently mounted for longer term field use. This is possible due to the very long battery life spans that can be achieved with the system.

## 2.2 Portable Handle

A removable handle is included with each unit that provides not only comfortable transportation of the system, but the integral locking strap allows the system to be quickly mounted to pipes or rails for longer term use in one area.

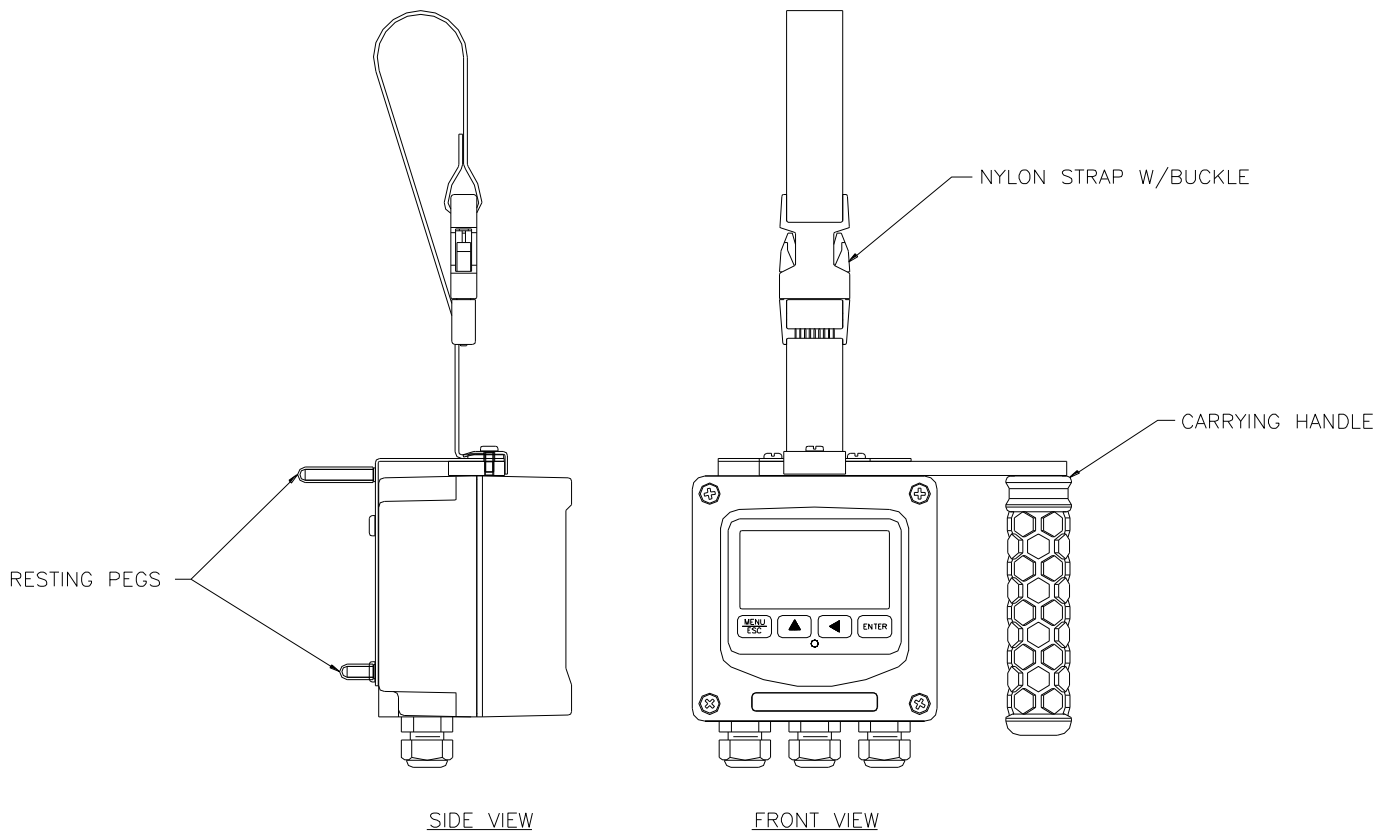

**Figure 1 - Portable Handle - Views**

## Part 3 – Electrical Installation

---

### 3.1 General

The sensor cable can be quickly connected to the Q45 terminal strip by matching the wire colors on the cable to the color designations on the label in the monitor. Keep signal cable away from AC power lines, adjustable frequency drives, motors, or other noisy electrical signal lines.

### 3.2 Direct Sensor Connection

The sensor cable should be routed into the enclosure through the right hand cord grip on the bottom of the enclosure. Make sure the cord-grips are snugly tightened after electrical connections have been made to prevent moisture incursion. When stripping cables, leave adequate length for connections in the transmitter enclosure, as shown below.

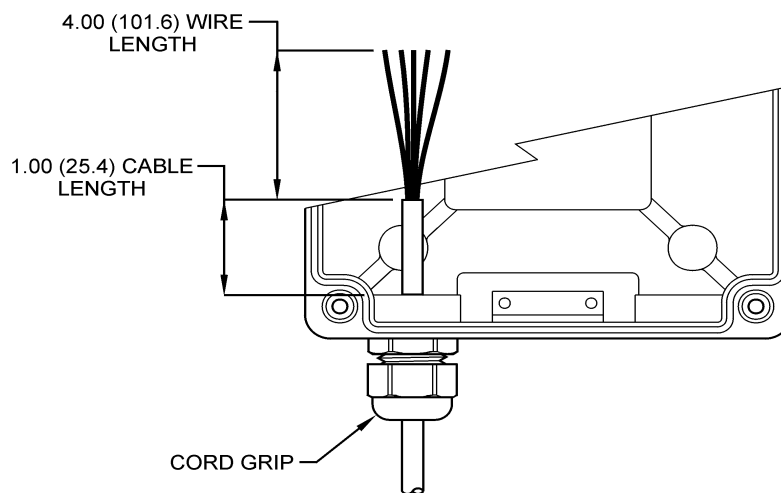

**Figure 2 - Sensor Cable Preparation**



### 3.3 Sensor Connection

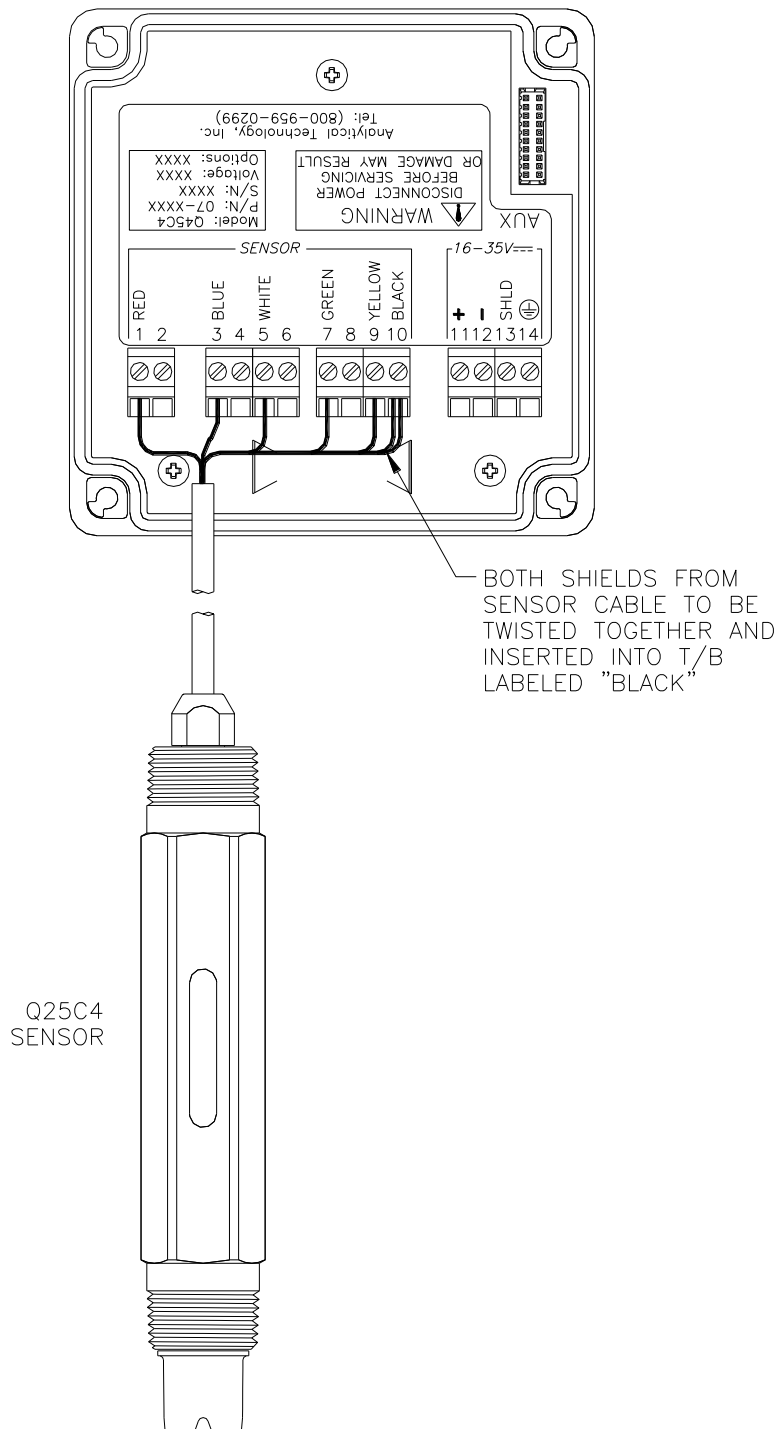

**Figure 3 - Sensor Connection**

## Part 4 – Configuration

---

### 4.1 General

To turn the system ON, simply press and hold the MENU key for approximately 5 seconds and the display will come on. **To turn the unit off, press and hold the ENTER key until the display shuts off (about 3 seconds). Note that the unit must be in the MEASURE menu in order for the 3-second key press to operate.** The instrument will turn off automatically after 30 minutes if no keys are pressed – optimizing battery life. This mode of operation is ideal for portable operation where intermediate readings are being taken. Assuming the instrument is used perhaps an hour per day, this would result in a battery lifespan of about 240 hours. For continuous operation with no automatic shut-off, turn the Auto-OFF feature to OFF in the DIAG menu. This mode is intended for use when the instrument outputs are used for transmitting data. In this mode, the instrument will run continuously until the battery reaches the shut-down level (1.6V). It should be noted that rechargeable AA batteries reduce operational times dramatically, as they typically contain much less energy than standard batteries.

The PWR switch disconnects the AA batteries and is only used to disconnect the battery if the system is not to be used for a long period of time (> 3 months of storage). Otherwise, leave this switch in the ON position. The red dip switch is only for factory use.

The "B" will flash on the display next to the main measurement indication when the instrument requires battery replacement. If the battery is not replaced, eventually the unit may not turn on in the normal operating mode. Once the low battery condition is indicated, the instrument will only stay powered for 10 minutes.

### 4.2 Battery / Power Circuit Board

Q45C4 monitors are powered by internal AA alkaline batteries Figure 5 shows this board assembly with batteries installed.

The battery circuit board contains 3 switch assemblies as shown in Figure 4.

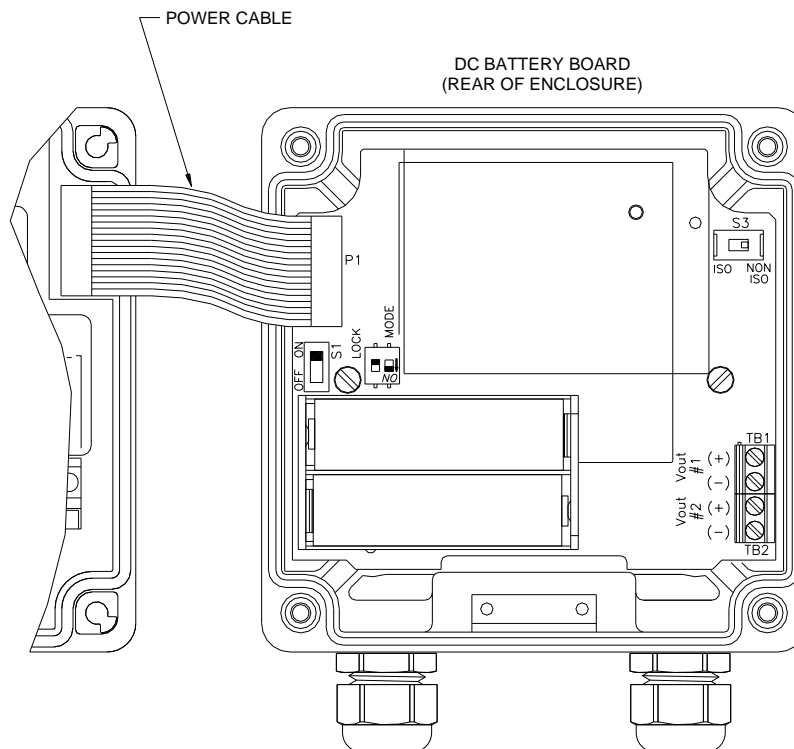

**Figure 4 - Battery Board Connections**

The first (**S1**) is an On/Off slide switch. This switch must be in the ON position for operation. Turn it to OFF if you do not intend to operate the monitor in the next week or two.

The second switch assembly (**S2**) contains two switches, the one on the left marked LOCK and the one on the right marked MODE. The function of these two slide switches are as follow:

- LOCK** This switch is used to define how the monitor will turn on and off. This switch is normally in the OFF position. With the lock switch off, the monitor will be turned on manually using the MENU key on the front of the monitor. With the lock switch in the ON position, the monitor will always be on when there is enough power to run the monitor. The ON position is normally used when operating from an external power supply intended for continuous operation.
- MODE** This switch is used to set the voltage at which monitor will shut off when powered by internal batteries. Alkaline batteries can normally be run down to about 0.8 volts. When using alkaline batteries, the mode switch is in the OFF position (factory default). If rechargeable NiMH batteries are substituted, place the MODE switch in the ON position. Note that rechargeable NiMH batteries have only about 35% of the capacity of an alkalines. However, NiMH batteries can be recharged hundreds of times.

**ISO** The third switch assembly is a single slide switch (**S3**) which defines whether the 0-2.5 VDC signals from the monitor are isolated or non-isolated. Output isolation is not required when outputs are connected to the internal data logger. However, if the outputs are connected to external devices through the external connection cable, putting this switch in the ISO position will protect against possible ground loops. The isolation circuit will slightly increase the power requirement for the monitor, resulting in a bit less battery life.

### 4.3 Battery Power Circuit Board

The Q45 portable instrument is primarily operated by software settings. However, there are also a few hardware details on the battery circuit board to note.

The battery board is a circuit board that sits in the rear of the Q45 enclosure, and connects to the Q45 AUX port through a ribbon cable. The battery board contains the battery clip for the two AA batteries and the output terminal strip for the two 0-2.5 VDC outputs. Along the left side below the ribbon cable is an ON/OFF slide switch. This switch can be used to turn the instrument completely OFF when not intending to use the unit for an extended period.

### 4.3 Voltage Outputs

There are two analog voltage outputs on the battery board with a terminal strip located in the lower right corner. The outputs are 0-2.5 VDC and may be used to send isolated data to remotely located recorders, PLC's, etc. Output #1 is used only for conductivity, and Output #2 can be used for either temperature or an additional conductivity channel.

### 4.5 User Interface

The user interface for the Q45 Series instrument consists of a custom display and a membrane keypad. All functions are accessed from this user interface (no internal jumpers, pots, etc.).

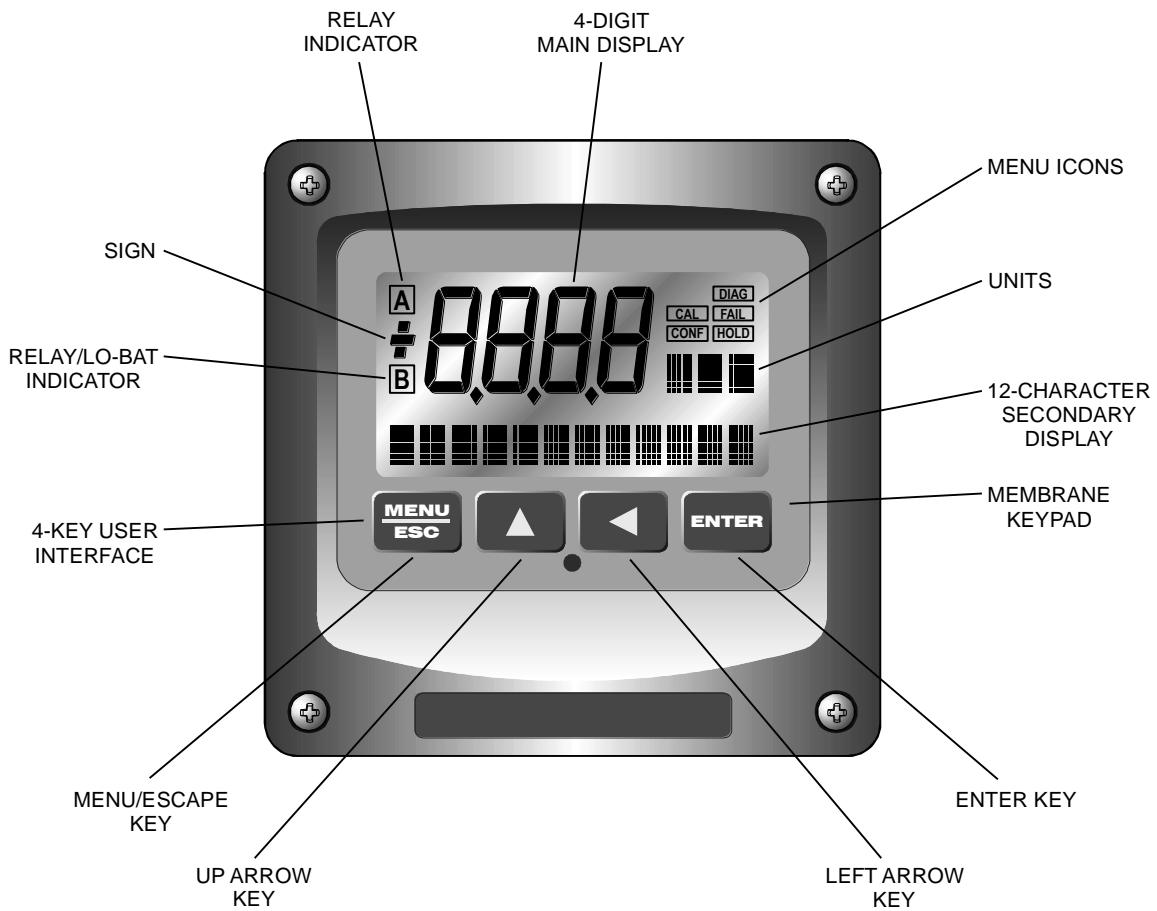

**Figure 5 - User Interface**

## 4.51 Keys

All user configuration occurs through the use of four membrane keys. These keys are used as follows:

<b>MENU/ESC</b>	To scroll through the menu section headers or to escape from anywhere in software. The escape sequence allows the user to back out of any changes in a logical manner. Using the escape key aborts all changes to the current screen and backs the user out one level in the software tree. The manual will refer to this key as either MENU or ESC, depending upon its particular function. In the battery-powered version of the Q45, this is also the ON button.
<b>UP (arrow)</b>	To scroll through individual list or display items and to change number values.
<b>LEFT (arrow)</b>	To move the cursor from right to left during changes to a number value.
<b>ENTER</b>	To select a menu section or list item for change and to store any change.

## 4.52 Display

The large custom display provides clear information for general measurement use and user configuration. There are three main areas of the display: the main parameter display, the secondary message line, and the icon area.

**Main Parameter** During normal operation, the main parameter display indicates the present process input with sign and units. This main display may be configured to display any of the main measurements that the system provides. During configuration, this area displays other useful set-up information to the user.



**Lower Line** During normal operation, the lower line of the display indicates user-selected secondary measurements that the system is making. This also includes calibration data from the last calibration sequence and the transmitter model number and software version. During configuration, the lower line displays menu items and set-up prompts to the user. Finally, the lower line will display error messages when necessary. For a description of all display messages, refer to Section 6.5.



**Icon Area** The icon area contains display icons that assist the user in set-up and indicate important states of system functions. The CAL, CONFIG, and DIAG icons are used to tell the user what branch of the software tree the user is in while scrolling through the menu items. This improves software map navigation dramatically. Upon entry into a menu, the title is displayed (such as CAL), and then the title disappears to make way for the actual menu item. However, the icon stays on.



**HOLD** The HOLD icon indicates that the analog output of the transmitter has been put into output hold. In this case, the output is locked to the last input value measured when the HOLD function was entered. HOLD values are retained even if the unit power is cycled.

**FAIL** The FAIL icon indicates that the system diagnostic function has detected a problem that requires immediate attention. This icon is automatically cleared once the problem has been resolved.

## 4.6 Software

The software of the Q45C4 is organized in an easy to follow menu-based system. All user settings are organized under five menu sections: Measure, Calibration [CAL], Configuration [CONFIG], Control [CONTROL] and Diagnostics [DIAG].

**Note:** The default Measure Menu is display-only and has no menu icon.

### 4.61 Software Navigation

Within the CAL, CONFIG, CONTROL, and DIAG menu sections is a list of selectable items. Once a menu section (such as CONFIG) has been selected with the MENU key, the user can access the item list in this section by pressing either the ENTER key or the UP arrow key. The list items can then be scrolled through using the UP arrow key. Once the last item is reached, the list wraps around and the first list item is shown again. The items in the menu sections are organized such that more frequently used functions are first, while more permanent function settings are later in the list. See Figure 6 for a visual description of the software.

Each list item allows a change to a stored system variable. List items are designed in one of two forms: simple single variable, or multiple variable sequence. In the single variable format, the user can quickly modify one parameter - for example, changing temperature display units from °F to °C. In the multiple variable sequence, variables are changed as the result of some process. For example, the calibration of conductivity generally requires more than one piece of information to be entered. Most of the menu items in the software consist of the single variable format type.

Any data that may be changed will be flashing. This flashing indicates user entry mode and is initiated by pressing the ENTER key. The UP arrow key will increase a flashing digit from 0 to 9. The LEFT arrow key moves the flashing digit from right to left. Once the change has been completed, pressing ENTER again stores the variable and stops the flashing. Pressing ESC aborts the change and also exits user entry mode.

The starting (default) screen is always the Measure Menu. The UP arrow key is used to select the desired display. From anywhere in this section the user can press the MENU key to select one of the four Menu Sections.

The UP arrow icon next to all list items on the display is a reminder to scroll through the list using the UP arrow key.

To select a list item for modification, first select the proper menu with the MENU key. Scroll to the list item with the UP arrow key and then press the ENTER key. This tells the system that the user wishes to perform a change on that item. For single item type screens, once the user presses the ENTER key, part or all of the variable will begin to flash, indicating that the user may modify that variable using the arrow keys. However, if the instrument is locked, the transmitter will display the message **Locked!** and will not enter user entry mode. The instrument must be unlocked by entering the proper code value to allow authorized changes to user entered values. Once the variable has been reset, pressing the ENTER key again causes the change to be stored and the flashing to stop. The message **Accepted!** will be displayed if the change is within pre-defined variable limits. If the user decides not to modify the value after it has already been partially changed, pressing the ESC key aborts the modification and returns the entry to its original stored value.

In a menu item which is a multiple variable sequence type, once the ENTER key is pressed there may be several prompts and sequences that are run to complete the modification. The ESC key can always be used to abort the sequence without changing any stored variables.



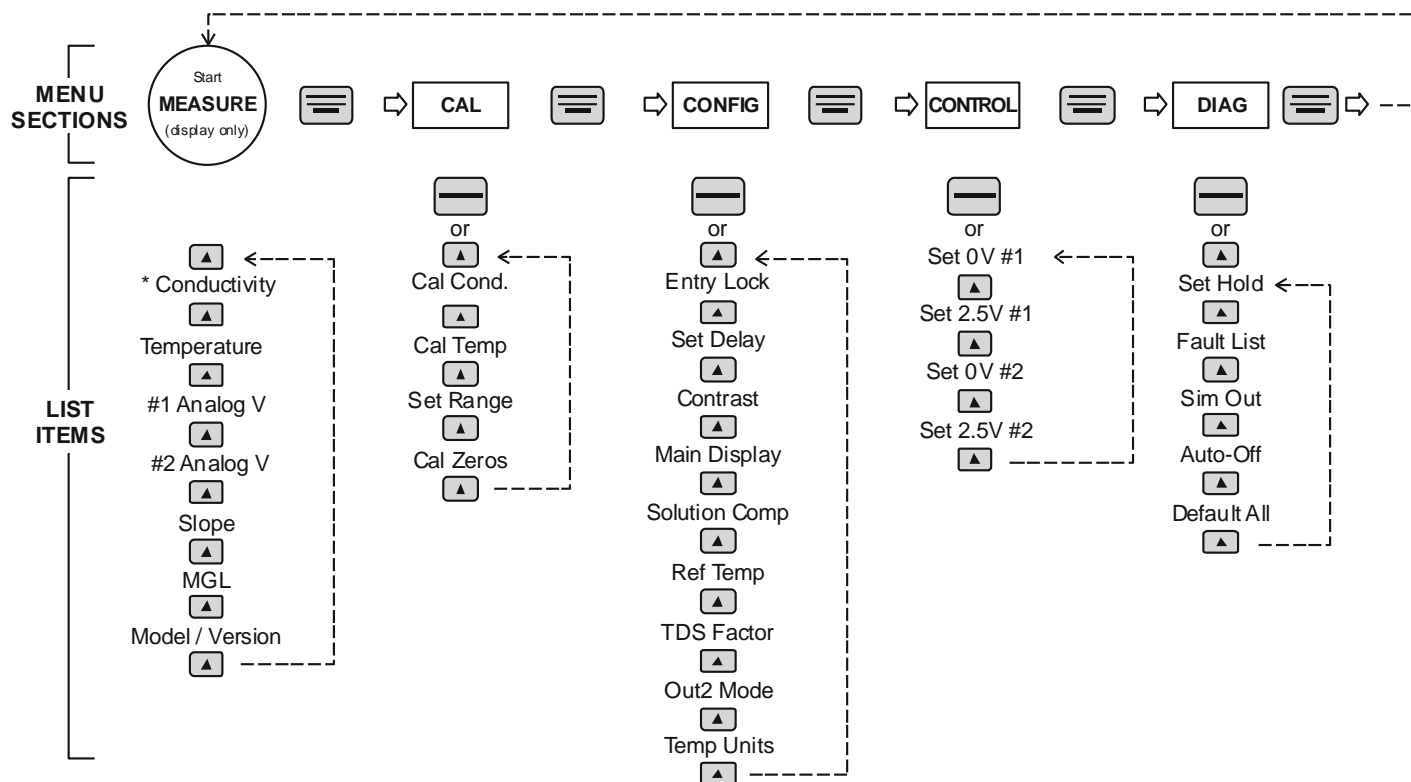

Figure 6 - Software Map

## 4.62 Measure Menu [MEASURE]

The default menu for the system is the display-only menu MEASURE. This menu is a display-only measurement menu, and has no changeable list items. When left alone, the instrument will automatically return to this menu after approximately 30 minutes. While in the default menu, the UP arrow allows the user to scroll through the secondary variables on the lower line of the display. A brief description of the fields in the basic transmitter version is as follows:

### **TRANSMITTER MEAS SCREENS:**

**25.7°C** Temperature display. Can be displayed in °C or °F, depending on user selection. A small “m” on the left side of the screen indicates the transmitter has automatically jumped to a manual 25°C setting due to a failure with the temperature signal input.

**#1 Vout** Instrument Output Signal #1

**#2 Vout** Instrument Output Signal #2

**Slope=100%** Sensor calibration slope (updated after successful calibration has been completed.)

**TDS = 200 mgL** Total Dissolved Solids (TDS). Displays TDS of process.

**Q45C4 v3.00** Transmitter software version number.

**Note:** A display test (all segments ON) can be actuated by pressing and holding the ENTER key while viewing the model/version number on the lower line of the display.

The MEASURE screens are intended to be used as a very quick means of looking up critical values during operation or troubleshooting.

## 4.23 Calibration Menu [CAL]

The calibration menu contains items for frequent calibration of user parameters. There are three items in this list: Cal Cond, Cal Temp, SetRange, and Cal Zeros.

**Cal Cond** The conductivity calibration function allows the user to adjust the transmitter span reading to match reference buffers. See Part 6 - Calibration for more details.

**Cal Temp** The temperature calibration function allows the user to adjust the offset of the temperature response by a small factor of  $\pm 5$  °C. The temperature input is factory calibrated to very high accuracy. However, long cable lengths and junction boxes may degrade the accuracy of the temperature measurement in some extreme situations. Therefore, this feature is provided as an adjustment. See Part 5 - Calibration for more details.

**SetRange** This function sets the user display format for all system menus. For example, setting range to 200.0 mS will display “000.0 mS” units for all settings of relay setpoints, 4-20 points, PID, etc. When autoranging display (Auto) is also selected in the **Main Display** menu in CONFIG, the main measurement display automatically selects the proper display format for measured conductivity – but all setpoints are still set to the **Set Range** value format. The “auto” setting is useful for viewing a very wide range of conductivity values.

An over-range error therefore cannot occur unless the conductivity is above the overall maximum level of 2000 mS. In some applications, users may find the fixed units and decimal point format of the manual ranging mode more preferable. In this mode, the user can select a specific range of operation (e.g., 2000  $\mu$ S) that does not change. In this mode, values greater than the range value selected will cause an over-range alarm. Press ENTER to initiate user entry mode; the entire value will flash. Use the UP arrow key to modify the range value. Press ENTER to store the new value.

**Cal Zeros** This function calibrates all range zero-points to the specific sensor being used. This function is only required to be performed once at initial start-up or when the sensor has been replaced. See Part 5 - Calibration for more details.

#### 4.24 Configuration Menu [CONFIG]

The Configuration Menu contains all of the general user settings:

**Entry Lock** This function allows the user to lock out unauthorized tampering with instrument settings. All settings may be viewed while the instrument is locked, but they cannot be modified. The Entry Lock feature is a toggle-type setting; that is, entering the correct code will lock the transmitter and entering the correct code again will unlock it. The code is preset at a fixed value. Press ENTER to initiate user entry mode and the first digit will flash. Use arrow keys to modify value. **See end of manual for the Q45C4 lock/unlock code.** Press ENTER to toggle lock setting once code is correct. Incorrect codes do not change state of lock condition.

**SetRange** This function allows the user to select either the automatic ranging feature or manual ranging. When autoranging is selected (Auto), the display automatically selects the proper display format for measured conductivity. An over-range error therefore cannot occur unless the conductivity is above the overall maximum level of 2000 mS. In some applications, users may find the fixed units and decimal point format of the manual ranging mode more preferable. In this mode, the user can select a specific range of operation (e.g., 200.0  $\mu$ S) that does not change. In this mode, values greater than the range value selected will cause an over-range alarm. Press ENTER to initiate user entry mode; the entire value will flash. Use the UP arrow key to modify the range value. Press ENTER to store the new value.

**Contrast** This function sets the contrast level for the display. The custom display is designed with a wide temperature range, Super-Twist Nematic (STN) fluid.

The STN display provides the highest possible contrast and widest viewing angle under all conditions. Contrast control of this type of display is generally not necessary, so contrast control is provided as a means for possible adjustment due to aging at extreme ranges. In addition, the display has an automatic temperature compensation network. Press ENTER to initiate user entry mode, and the value will flash. Use arrow keys to modify the value; range is 0 to 8 (0 being lightest). Press ENTER to update and store the new value.

**MainDisplay** This function allows the user to change the measurement in the primary display area. The user may select between Auto, conductivity, sensor temperature, or PID% (if enabled.) Using this function, the user may choose to put temperature in the main display area and conductivity on the secondary, lower line of the display. The "Auto" selection is used to display an autoranging format for displayed conductivity – as opposed to fixed units. It does not affect the format of the settings for relays, 4-20 outputs, etc. Press ENTER to initiate user entry mode, and the entire value will flash. Use the UP arrow key to modify the desired display value. Press ENTER to store the new value.

**Solution Comp** This function sets the correction slope value for the linear/linear temperature compensation method. Linear compensation for most aqueous solutions is typically 2.00 %/°C (25°C reference temperature) for neutral water. This is the factory default and it provides the best compensation for most aqueous solutions. Other typical ranges include:

Acids: 1.0 to 1.6%/°C

Bases: 1.8 to 2.0%/°C

Salts: 2.2 to 3.0%/°C

*Note:* If the temperature units are changed between °C and °F (see Temp Units in this Section), the default setting for this output will change between 2.00 %/°C and 1.11%/°F accordingly.

Other compensation slopes may be found in chemical handbooks for uncommon solutions (such as the CRC). Press ENTER to initiate user entry mode, and the entire value will flash. Use the arrow keys to modify the desired value; entry range is 0.00%/°C to 9.99%/°C. Press ENTER to store the new value

**Ref Temp** The reference temperature function sets the basis point for the linear temperature compensation methods. In most cases this setting should be left at the default of 25.0 °C.

Press ENTER to initiate user entry mode, and the entire value will flash. Use the arrow keys to modify the desired value; range is 0.0°C to 50.0°C. Press ENTER to update and store the new value.

<b>TDS Factor</b>	<p>This function sets the linear relationship of the TDS (total dissolved solids) reading to the conductivity measurement. The actual units for the slope are in mg/L/<math>\mu</math>S. The default value is 00.49 mg/L/<math>\mu</math>S.</p> <p>Press ENTER to initiate user entry mode, and the entire value will flash. Use the arrow keys to modify the desired value; range is 00.00 mg/L/<math>\mu</math>S to 99.99 mg/L/<math>\mu</math>S. Press ENTER to update and store the new value</p>
<b>Out#2 Mode</b>	<p>This function sets analog output #2 for either temperature (default), conductivity, or TDS. Press ENTER to initiate user entry mode, and the entire value will flash. Use the UP arrow key to modify the desired value; selections include 1-C/F for temperature, 2-conductivity for conductivity, or 3- TDS. Press ENTER to store the new value.</p>
<b>Temp Units</b>	<p>This function sets the display units for temperature measurement. Press ENTER to initiate user entry mode, and the entire value will flash. Use the UP arrow key to modify the desired display value. The choices are °F and °C. Press ENTER to store the new value.</p>

#### 4.25 Control Menu[CONTROL]

The Control Menu contains all of the output control user settings:

**Set 0V #1**  
**Set 2.5V #1**  
**Set 0V #2**  
**Set 2.5V #2**

These functions set the output range for each of the two instrument outputs. The value stored for the 0V point may be higher or lower than the value stored for the 2.5V point.

The entry values are limited to values within 2.000 Siemens/cm and must be separated by at least 1% of this range. Use the LEFT arrow key to select the first digit to be modified. Then use the UP and LEFT arrow keys to select the desired numerical value. Press ENTER to store the new value.

Output #1 will always be in units of conductivity, as it is fixed to track conductivity. Output #2 will be in either units of conductivity, mg/L or C/F, depending on whether conductivity, TDS or temperature is set for Out#2 in the CONFIG menu.

#### 4.26 Diagnostics Menu [DIAG]

The diagnostics menu contains all of the user settings that are specific to the system diagnostic functions, as well as functions that aid in troubleshooting application problems.

<b>Set Hold</b>	<p>The Set Hold function locks the current loop output values on the present process value. This function can be used prior to calibration, or when removing the sensor from the process, to hold the output in a known state. Once HOLD is released, the outputs return to their normal state of following the process input. The transfer out of HOLD is bumpless on the both analog outputs - that is, the transfer occurs in a smooth manner</p>
-----------------	------------------------------------------------------------------------------------------------------------------------------------------------------------------------------------------------------------------------------------------------------------------------------------------------------------------------------------------------------------------------------------------------------------------------------------------------------

rather than as an abrupt change. An icon on the display indicates the HOLD state, and the HOLD state is retained even if power is cycled. Press ENTER to initiate user entry mode, and entire value will flash. Use the UP arrow key to modify the desired value, selections are **ON** for engaging the HOLD function, and **OFF** to disengage the function. Press ENTER to store the new value.

**Note:** When the Relay Option Board is installed, the Set Hold function holds BOTH current levels, as well as ALL relay settings.

The Set Hold function can also hold at an output value specified by the user. To customize the hold value, first turn the HOLD function on. Press the ESC key to go to the DIAG Menu and scroll to Sim Output using the UP arrow key. Press ENTER. Follow the instructions under Sim Output (see following page).

### Fault List

The Fault List screen is a read-only screen that allows the user to display the cause of the highest priority failure. The screen indicates the number of faults present in the system and a message detailing the highest priority fault present. Note that some faults can result in multiple displayed failures due to the high number of internal tests occurring. As faults are corrected, they are immediately cleared.

Faults are not stored; therefore, they are immediately removed if power is cycled. If the problem causing the faults still exists, however, faults will be displayed again after power is re-applied and a period of time elapses during which the diagnostic system re-detects them. The exception to this rule is the calibration failure. When a calibration fails, no corrupt data is stored. Therefore, the system continues to function normally on the data that was present before the calibration was attempted.

After 30 minutes or if power to the transmitter is cycled, the failure for calibration will be cleared until calibration is attempted again. If the problem still exists, the calibration failure will re-occur. Press ENTER to initiate view of the highest priority failure. The display will automatically return to normal after a few seconds.

### Sim Out

The Sim Out function allows the user to simulate the conductivity level of the instrument in the user selected display range. The user enters a conductivity value directly onto the screen, and the output responds as if it were actually receiving the signal from the sensor. This allows the user to check the function of attached monitoring equipment during set-up or troubleshooting. Escaping this screen returns the unit to normal operation. Press ENTER to initiate the user entry mode, and the right-most digit of the value will flash. Use arrow keys to modify desired value.

The starting display value will be the last read value of the input. The output will be under control of the SIM screen until the ESC key is pressed.

*Note:* If the HOLD function is engaged before the Sim Output function is engaged, the simulated output will remain the same even when the ESC key is pressed. Disengage the HOLD function to return to normal output.

**NOTE: If the HOLD function is engaged before the Sim Output function is engaged, the simulated output will remain the same even when the ESC key is pressed. Disengage the HOLD function to return to normal output.**

#### **Default All**

The Default All function allows the user to return the instrument back to factory default data for all user settings. It is intended to be used as a last resort troubleshooting procedure. All user settings are returned to the original factory values. Hidden factory calibration data remains unchanged. Press ENTER to initiate user entry mode and the value **NO** will flash. Use the UP arrow key to modify value to **YES** and press ENTER to reload defaults.

# Part 5 – Calibration

---

## 5.1 Overview and Methods

Calibration of the Q45C4 is required to accurately match the sensor characteristics to the monitor/analyzer. Since the output of the conductivity sensor does not degrade over time, it is typically only required that the sensor be calibrated at initial installation and then cleaned periodically to maintain proper system accuracy.

It is important for the user to establish a periodic cleaning and calibration-check schedule for sensor maintenance to maintain high system accuracy.

Since the conductivity of a solution is greatly affected by temperature, proper settings for thermal compensation are critical for accurate operation. Before calibrating the instrument for the very first time, it is important to select the proper operating parameters in the configuration menus for temperature compensation methods. Also at initial installation, a temperature calibration must be performed before conductivity can be calibrated.

When using conductivity calibration standards for a wet calibration, take care not to inadvertently contaminate the reference solution; always thoroughly clean the sensor, rinsing off in tap water, and then finish rinsing in pure or de-ionized water. In addition, note that calibration solutions less than 200  $\mu\text{S}$  or greater than 100 mS can be very unstable. Moving the sensor back and forth between different value conductivity reference solutions can quickly contaminate the solutions and render them inaccurate.

### 5.11 1-Point Calibration Explained

The 1-point calibration method is generally known as the "grab sample" calibration method. In the 1-point calibration method, the sensor may be removed from the application and placed into a reference solution. It may also be left in the measurement process and calibrated by reference. The 1-point calibration adjusts the sensor slope to match the exact calibration point. Readings beyond that point are then extrapolated from the determined slope of the calibration line. Since the sensor slope does not degrade over time, frequent re-calibration is unnecessary. Calibration accuracy can be optimized by calibrating with a reference solution which is close to the values typically measured.

### 5.12 Zero Cal Calibration Explained

The sensor offset must be set for the system only on initial sensor installation, or when the cable length has been altered. The Zero Cal method establishes all of the sensor offset points for the instrument's 6 ranges of operation.

## 5.2 Performing a Sensor Zero Calibration

The sensor offset **MUST** be set for the system on initial sensor installation, or when the cable length has been altered. However, it can easily be adjusted at any time by re-calibrating the sensor in air. The sensor zero-calibration generally has little effect in measurements above about 50 mS, but it can have a significant effect in measurements below about 1 mS. If the sensor zero cal is to be performed, it must be done **BEFORE** the 1-point reference calibration.



To begin the sensor zero cal, verify that the sensor is connected and clean and dry. It should be placed in the air with the electrodes at least 1 foot away from any nearby objects. Holding it is not recommended – place on table or just hang.

## Procedure

1. Remove sensor from process and clean thoroughly. Dry sensor and position on table or hang in air (in air is best.) If on table, let end of sensor hang over edge of table.
2. Scroll to the CAL menu section using the MENU key and press ENTER or the UP arrow key. Scroll to the menu **ZeroCal**.
3. Press the ENTER key. The screen will prompt the user to position the sensor in air.
4. Press the ENTER key. The screen will automatically scroll through all ranges and establish and store the proper zero points.

### 5.3 Performing a 1-Point Calibration

This calibration method is intended to be used as an on-line calibration method or a wet-cal with reference solutions. During calibration, the system will display the current conductivity reading, and the user can manually enter a reference value from a reference solution bottle or a comparative reference instrument.

For wet calibrations, the user may use pre-made calibration references (also available from ATI) or a NaCl solution may be made using pure, dried NaCl crystals and one liter of high purity, de-ionized, CO<sub>2</sub>-free water as mixed in the table shown in Figure 5-1. All table data is at 25°C - therefore, the sensor must be at this temperature to calibrate properly using the table data. If another reference calibration solution is being used, be sure to note temperature of reference solution before calibration. Since the sensor must ideally be at the specified temperature, wet calibrations can be difficult to perform accurately.

NaCl Reference Solution for Calibration (25°C)	
µS/cm	NaCl (gm)
100	0.05
200	0.10
500	0.25
1000	0.50
2000	1.01
3000	1.53
4000	2.06
5000	2.61
8000	4.34
10000	5.56
20000	11.59

**Figure 7 - NaCl Reference Solution for Calibration**

During the 1-point calibration, the system will automatically pick the correct range for the calibration reference if the Q45C4 is in the **AUTO** range (see Section 5.11). If the Q45C4 is in a the normal display mode, the user must be careful to calibrate with a solution that falls into the manual range selected. If the calibration solution is outside the manual range, an error will result.

## Procedure

1. If a zero calibration on the sensor is also to be performed, that must be done **FIRST**. The zero calibration process can have an impact on the result of the 1-point calibration. So if a zero cal is required, do that procedure and return here.
2. Determine whether the calibration will be done on-line or with the sensor removed and placed into a reference solution. If the sensor is removed from the application, rinse and clean. When calibrating a toroid sensor in a beaker of reference solution, there must be plenty of clearance between the sensor and any nearby objects – at least 2 inches. Also, gently stir sensor back and forth to remove any bubbles that may be present in the inner bore.
3. If the sensor has been removed and placed into a solution, allow the sensor to temperature equilibrate with the solution as much as possible. With the sensor coming from an application that differs greatly in temperature, the user may have to wait as much as 20 minutes. If the sensor is on-line, the user may want to set the output HOLD feature prior to calibration to lock out any output fluctuations.
4. Scroll to the CAL menu section using the MENU key and press ENTER or the UP arrow key. Scroll until **Cal Cond** is displayed. Press ENTER.
5. The screen will prompt the user to place the sensor into the reference solution (ideally this has already been done to achieve temperature equilibrium.) Once sensor is ready, press ENTER.
6. The system now begins acquiring data for the calibration value. As data is gathered, the units for conductivity and temperature may flash. Flashing units indicate that this parameter is unstable. The calibration data point acquisition will stop only when the data remains stable for a pre-determined amount of time. This can be overridden by pressing ENTER. If the data remains unstable for 10 minutes, the calibration will fail and the message **CalUnstable** will be displayed.
7. The screen will display the last measured conductivity value and a message will be displayed prompting the user for the reference value. The user must then modify the screen value with the arrow keys and press ENTER. The system then performs the proper checks.
8. If accepted, the screen will display the message **PASS** with the slope value, then it will return to the main measurement display. If the calibration fails, a message indicating the cause of the failure will be displayed and the FAIL icon will be turned on.

## 5.4 Temperature Calibration

The temperature input is factory calibrated for the highest accuracy. Temperature calibration is not recommended; however, it is provided for applications in which very long cable lengths are needed. For example, at 50 feet, readings may be off  $\pm 0.2$  °C.

The temperature calibration sequence is essentially a 1-point offset calibration that allows adjustments of approximately  $\pm 5$  °C.

The sensor temperature may be calibrated on line, or the sensor can be removed from the process and placed into a known solution temperature reference. In any case, it is critical that the sensor be allowed to reach temperature equilibrium with the solution in order to provide the highest accuracy.

When moving the sensor between widely different temperature conditions, it may be necessary to allow the sensor to stabilize as much as one hour before the calibration sequence is initiated. If the sensor is on-line, the user may want to set the output HOLD (see Section 4.26) feature prior to calibration to lock out any output fluctuations.

## Procedure

1. Scroll to the CAL menu section using the MENU key and press ENTER or the UP arrow key.
2. Press the UP arrow key until **Cal Temp** is displayed.
3. Press the ENTER key. The message **Place sensor in solution then press ENTER** will be displayed. Move the sensor into the calibration reference (if it hasn't been moved already) and wait for temperature equilibrium to be achieved. Press ENTER to begin the calibration sequence.
4. The calibration data gathering process will begin. The message **Wait** will flash as data is accumulated and analyzed. The °C or °F symbol may flash periodically if the reading is too unstable.
5. The message **Adjust temp value then press ENTER** will be displayed, and the right-most digit will begin to flash, indicating that the value can be modified. Using the UP and LEFT arrow keys, modify the value to the known ref solution temperature. Adjustments up to  $\pm 5$  °C from the factory calibrated temperature are allowed. Press ENTER.
6. Once completed, the display will indicate **PASS** or **FAIL**. If the unit fails, the temperature adjustment may be out of range, the sensor may not have achieved complete temperature equilibrium, or there may be a problem with the temperature element. In the event of calibration failure, it is recommended to attempt the calibration again immediately

# Part 6 – System Maintenance

---

## 6.1 System Checks

1. If the FAIL icon is flashing on the display, check the Fault List to determine the cause of the failure. To access the Fault List, press the MENU/ESC key until the DIAG menu appears. Then press the UP arrow key until the Fault List appears. Press the ENTER key to access the Fault List, and the highest priority fault message will be displayed. For a list of all messages and possible causes/solutions, refer to Section 6.5.
2. Perform a one-point calibration prior to sensor installation.
3. Check sensor cable color to terminal strip markings.
4. For highly unstable behavior, remove sensor from the process and measure the process solution in a plastic beaker. If the reading now stabilizes, place wire in beaker solution and actual process solution to determine if a ground loop exists.

## 6.2 Instrument Checks

1. Remove sensor completely and connect 1100 Ohms from the yellow to black sensor input leads. Make sure the unit is configured for a Pt1000 thermal element and that the temperature is not in manual locked mode. The temperature reading should display approximately 25 °C and the conductivity reading should display approximately 0.0 uS.
2. With a DMM, measure the DC voltage from the white sensor lead connection to the black sensor lead connection. With the positive DMM lead on the white wire, the meter should read between -4.5 and -5.5 VDC.

## 6.3 Cleaning the Sensor

Keep the sensor as clean as possible for optimum measurement accuracy. Frequency of cleaning depends upon the process solution.

Wipe the measuring end of the sensor with a fine abrasive cloth (i.e. Scotchbrite or equiv.). Then rinse with clean water (distilled or de-ionized if possible). This should remove most contaminate buildup.

If necessary, soak the sensor for several minutes in a mild soap solution. Use a small, extra-soft bristle brush (such as a mushroom brush) to thoroughly clean the electrode surfaces. If surface deposits are not completely removed after performing this step, a dilute acid may be used to dissolve the deposits. Soak for a few minutes, then rinse the sensor thoroughly with clean water (distilled or de-ionized if possible).

*Note:* DO NOT soak the sensor in dilute acid solution for more than 5 minutes.

**WARNING: ACIDS ARE HAZARDOUS.** Always wear eye and skin protection when handling. Follow all Material Safety Data Sheet recommendations. A hazardous chemical reaction can be created when certain acids come in contact with process chemicals. Make this

determination before cleaning with any acid, regardless of concentration. **DO NOT** use Hydrochloric Acid on any stainless steel portion of the sensor.

After cleaning the sensor, check measurement and re-calibrate the sensor.

### 6.4 Troubleshooting

The first step in resolving any measurement problem is to determine whether the trouble lies in the sensor or the transmitter. Since measurement problems can often be traced to foulants coating the electrodes, cleaning the sensor using the method outlined in Section 6.3 should always be the first step in any troubleshooting.

If the sensor cannot be calibrated after cleaning, perform the following test. A multimeter will be needed.

1. Disconnect the sensor from the transmitter or junction box.
2. Using a multimeter, verify continuity between electrodes indicated below and the corresponding wire colors in the cable (red, blue, green and white, only).

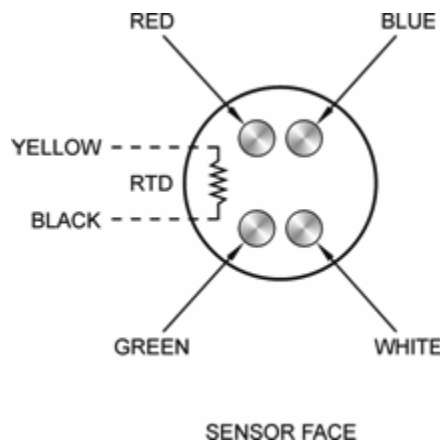

3. Verify that the sensor's temperature element (Pt1000 RTD) is functioning properly by measuring the resistance between the sensor's yellow and black wires. The nominal resistance value at 25 °C is 1097 ohms. Use the following table as a guide to the approximate resistance value:

°C	RTD Ω
20	1078
25	1097
30	1117
35	1136

## 6.5 Display Messages

The Q45 Series instruments provide a number of diagnostic messages that indicate problems during normal operation and calibration. These messages appear as prompts on the secondary line of the display or as items on the Fault List .

The following messages will appear as prompts:

MESSAGE	DESCRIPTION	POSSIBLE CORRECTION
<b>Max is 200</b>	Entry failed, maximum value allowed is 200.	Reduce value to $\leq 200$
<b>Min is 200</b>	Entry failed, minimum value allowed is 200.	Increase value to $\geq 200$
<b>Cal Unstable</b>	Calibration problem, data too unstable to calibrate.	Clean sensor, get fresh cal solutions, allow temperature and conductivity readings to fully stabilize, do not handle sensor or cable during calibration.
<b>Slope HIGH</b>	Sensor slope from calibration is greater than 110%.	Get fresh cal solutions, allow temperature and conductivity readings to fully stabilize, check for correct buffer values
<b>Slope LOW</b>	Sensor slope from calibration is less than 80%.	Clean sensor, get fresh cal solutions, allow temperature and conductivity readings to fully stabilize, check for correct buffer values.
<b>Out of Range</b>	Input value is outside selected range of the specific list item being configured.	Check manual for limits of the function to be configured.
<b>Locked!</b>	Transmitter security setting is locked.	Enter security code to allow modifications to settings.
<b>Unlocked!</b>	Transmitter security has just been unlocked.	Displayed just after security code has been entered.
<b>TC-F25 lock!</b>	The TC selection is in F25 mode, locked at 25 °C	Calibration and TC adjustment cannot be performed while the TC is in F25 mode. To allow access to TC calibrations, change TC mode from F25 (fixed 25) to SENS (sensor).

The following messages will appear as items on the Fault List:

MESSAGE	DESCRIPTION	POSSIBLE CORRECTION
<b>Sensor High</b>	The raw sensor signal is too high.	Check wiring connections to sensor.
<b>Sensor Low</b>	The raw sensor signal is too low.	Check wiring connections to sensor.
<b>Cond too High</b>	The conductivity reading is > 2000 mS.	The conductivity reading is over operating limits.
<b>Temp High</b>	The temperature reading is > 210 °C.	The temperature reading is over operating limits. Check wiring and expected temp level. Perform RTD test as described in sensor manual. Recalibrate sensor temperature element if necessary.
<b>Temp Low</b>	The temperature reading is < -10 °C	The temperature reading is under operating limits. Check wiring and expected temp level. Perform RTD test as described in sensor manual. Recalibrate sensor temperature element if necessary.
<b>TC Error</b>	TC may be open or shorted.	Check sensor wiring and perform RTD test as described in sensor manual.
<b>Clean Sensor</b>	Foulants on sensor have reached the level that they cannot be adjusted out.	Clean the sensor thoroughly.
MESSAGE	DESCRIPTION	POSSIBLE CORRECTION
<b>Cond Cal Fail</b>	Failure of conductivity calibration.	Clean sensor, get fresh cal solutions and redo calibration. If still failure, sensor slope may be less than 50%. Perform sensor tests as described in sensor manual. Replace sensor if still failure.
<b>TC Cal Fail</b>	Failure of temperature calibration.	Clean sensor, check cal solution temperature and repeat sensor temp calibration. TC calibration function only allows adjustments of +/- 6 °C. If still failure, perform sensor tests as described in sensor manual. Replace sensor if still failure. Note that TC offset may also be adjusted using the Cal TC Factor function (See Section 5.6) which involves no calibration reference solutions.
<b>EEprom Fail</b>	Internal nonvolatile memory failure	System failure, consult factory.
<b>Chcksum Fail</b>	Internal software storage error.	System failure, consult factory.
<b>Display Fail</b>	Internal display driver fail.	System failure, consult factory.
<b>Range Cal Fail</b>	Failure of factory temperature calibration.	Consult factory.

## Spare Parts

---

<b><u>Part No.</u></b>	<b><u>Description</u></b>
07-0016	Portable Conductivity Monitor, 3VDC, w/ two 0-2.5 V Outputs
07-0055	4-electrode PEEK sensor
07-0090	4-electrode PEEK sensor w/ connector
09-0046	Conductivity Standard - 84 microSiemens, 500 mL
09-0047	Conductivity Standard - 447 microSiemens, 500 mL
09-0048	Conductivity Standard - 1,500 microSiemens, 500 mL
09-0049	Conductivity Standard – 8,974 microSiemens, 500 mL
09-0050	Conductivity Standard - 80,000 microSiemens, 500 mL

**Lock/Unlock Code: 1453**



# PRODUCT WARRANTY

Analytical Technology, Inc. (Manufacturer) warrants to the Customer that if any part(s) of the Manufacturer's equipment proves to be defective in materials or workmanship within the earlier of 18 months of the date of shipment or 12 months of the date of start-up, such defective parts will be repaired or replaced free of charge. Inspection and repairs to products thought to be defective within the warranty period will be completed at the Manufacturer's facilities in Collegetown, PA. Products on which warranty repairs are required shall be shipped freight prepaid to the Manufacturer. The product(s) will be returned freight prepaid and allowed if it is determined by the manufacturer that the part(s) failed due to defective materials or workmanship.

This warranty does not cover consumable items, batteries, or wear items subject to periodic replacement including lamps and fuses.

Gas sensors carry a 12 months from date of shipment warranty and are subject to inspection for evidence of misuse, abuse, alteration, improper storage, or extended exposure to excessive gas concentrations. Should inspection indicate that sensors have failed due to any of the above, the warranty shall not apply.

The Manufacturer assumes no liability for consequential damages of any kind, and the buyer by acceptance of this equipment will assume all liability for the consequences of its use or misuse by the Customer, his employees, or others. A defect within the meaning of this warranty is any part of any piece of a Manufacturer's product which shall, when such part is capable of being renewed, repaired, or replaced, operate to condemn such piece of equipment.

This warranty is in lieu of all other warranties (including without limiting the generality of the foregoing warranties of merchantability and fitness for a particular purpose), guarantees, obligations or liabilities expressed or implied by the Manufacturer or its representatives and by statute or rule of law.

This warranty is void if the Manufacturer's product(s) has been subject to misuse or abuse, or has not been operated or stored in accordance with instructions, or if the serial number has been removed.

Analytical Technology, Inc. makes no other warranty expressed or implied except as stated above.

## WATER QUALITY MONITORS

Dissolved Oxygen  
Free Chlorine  
Combined Chlorine  
Total Chlorine  
Residual Chlorine Dioxide  
Potassium Permanganate  
Dissolved Ozone  
pH/ORP  
Conductivity  
Hydrogen Peroxide  
Peracetic Acid  
Dissolved Sulfide  
Residual Sulfite  
Fluoride  
Dissolved Ammonia  
Turbidity  
Suspended Solids  
Sludge Blanket Level

**MetriNet** Distribution Monitor

## GAS DETECTION PRODUCTS

NH <sub>3</sub>	Ammonia
CO	Carbon Monoxide
H <sub>2</sub>	Hydrogen
NO	Nitric Oxide
O <sub>2</sub>	Oxygen
CO	Cl <sub>2</sub> Phosgene
Br <sub>2</sub>	Bromine
Cl <sub>2</sub>	Chlorine
ClO <sub>2</sub>	Chlorine Dioxide
F <sub>2</sub>	Fluorine
I <sub>2</sub>	Iodine
H <sub>x</sub>	Acid Gases
C <sub>2</sub> H <sub>4</sub> O	Ethylene Oxide
C <sub>2</sub> H <sub>6</sub> O	Alcohol
O <sub>3</sub>	Ozone
CH <sub>4</sub>	Methane (Combustible Gas)
H <sub>2</sub> O <sub>2</sub>	Hydrogen Peroxide
HCl	Hydrogen Chloride
HCN	Hydrogen Cyanide
HF	Hydrogen Fluoride
H <sub>2</sub> S	Hydrogen Sulfide
NO <sub>2</sub>	Nitrogen Dioxide
NO <sub>x</sub>	Oxides of Nitrogen
SO <sub>2</sub>	Sulfur Dioxide
H <sub>2</sub> Se	Hydrogen Selenide
B <sub>2</sub> H <sub>6</sub>	Diborane
GeH <sub>4</sub>	Germane
AsH <sub>3</sub>	Arsine
PH <sub>3</sub>	Phosphine
SiH <sub>4</sub>	Silane
HCHO	Formaldehyde
C <sub>2</sub> H <sub>4</sub> O <sub>3</sub>	Peracetic Acid
DMA	Dimethylamine